

Setup Guide

Read this manual before attempting to operate the printer. Keep this manual in a handy location for future reference.

Caution • Instructions in this Setup Guide show the PRO-4000 printer. Note that your printer may look different from these illustrations in some cases. However, the basic operations are the same.

Introduction

Before Setting Up the Printer

Before setting up the printer, check the completed image of the printer you purchased and make sure you have enough space to install the printer. It is recommended that you reserve space of the following dimensions to allow you to work around the printer.

Important

- The printer stand and roll unit may be options depending on the model. Care is required because the required space may differ depending on whether or not the options are used.
- The space required in front of the printer differs on how the basket supplied with the printer stand is used. This shows the installation space when used in the position in the illustration.

PRO-2000

Installation space (W x D x H)

• When not using the stand
59.5 x 56.5 x 40.2 inches
(1510 x 1434 x 1020 mm)

• When using the stand
59.5 x 66.3 x 61.5 inches
(1510 x 1684 x 1560 mm)

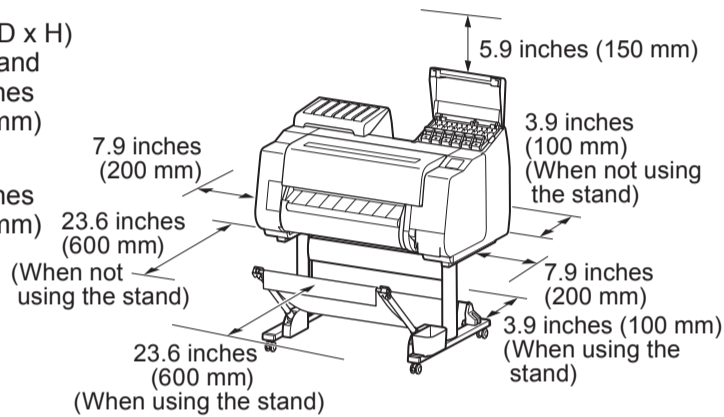

PRO-4000

Installation space (W x D x H)

78.5 x 66.3 x 61.5 inches
(1993 x 1684 x 1560 mm)

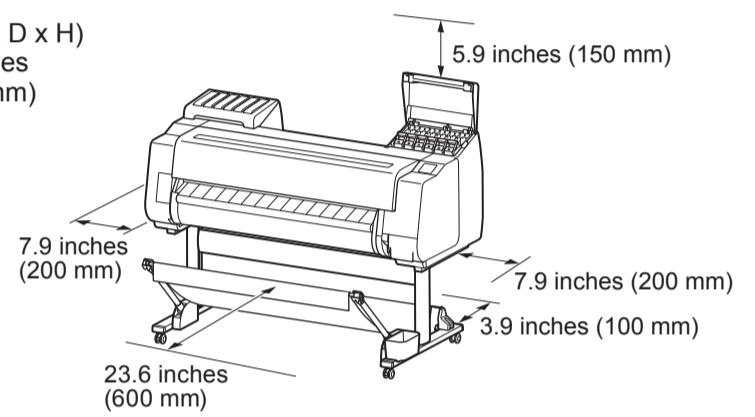

PRO-4000S

Installation space (W x D x H)

78.5 x 66.3 x 61.5 inches
(1993 x 1684 x 1560 mm)

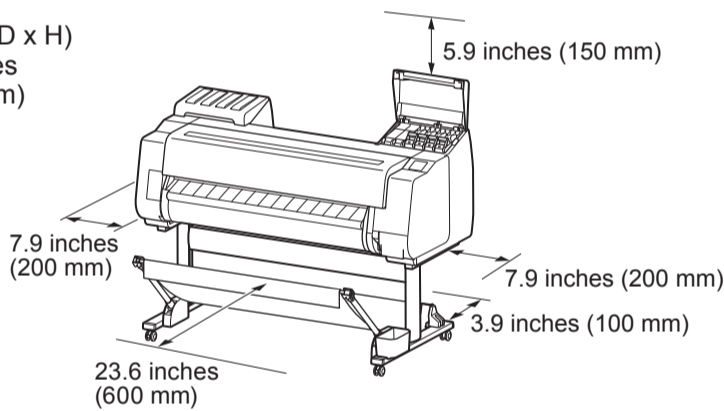

PRO-6000S

Installation space (W x D x H)

94.5 x 66.3 x 61.5 inches
(2399 x 1684 x 1560 mm)

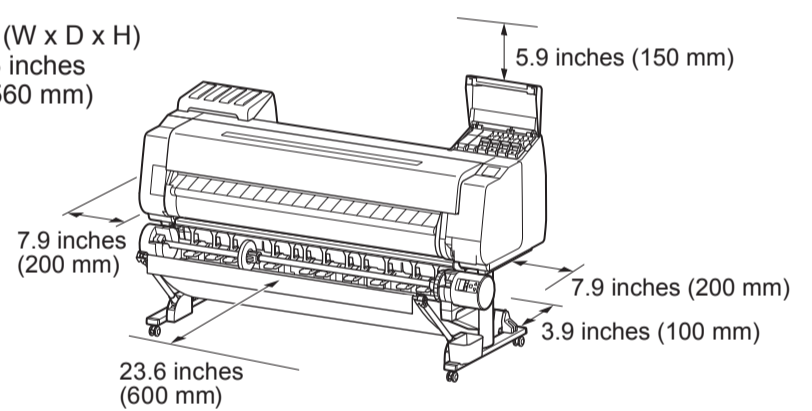

Overview of Setup

Set up the printer using the following procedure.

- * Assemble the Stand (P.3) * Refer to the separate manual
- Install the Printer (P.3)
- * Attach the Roll Unit (P.4) * Refer to the separate manual
- * Attach the Basket (P.4) * Refer to the separate manual
- Turn On the Printer (P.4)
- Install the Ink Tanks (P.6)
- Install the Print Head (P.8)
- Load the Paper (P.9)
- Perform Print Head Adjustment and Select the Connection Method on the PRO-2000 (P.10)
Select the Connection Method and Perform Print Head Adjustment on the PRO-4000, PRO-4000S, and PRO-6000S (P.11)
- Connect to the Printer (P.12)
- Store Accessories in the Pockets (P.13)
- How to Display the Online Manuals (P.14)

If an error message appears during setup or other problems occur, refer to "Responding to Messages" on p.14.

Note

- Some items are included with the printer but not described in this manual. Keep these items in a safe place after setup because they are used in various printing applications.
- For instructions on the included items not described in this manual, refer to the Online Manual. ("How to Display the Online Manuals" on p.14)
- A cable to connect the printer to a computer is not provided with the printer.

• Windows is a trademark or registered trademark of Microsoft Corporation in the U.S. and/or other countries.

RMC (Regulatory Model Code): K10441
RMC (Regulatory Model Code): K10440
RMC (Regulatory Model Code): K10439
RMC (Regulatory Model Code): K10438



Package Contents

• Printer

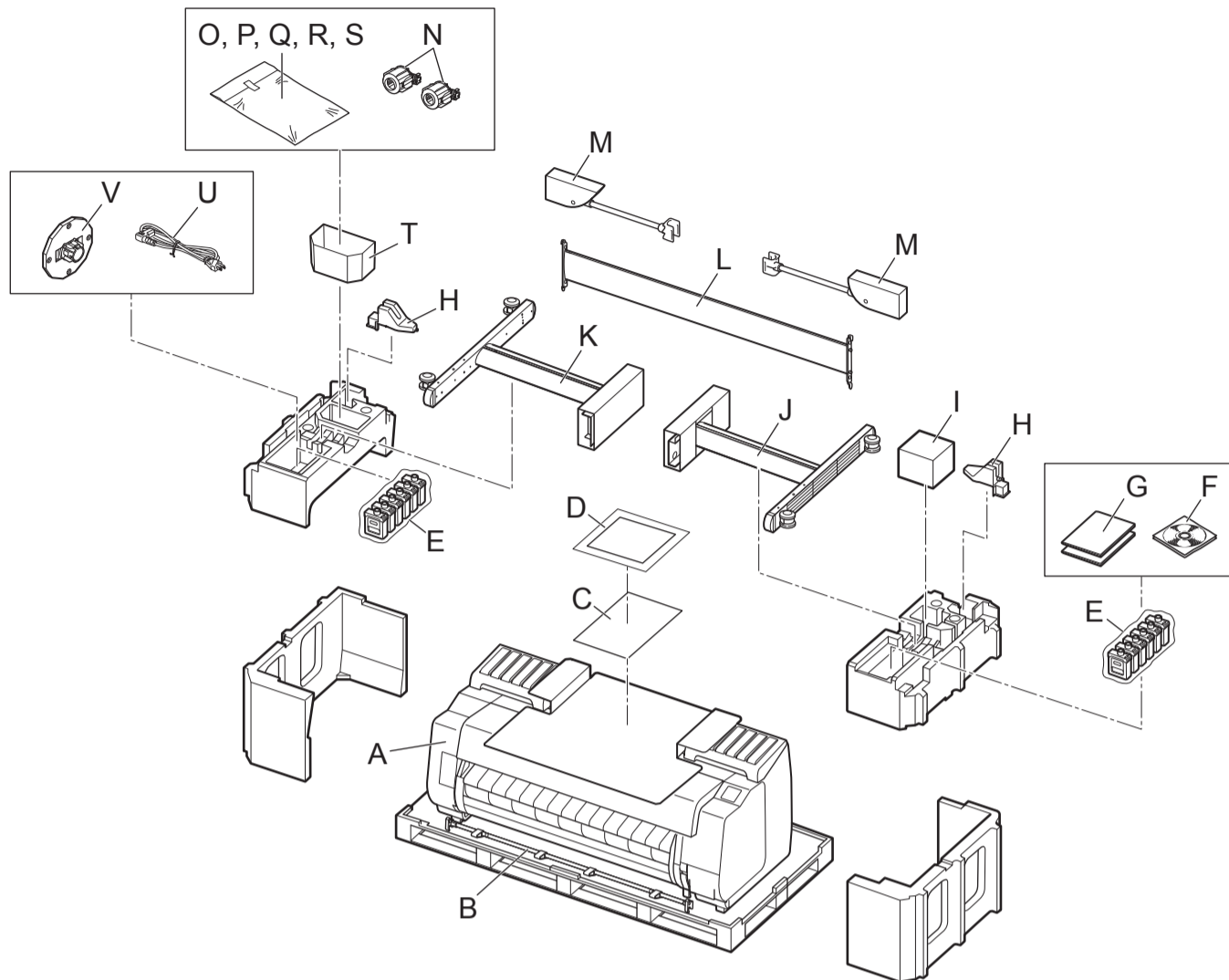

- | | | |
|-----------------------------------|---------------------------------------|---|
| A. Printer | I. Print head | Q. M4 Hex screw for basket arm (x 4) (*1) |
| B. Basket rod / Basket cloth (*1) | J. Stand leg L (*1) | R. M8 Allen wrench (*1) |
| C. Paper for adjustment | K. Stand leg R (*1) | S. M4 Allen wrench (*1) |
| D. Setup Guide (this manual) | L. Stand stay (*1) | T. Accessory pocket (*1) |
| E. Starter ink tanks (x 2) (*2) | M. Basket arm (x 2) (*1) | U. Power cord |
| F. Set of CD-ROMs | N. 3-inch paper core attachment (x 2) | V. Holder stopper (*3) |
| G. Set of printer documentation | O. M4 hex screw (x 9) (*1) | |
| H. Rod holder (x 2) (*1) | P. M8 hex screw (x 4) (*1) | |

*1 Only included with models where the stand is included as standard. Furthermore, it may be packaged in a separate box depending on the region where you purchased the printer.

*2 The number and types of ink tanks differ between models.

For the PRO-2000 and PRO-4000 :

MBK, PBK, C, M, Y, PC, PM, R, CO, B, GY, PGY

For the PRO-4000S and PRO-6000S :

MBK, PBK, C, M, Y, PC, PM, GY

*3 The holder stopper is used when loading roll paper. For details, refer to the Online Manual.

• Roll Unit

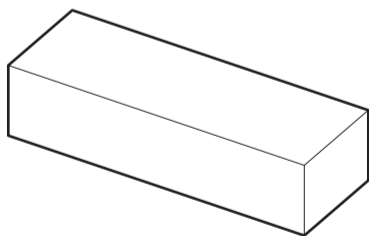

On the PRO-6000S, this is included as standard.
On the PRO-2000, PRO-4000, and PRO-4000S, this is an option.
Refer to the "Roll Unit Setup Guide" for details on the products included in the boxes.

The Manuals Supplied with This Printer

After installing the printer as shown in this Setup Guide, refer to the manuals for instructions on operation and maintenance.

Printed Manuals

Quick Guide

The Quick Guide contains information related to warnings for using this product safely and information related to replacing paper, ink tanks, and the print head.

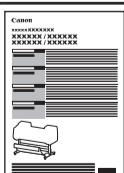

Electronic Manuals

Online Manual

This manual describes advanced usage of the printer such as paper saving tips, how to print a poster and banner with the supplied software and print quality adjusting method, in addition to the basic instructions for printing on roll paper or cut sheet.

To view the electronic manuals, refer to "How to Display the Online Manuals" (p.14).

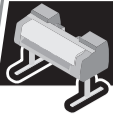

Assemble the Stand

• Models That Use a Stand

Assemble the stand on which you will install the printer.

-> Refer to "Assemble the Stand" to "Prepare to Install the Printer" in the Printer Stand Setup Guide (separate manual).

• Models That Do Not Use a Stand

Proceed to "Install the Printer".



Install the Printer

1 Remove the packaging material.

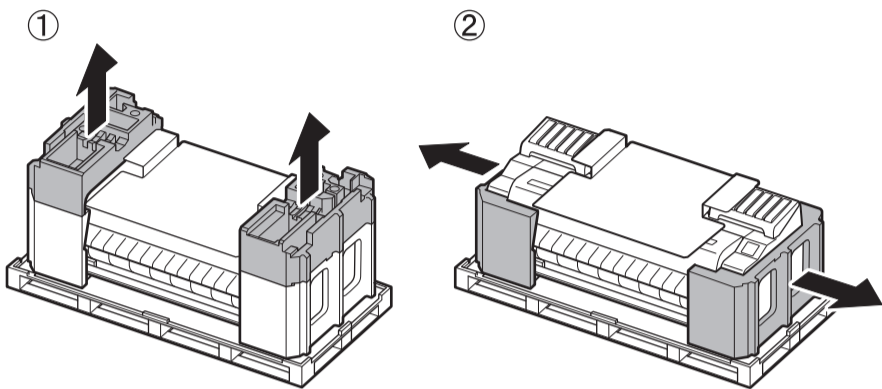

2 Remove all of the tape and other packaging material. Open the top cover (A) and output guide (B), and then remove the tape affixed to the roll holder.

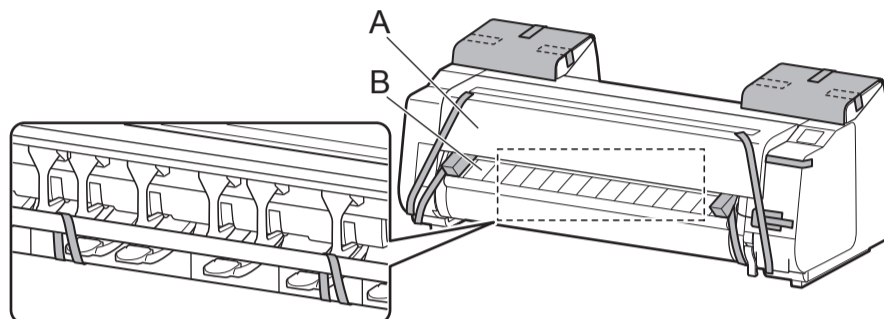

3 With 3 people holding the carrying handles under the printer on both ends, lift the printer.

Caution • The printer alone weighs differently depending on the model. PRO-2000 is approx. 185 lb (84 kg), PRO-4000 is approx. 231 lb (105 kg), PRO-4000S is approx. 227 lb (103 kg), and PRO-6000S is approx. 260 lb (118 kg). Moving the printer requires at least 6 people, 3 on either side. Be careful to avoid back strain and other injuries.

• When moving the printer, firmly grasp the carrying handles (A) under each side. Holding the printer at other positions is dangerous and cause injury and damage if the printer is dropped.

• When setting the printer down temporarily make sure to put the printer on a flat, stable place.

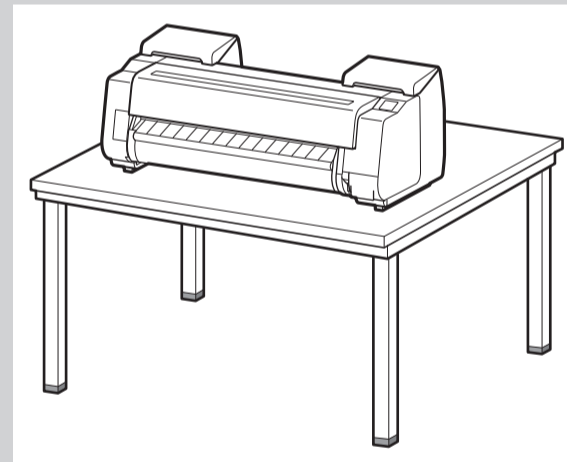
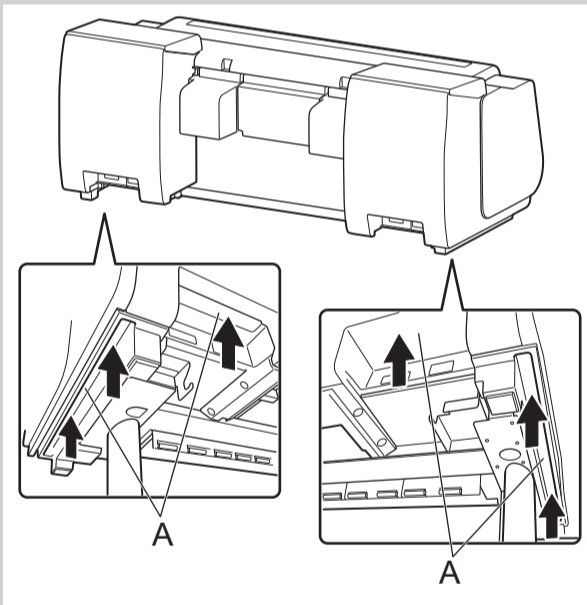
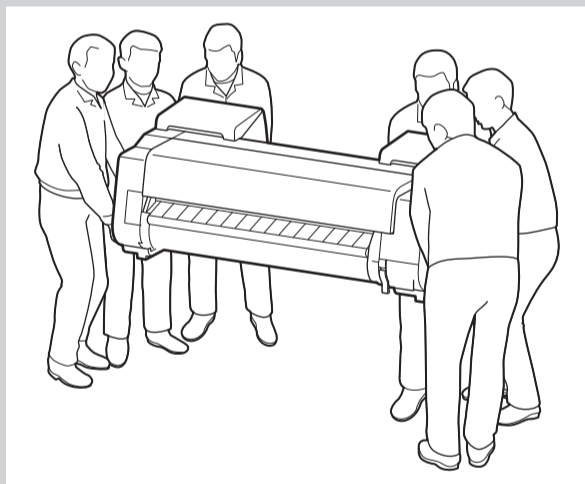

• When standing the printer up, make sure the side with the control panel is up, and place cardboard or other material underneath to prevent scratching. Furthermore, make sure that the weight of the printer is taken by the corner of the printer. If the weight is taken by any other part of the printer, the printer may become damaged.

• When standing up the printer or supporting the printer, hold the metal parts of the printer. If you hold a plastic part, the printer may become damaged.

• The way to set the printer down or to carry with the load only to the center of the printer, may cause damage to the printer.



- 4** Place the printer on the stand such that the protrusion (A) for aligning the position of the printer under the rear side of the printer is aligned with the position of the black marker on the basket rod attached to the supporting plate.

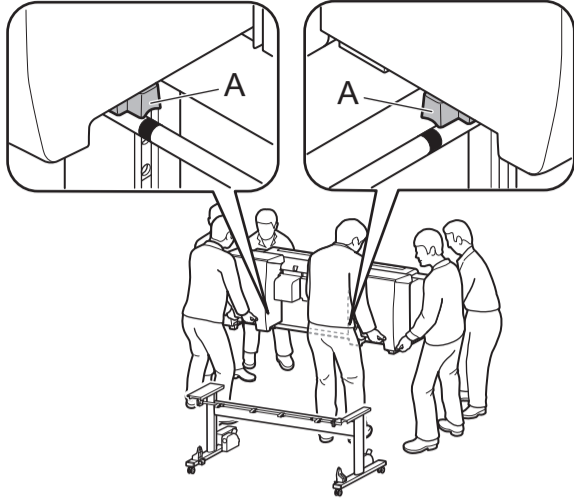

Important • If you are not using a stand, place the printer in the installation location and proceed to "Turn On the Printer".

- 5** Affix the printer to the stand.
 ① Remove the basket rod.
 ② Use an M4 Allen wrench to securely affix by using three M4 hex screws each on the left and right from the bottom of the supporting plate.

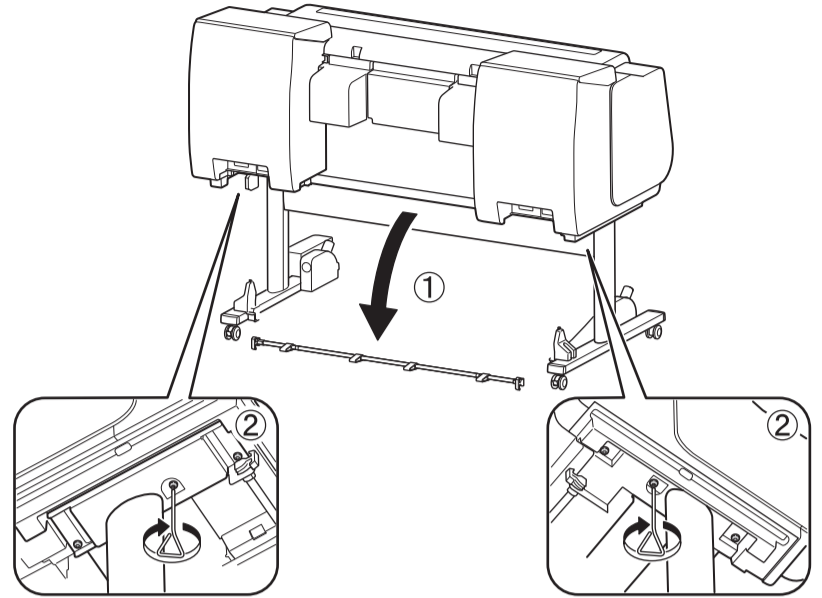

Attach the Roll Unit

- Models That Use the Roll Unit
 Attach the roll unit to the stand.
 -> Refer to the Roll Unit Setup Guide (separate manual).
- Models That Do Not Use the Roll Unit
 Proceed to "Attach the Basket".

Attach the Basket

- Models That Use a Stand
 Attach the basket to the stand.
 -> Refer to "Attach the Basket" in the Printer Stand Setup Guide (separate manual).
- Models That Do Not Use a Stand
 Proceed to "Turn On the Printer".

Turn On the Printer

- 1** Open the top cover.

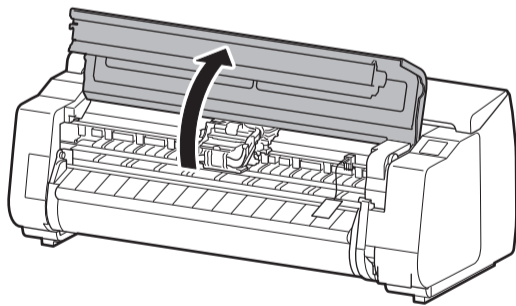

- 2** Pull up and remove the belt stopper (A).

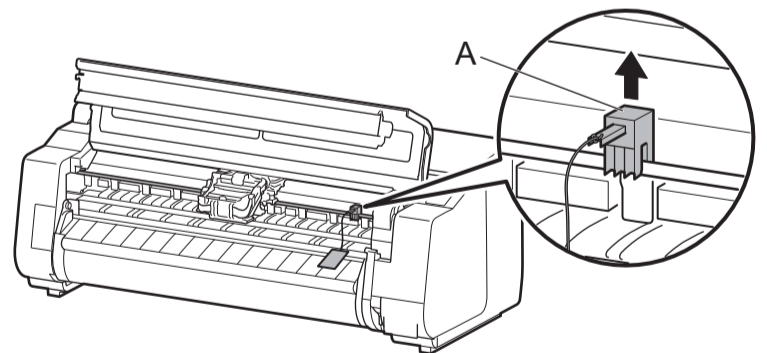

Note

- Keep the belt stopper you removed for future use. You will need them in case you move the printer to another location.
- When you open the top cover, a cleaning brush is stored on the right side. Take it out and use it when cleaning inside the top cover.

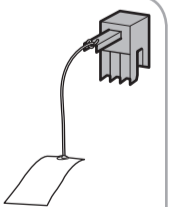

3

Peel off the tape affixed to the carriage, and then pull the protective material (A) towards you and remove it. Remove the protective sheet if there is one attached.

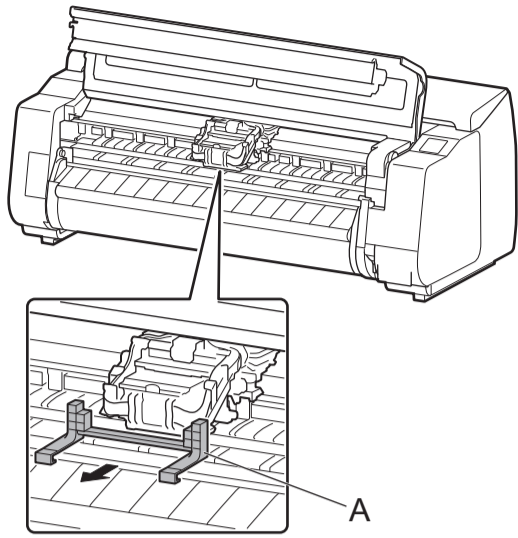

4

Close the top cover.

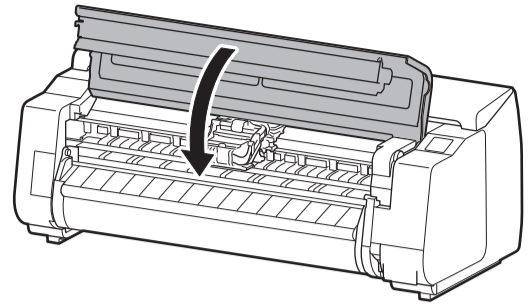

5

Plug the power cord into the power supply connector on the back of the printer.

PRO-2000

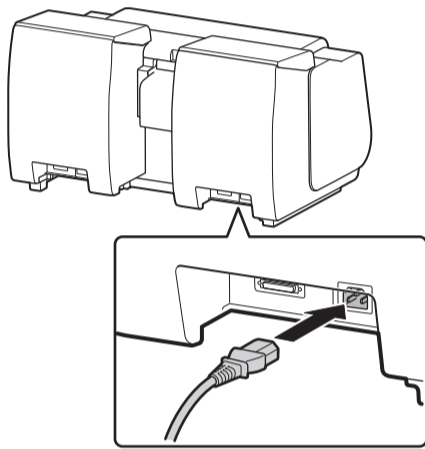

PRO-4000 / PRO-4000S / PRO-6000S

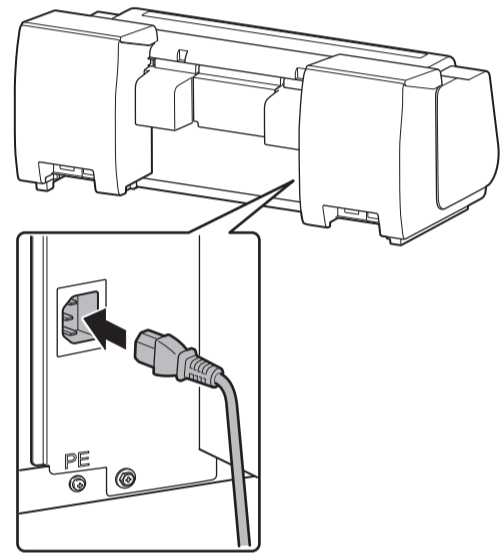

6

Plug the power cord into the outlet.

7

Turn on the printer.

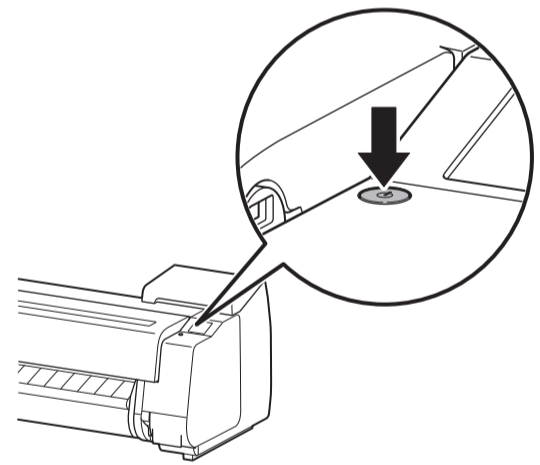

8

When the language selection screen appears on the touch screen, select and tap a language (lightly with your finger, and then move your finger away). Then, if the screen for selecting a time zone appears, select and tap your region.

9

When a message prompting you to start the setup appears on the touch screen, tap **OK**.

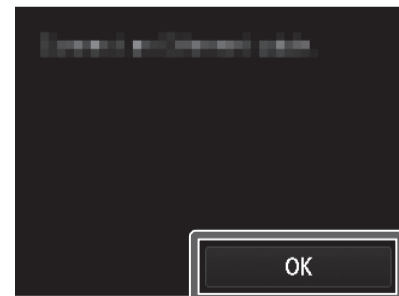
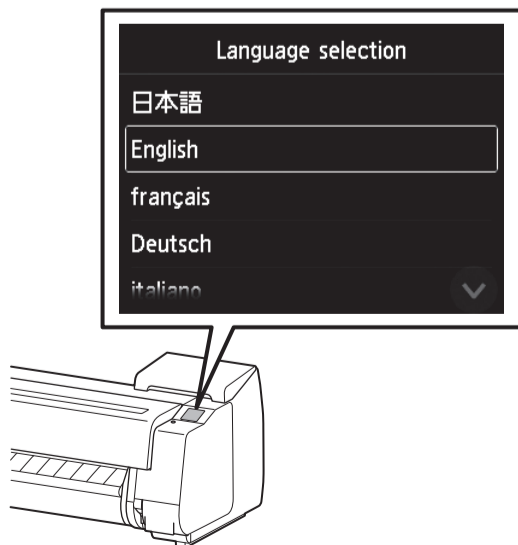



Install the Ink Tanks

Install the ink tanks. The PRO-2000 and PRO-4000 use 12 ink tanks, and the PRO-4000S and PRO-6000S use 8 ink tanks.

1 Instructions on ink tank installation are shown on the screen. Open the ink tank covers as instructed.

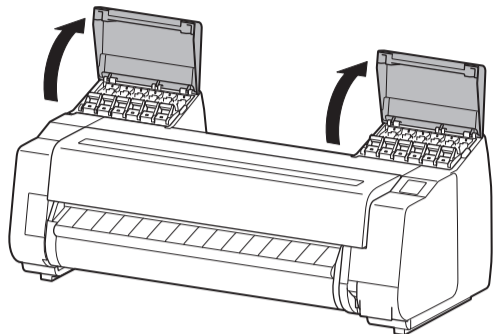

2 Pull out the handle part (A) of the ink tank lock lever for the color of ink to install while pressing the button at position (B).

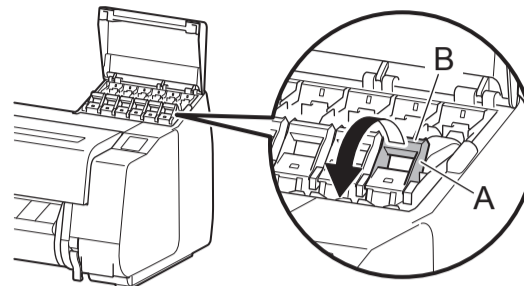

3 Lift up the ink tank lock lever until it stops, and then pull it towards you.

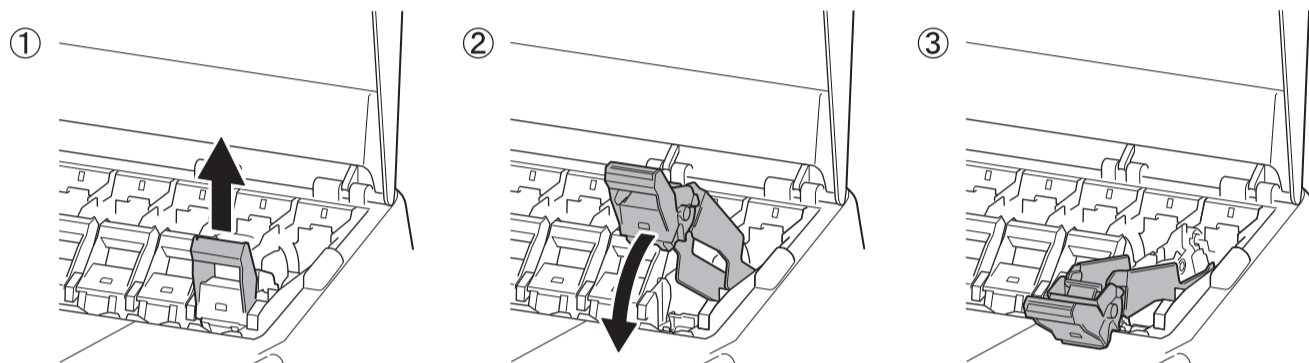

Important • Make sure the ink tank lock lever stays in the locked position.

4 Shake each ink tank gently 7 or 8 times before opening its pouch.

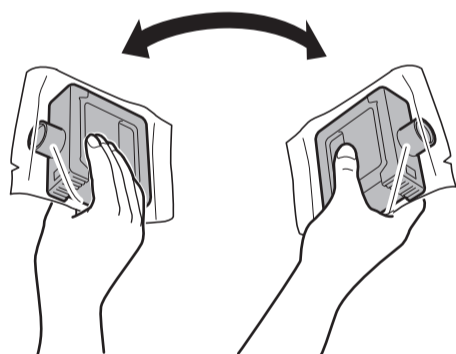

Important • Failure to shake the ink tanks may result in reduced print quality because ink ingredients have settled on the bottom of the tank.

Note • If the ink tank is cold, allow it to adjust to room temperature before attaching it to the printer.

5 Open the pouch and remove the ink tank.

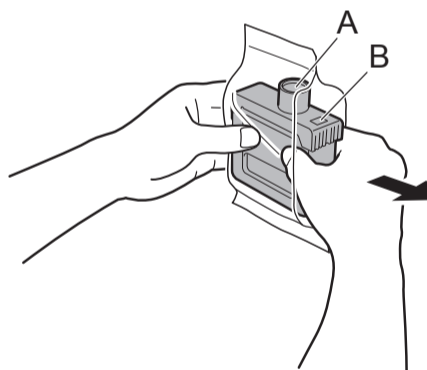

Important • Never touch the ink holes (A) or metal contacts (B). Touching these parts may cause stains, damage the ink tank, and affect print quality.

• Avoid dropping the ink tank after removing it from the pouch. Otherwise, ink may leak and cause stains.

• Do not remove ink tanks to shake them after they have been mounted. Doing so may cause ink to spill.

6 Orient the ink tanks and mount them in the holders with ink holes down and metal contacts on the bottom.



Important • An ink tank cannot be mounted in the holder if it is not oriented correctly for the color.

• Do not try to force an ink tank into the holder if it does not go in normally. Check the color indicated on the label and the ink tank orientation, and then try mounting the tank into the holder again.

7 Lift up the ink tank lock lever once and then push it down.

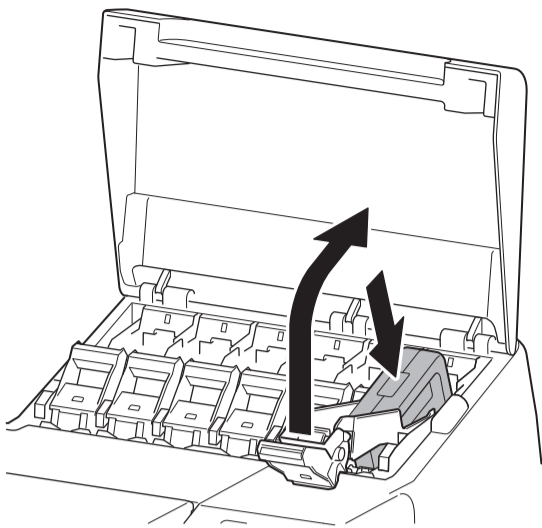

8 Firmly push down the handle part of the ink tank lock lever all the way in.



9 Make sure the ink lamp lights red.

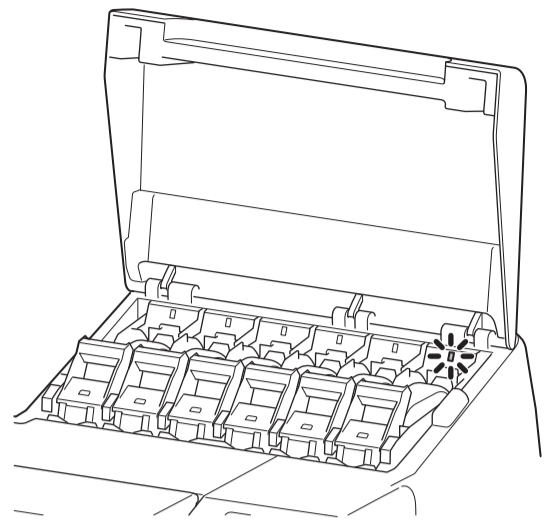

Important

• If the ink lamp does not light, repeat steps 2, 3, 7, and 8.

10 Repeat steps 2 to 9 to install each of the ink tanks. Close the ink tank covers.

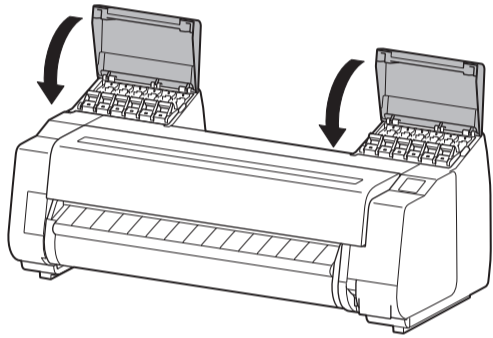



Install the Print Head

1 When the instruction to open the top cover appears on the screen, open the top cover.

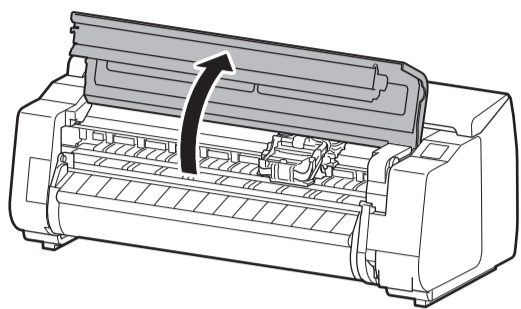

Instructions are now shown on the screen regarding print head installation.

2 Tilt the print head lock lever ① towards you while pressing the button in the middle. Remove the protective sheet if there is one attached.

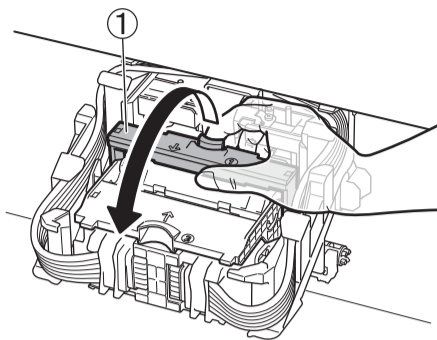

3 Grasp the grip in the center of the print head locking cover ② and open it. Do not touch the contacts (A) on the carriage.

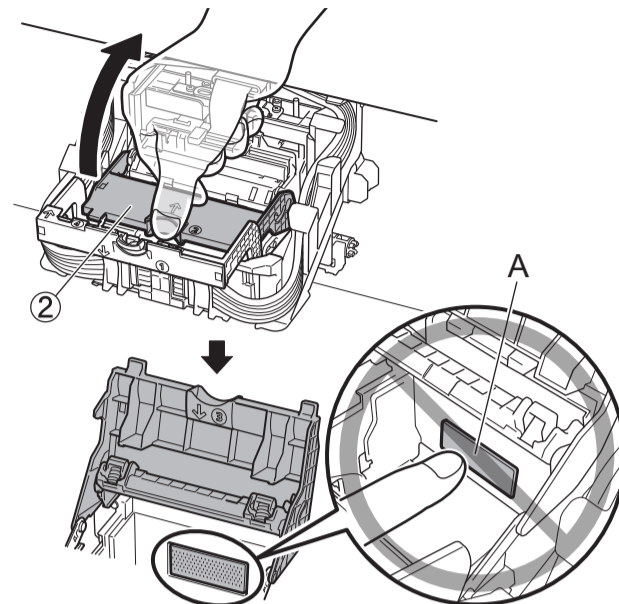

4 ① Remove the print head from the box and bag, and peel off the fixing tape.
② Grasp the blue handle and remove the print head.

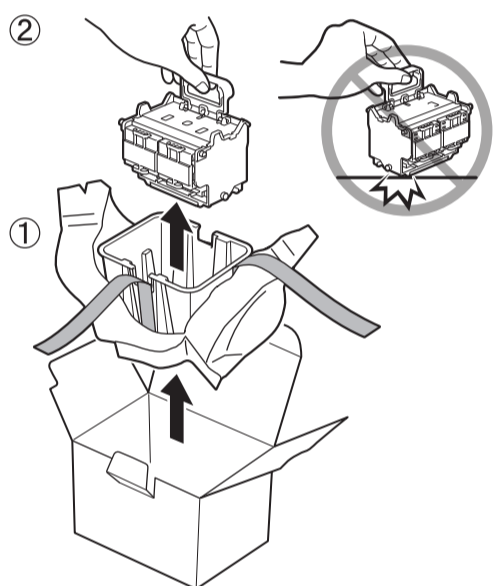

5 Remove the orange protective caps (2 pieces).

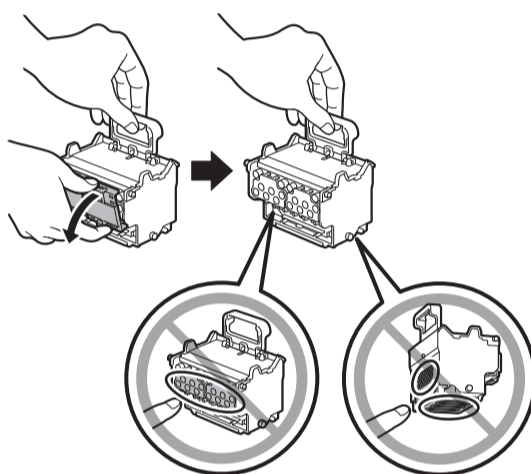

- Do not touch any part other than the handle or put down the unit.
- The print head contains ink, so be careful not to spill it once the protective caps are removed.
- Do not reattach the protective caps after removing them. Dispose of them according to local regulations.

6 Insert the print head into the carriage with the ink holes (A) on the upper side and facing towards you as shown in the figure. Carefully push the print head firmly into the carriage, ensuring that the part covered by the protective caps does not touch the carriage.

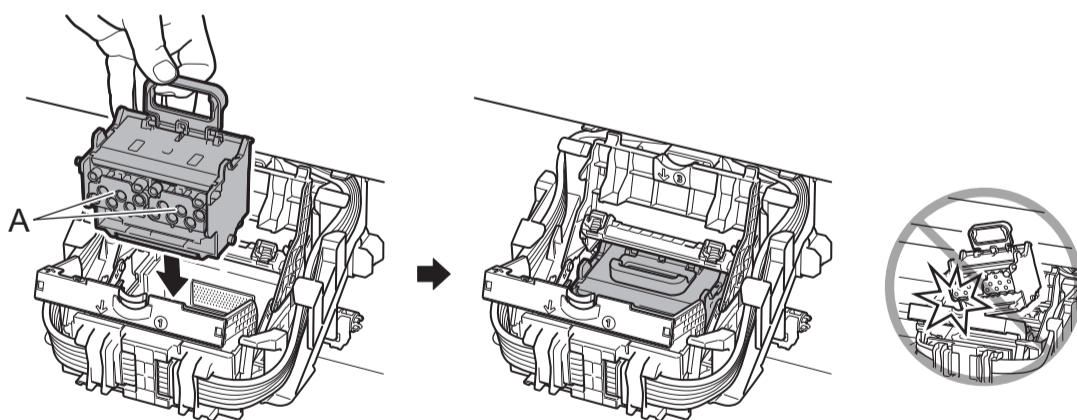

7 Pull the print head locking cover ③ down toward the front to lock the print head in place.

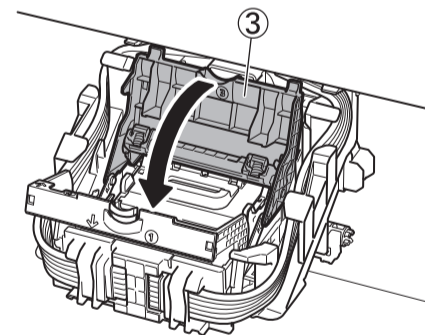

8 Push the print head lock lever ④ all the way in until it makes a click sound.

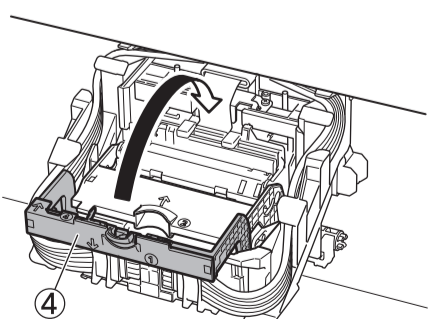

9 Close the top cover.

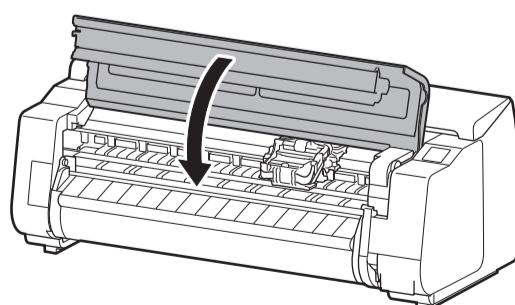

- If the roll unit is installed, the roll unit calibration starts automatically after the print head is attached. If the roll holder is mounted on the roll unit at this time, calibration cannot be executed. Do not mount the roll holder on the roll unit until the setup has finished.



Load the Paper

Load the paper for adjustment.

- 1** ① Tap **OK**.
 ② Tap **Manual**.

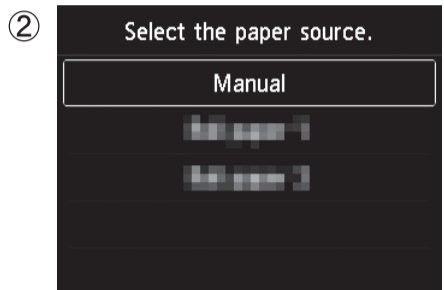
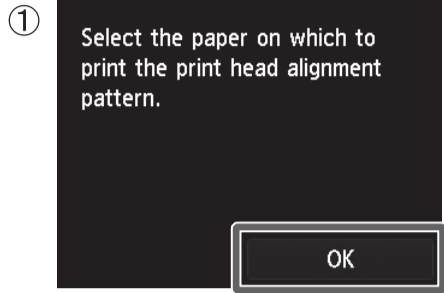

- 2** Open the top cover and lift the release lever.

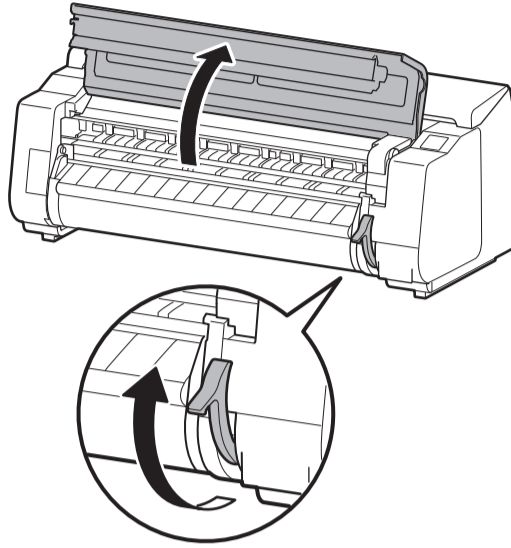

• Do not touch the linear scale (A), carriage shaft (B), or ink tube stabilizer (C). Touching them may cause damage.

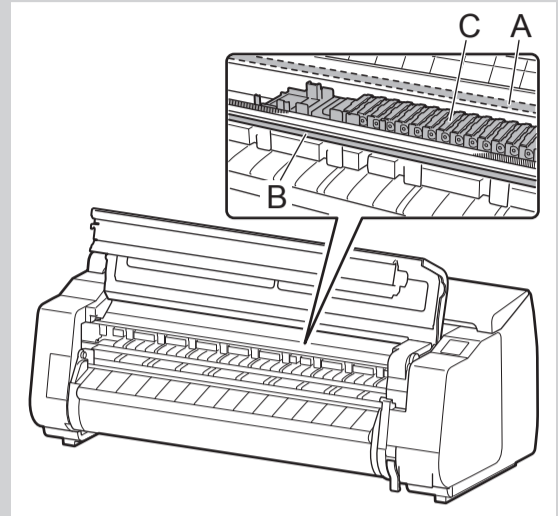

- 3** Insert the paper for adjustment between the platen (A) and paper retainer (B) in portrait orientation with the printed side of the paper facing up.

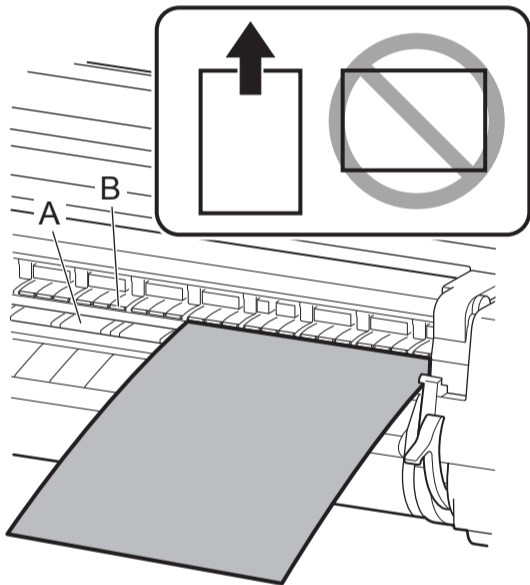

- 4** Load the paper aligned with the paper alignment lines (A) to ensure that the paper is not crooked, and align the leading edge of the paper with the front side of the line (B).

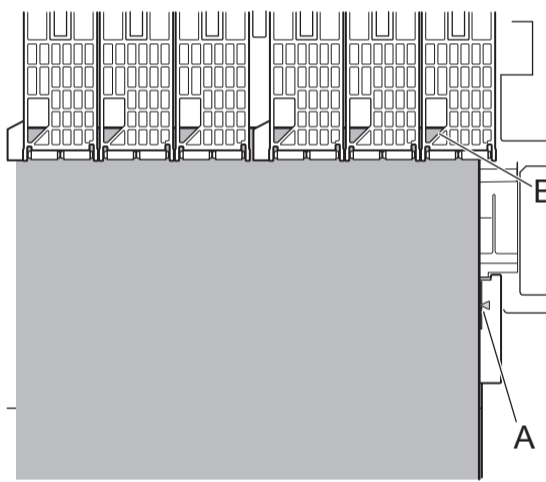

- 5** Lower the release lever to lock the paper and close the top cover.

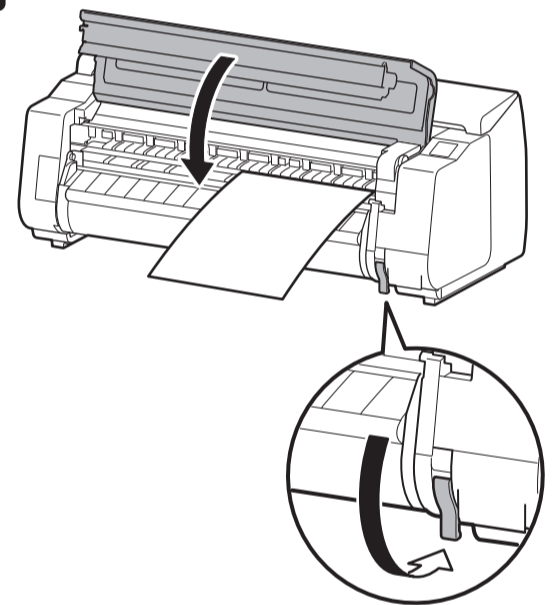

- 6** The screen for selecting the paper type appears. Tap the type of paper you loaded. In this case, tap **Coated papers** then **HW Coated HG**.



• If **The paper is loaded askew.** appears, repeat steps 2 to 5.

The remainder of this procedure differs depending on the model you are using. Check the name of the model you are using, and proceed to the following page.

For the PRO-2000: Go to p.10

For the PRO-4000, PRO-4000S, and PRO-6000S: Go to p.11

Perform Print Head Adjustment and Select the Connection Method on the PRO-2000

1 The paper starts feeding, and then the printer automatically starts charging the system with ink and adjusting the print head. Charging the system with ink and adjusting the print head for the first time takes about 50 minutes and uses 5 sheets of paper for adjustment.

Important

- Do not open the covers of the printer or turn the power off while the ink is charging for the first time and the print head adjustment is executing.

Note

- Charging the system with ink fills the system from the ink tanks to the print head. In addition, cleaning is performed to keep the printer in optimal condition. This may cause the remaining ink indicator and maintenance cartridge capacity indicator to drop some amount. The starter ink tank is for first-time installation. It is recommended that you purchase replacement ink tanks quickly.

2 Once a single sheet of the adjustment pattern has finished printing, lift up the release lever and remove the paper for adjustment.

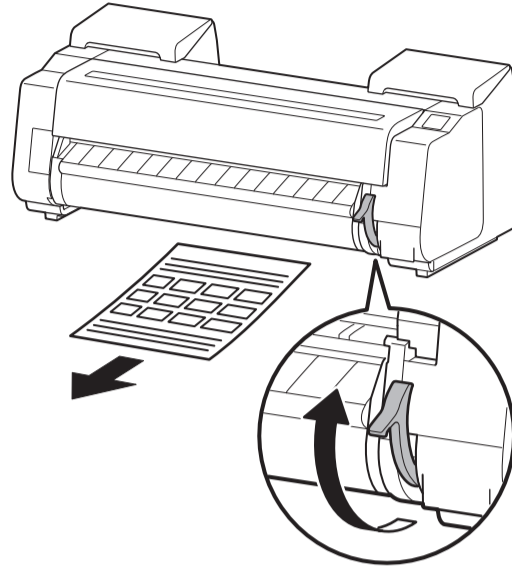

3 Load the next paper by referring to steps 2 to 5 on p.9. Print head adjustment uses 5 sheets of paper. Repeat steps 2 and 3 until the printing has finished.

4 Once the print head adjustment has finished, the screen below appears.

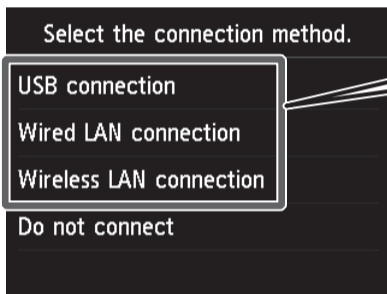

Tap the connection method to use.

Check the message about the connection method and tap **Yes** if there are no problems.

USB connection

This is the method for connecting the printer to a computer using a USB cable. Only 1 printer can be connected.

Do not connect the USB cable yet.

Wired LAN connection

This is the method for connecting the printer to the network using a LAN cable.

Wireless LAN connection

This is the method for connecting the printer to the network without using a cable.

5 If you selected **USB connection**

Proceed to "Connect to the Printer" on p.12.

If you selected **Wired LAN connection**

① Use the LAN cable to connect the wired LAN connector on the back of the printer to the hub port.

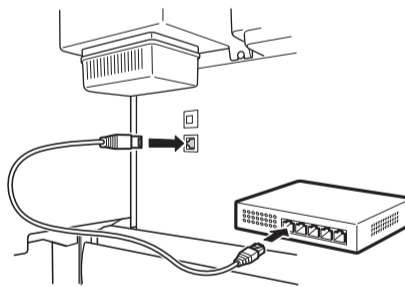

② Tap **OK**, and then proceed to "Connect to the Printer" on p.12.

Connect an Ethernet cable.

OK

If you selected **Wireless LAN connection**

To configure the wireless LAN settings using a computer, tap **Yes**, or to configure the wireless LAN settings on the printer, tap **No**, and proceed to "Connect to the Printer" on p.12.

Do you want to set up wireless LAN using a tool from a computer or smartphone, etc.?

Yes

No

If you selected **Do not connect**

Setup has finished at this point. However, the connection settings and software installation will need to be performed separately in order to use the printer from a computer. (Refer to "Connect to the Printer" on p.12)

To load roll paper after setup, tap the paper settings display area from the home screen, then (roll paper icon), then **Replace paper**, and follow the instructions on the screen.

For details, refer to the Online Manual that can be accessed by the procedure in "How to Display the Online Manuals" (p.14).

Select the Connection Method and Perform Print Head Adjustment on the PRO-4000, PRO-4000S, and PRO-6000S

1 When the screen for selecting the connection method appears, tap the connection method to use.

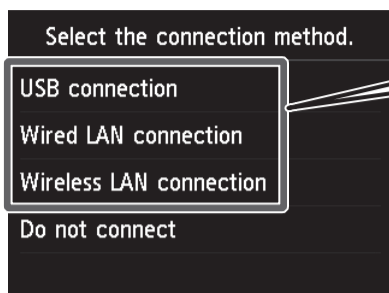

USB connection

This is the method for connecting the printer to a computer using a USB cable.

Only 1 printer can be connected.

Do not connect the USB cable yet.

Wired LAN connection

This is the method for connecting the printer to the network using a LAN cable.

Wireless LAN connection

This is the method for connecting the printer to the network without using a cable.

Check the message about the connection method and tap **Yes** if there are no problems.

2 If you selected **USB connection** or **Do not connect**

Proceed to step 3.

If you selected **Wired LAN connection**

① Use the LAN cable to connect the wired LAN connector on the back of the printer to the hub port.

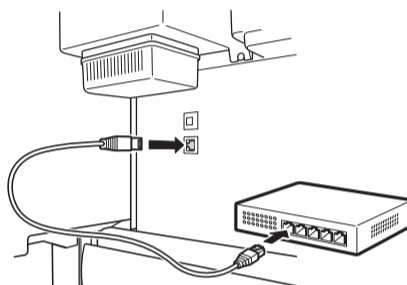

② Tap **OK**, and then proceed to step 3.

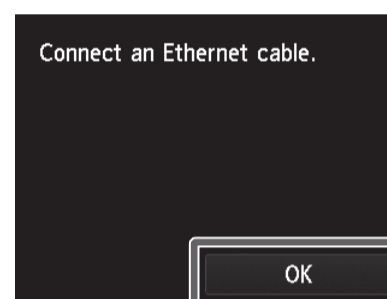

If you selected **Wireless LAN connection**

To configure the wireless LAN settings using a computer, tap **Yes**, or to configure the wireless LAN settings on the printer, tap **No**, and proceed to step 3.

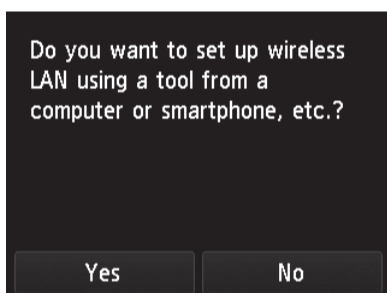

3 The paper starts feeding, and then the printer automatically starts charging the system with ink and adjusting the print head. Charging the system with ink and adjusting the print head for the first time takes about 55 minutes. During this time, configure the printer and computer connection settings and install the software. (Refer to "Connect to the Printer" on p.12)

Important • Do not open the covers of the printer or turn the power off while the ink is charging for the first time and the print head adjustment is executing.

Note • Charging the system with ink fills the system from the ink tanks to the print head. In addition, cleaning is performed to keep the printer in optimal condition. This may cause the remaining ink indicator and maintenance cartridge capacity indicator to drop some amount. The starter ink tank is for first-time installation. It is recommended that you purchase replacement ink tanks quickly.

• If you selected **Do not connect** in step 1, setup is finished at this point. However, the connection settings and software installation will need to be performed separately in order to use the printer from a computer. (Refer to "Connect to the Printer" on p.12)

To load roll paper after setup, tap the paper settings display area from the home screen, then  (roll paper icon), then **Replace paper**, and follow the instructions on the screen.

For details, refer to the Online Manual that can be accessed by the procedure in "How to Display the Online Manuals" (p.14).

Connect to the Printer

The printer connection settings and software installation are performed using a computer. However, if you selected **Wireless LAN connection** -> **Yes** -> **No** in steps 4 to 5 on p.10 or steps 1 to 2 on p.11, configure the wireless LAN settings only using the printer. Proceed to "Configure Wireless LAN Settings on the Printer" on p.13.

1 Enter the following URL in the web browser of your computer to access the website.

<http://canon.com/ijsetup>

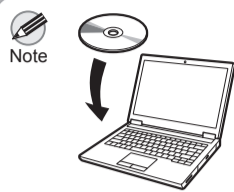

- If you are using a Windows PC, you can also start this from the CD-ROM.
- When using Windows 10, Windows 8.1 or Windows 8, follow the procedure below for start up the setup file after inserting the setup CD.
 - ① Click or **File Explorer** on the taskbar.
 - ② Select **This PC** or **Computer** on the left side of the opened window.
 - ③ Double-click the CD-ROM icon on the right side of the window.
If the contents of the CD-ROM appear, double-click **MSETUP4.EXE**.
- If you have started from the CD-ROM, proceed to step 4.

2 Click **Set Up**. Perform the remaining operations by following the instructions on the screen.



3 Click **Download** to download the setup files.

If a warning screen about downloading appears, select **Do not block**, **Allow**, etc. to proceed with the operation.



4 Run the file you downloaded and click **Start Setup**.

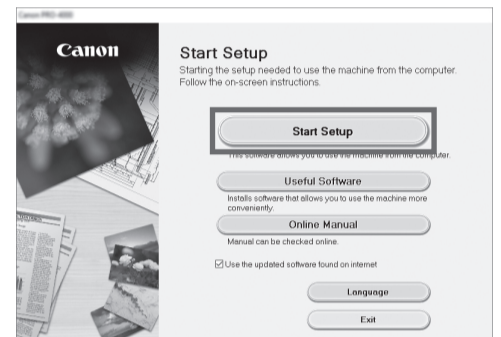

Configure the settings by following the instructions on the screen.

5 Select the printer connection method and click **Next**.

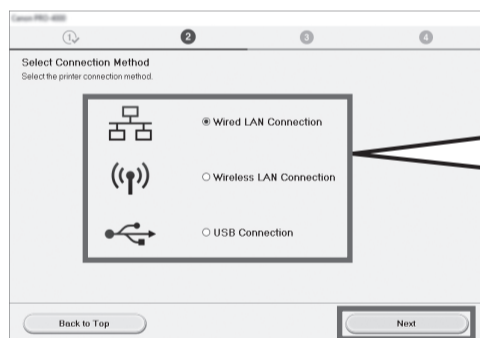

Select the same method that you selected in step 4 on p.10 or step 1 on p.11.

Wired LAN connection

This is the method for connecting the printer to the network using a LAN cable.

Wireless LAN connection

This is the method for connecting the printer to the network without using a cable.

USB connection

This is the method for connecting the printer to a computer using a USB cable.

Only 1 printer can be connected.

For the USB cable connection, first select the connection method and then follow the instructions on the screen.

Configure the remaining settings by following the instructions on the screen.

6 When the following screen appears, you can use the printer. **Next**, click Next to proceed to installing the software.

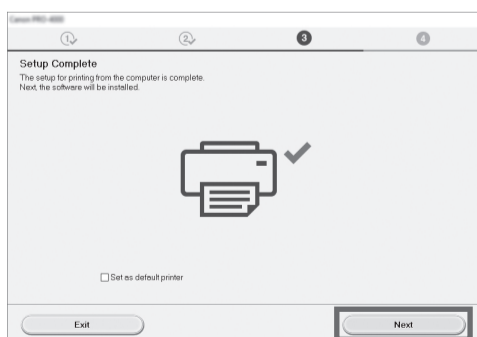

7 When the following screen appears, select the software to install and click **Next**.

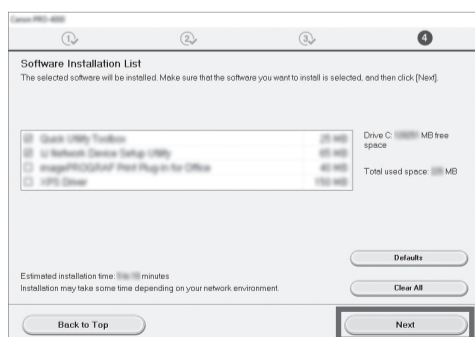

Configure the remaining settings by following the instructions on the screen. This completes the connection with the computer.

Configure Wireless LAN Settings on the Printer

If you selected **Wireless LAN connection** -> **Yes** -> **No** in steps 4 to 5 on p.10 or steps 1 to 2 on p.11, configure the wireless LAN settings using the printer touch screen.

- 1** Once the print head adjustment has finished, check that the following screen appears and tap **OK**.



- Note**
- If the following message appears, the printer initial settings are not finished. Wait until the above screen appears.
Checking the nozzle.
Filling the print head with ink...
Cleaning...

- 2** Select and tap the connection method.

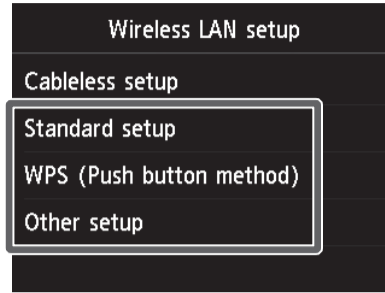

Configure the wireless LAN settings by following the instructions on the screen.

- 3** When the home screen appears and (P) appears, the wireless LAN settings are complete.

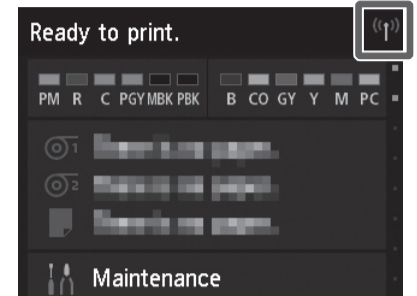

- Note**
- Before using the printer, the software needs to be installed on the computer that is connected to the printer.

- Note**
- Once you have finished setting up the printer and software, it is recommended that you execute color calibration. You can compensate for variations in color tone due to differences between printers and variations due to aging by executing color calibration. Color calibration is executed using paper for adjustment that supports color calibration. For details on other supported paper, refer to "List of Paper Information" in the Online Manual. To execute color calibration, select **Maintenance** from the home screen -> **Color calibration** -> **Auto adjust**. Executing color calibration takes about 10 minutes.
 - If you are using color calibration, it is convenient to configure the function for notifying the execution time (Calibration guide setting). For details on this function, refer to "Performing Color Calibration" in the Online Manual.

Store Accessories in the Pockets

- 1** Store accessories such as the 3-inch paper core attachment in the accessory pocket.

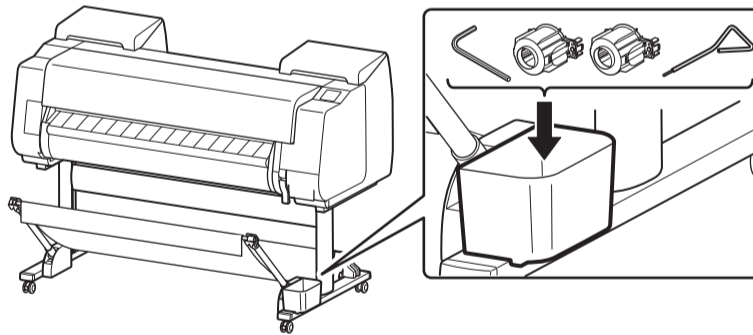

- Note**
- When the setup is completed, refer to the various manuals to use the printer. Refer to "The Manuals Supplied with This Printer" on p.2.



How to Display the Online Manuals

Online Manual that describes how to use the printer in detail is published on the Web. Access it using the following procedure as needed.

- 1** Enter the following URL in the web browser of a computer, smartphone, etc.
Alternatively, you can also scan the following QR code and access the website from the scan result.



- 2** Click or tap **Read Online Manual**.
Perform the remaining operations by following the instructions on the screen to display the Online Manual.



Responding to Messages

Error messages may appear on the touch screen of the operation panel when setting up printer. If so, it may not indicate a problem with the printer, and the issue may be easily resolved. Common messages and the causes are listed here with corrective actions. For details on other messages, refer to the Online Manual.

Message	Cause	Corrective Action
The ink tank is not installed. Install the ink tank properly.	There is no ink tank loaded.	Load or reload the ink tank. (Refer to step 1 on p.6 to step 10 on p.7)
	The ink tank is not firmly installed all the way in.	
Print head cannot be recognized correctly. Open the top cover and install the correct print head.	The print head is not installed.	Install the print head. (Refer to steps 1-9 on p.8)
	Electrical contact failure in the print head.	Remove the print head, make sure that no debris becomes adhered to the contacts on the print head and the carriage, and then reinstall the print head.
The paper is loaded askew. Lift the release lever and reload the paper.	The paper may not be aligned with the paper alignment line.	Reload the paper so that the edge of the paper is aligned with the paper alignment line. (Refer to steps 2-6 on p.9)
Cannot detect the paper size. Lift the release lever and reload the paper.	The roll paper is fed even though cut sheet remains selected as the paper source.	Release the release lever and reload the paper. Tap the paper settings display area from the home screen, then  (roll paper icon), then Replace paper , and feed the roll paper again. For details, refer to "Removing the Upper Roll from the Printer" and "Loading the Upper Roll on the Printer" in the Online Manual.
Hardware error ECxx-xxxx (x represents a letter or number) Printer error has occurred. Turn the device off, wait a while, and then turn it on again.	The belt stopper or the tape inside the top cover has not been removed.	Turn off the power, open the top cover, and remove the tape and the belt stopper, then turn the power on.
	You may have encountered an error that cannot be resolved.	Turn off the printer and wait at least 3 seconds before restoring the power. If the message appears again, write down the error code and message, turn off the printer, and contact your Canon dealer for assistance.
Error Ecxxx-xxxx (x represents a letter or number) Printer error has occurred. See the manual and contact the service center.	You may have encountered an error that cannot be resolved.	Write down the error code and message, turn off the printer, and contact your Canon dealer for assistance.