

Dell EMC PowerEdge T340

Technical Specifications

Notes, cautions, and warnings

 **NOTE:** A NOTE indicates important information that helps you make better use of your product.

 **CAUTION:** A CAUTION indicates either potential damage to hardware or loss of data and tells you how to avoid the problem.

 **WARNING:** A WARNING indicates a potential for property damage, personal injury, or death.

Chapter 1: Technical specifications	4
Chassis dimensions.....	4
System weight.....	5
Processor specifications.....	5
Supported operating systems.....	5
PSU specifications.....	5
Cooling fan specifications.....	6
System battery specifications.....	6
Expansion card specifications.....	6
Memory specifications.....	6
Storage controller specifications.....	7
Drive specifications.....	7
Drives.....	7
Optical drives.....	7
Tape drives.....	7
Ports and connectors specifications.....	8
USB ports specifications.....	8
NIC ports specifications.....	8
Serial connector specifications.....	8
VGA ports specification.....	8
IDSDM module.....	8
Video specifications.....	9
Environmental specifications.....	9
Standard operating temperature.....	10
Expanded operating temperature.....	10
Particulate and gaseous contamination specifications.....	11

Technical specifications

The technical and environmental specifications of your system are outlined in this section.

Topics:

- Chassis dimensions
- System weight
- Processor specifications
- Supported operating systems
- PSU specifications
- Cooling fan specifications
- System battery specifications
- Expansion card specifications
- Memory specifications
- Storage controller specifications
- Drive specifications
- Ports and connectors specifications
- Video specifications
- Environmental specifications

Chassis dimensions

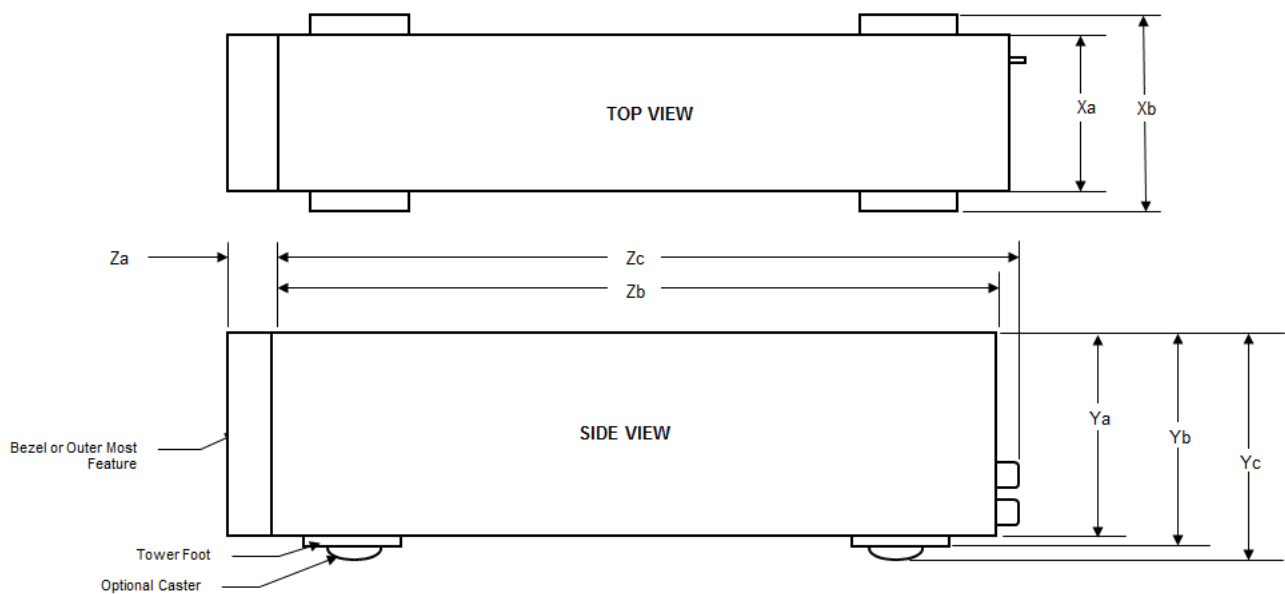

Figure 1. Chassis dimensions

Table 1. Dell EMC PowerEdge T340 chassis dimensions

Xa	Xb	Ya	Yb	Yc	Za	Zb	Zc
218 mm (8.58 inches)	307.9 mm (12.12 inches)	430.3 mm (16.94 inches)	443.3 mm (17.45 inches)	471.3 mm (18.56 inches)	With bezel: 14.1 mm (0.56 inches)	545.4 mm (21.47 inches)	589.1 mm (23.19 inches)

System weight

Table 2. Dell EMC PowerEdge T340 system chassis weight

System configuration	Maximum weight (with all drives/SSDs)
8 x 3.5-inch drives	26 Kg (57.32 lb)

Processor specifications

Table 3. Dell EMC PowerEdge T340 processor specifications

Supported processor	Number of processors supported
Intel Xeon processor E-2200 product family	One
Intel Core i3 9100 processor	
Intel Pentium G5420 processor	
Intel Celeron G4930 processor	
Intel Xeon processor E-2100 product family	
Intel Core i3 8100 processor	
Intel Pentium G5500 processor	
Intel Celeron G4900 processor	

Supported operating systems

The Dell EMC PowerEdge T340 supports the following operating systems:

- Canonical Ubuntu LTS
- Citrix Hypervisor
- Microsoft Windows Server
- Red Hat Enterprise Linux
- SUSE Linux Enterprise Server
- VMware ESXi

 **NOTE:** For more information, go to www.dell.com/ossupport.

PSU specifications

The Dell EMC PowerEdge T340 system supports up to two AC power supply units (PSUs).

Table 4. Dell EMC PowerEdge T340 PSU specifications

PSU	Class	Heat dissipation (maximum)	Frequency	Voltage	AC		DC	Current
					High line (100–240 V)	Low line (100–120 V)		
495 W AC	Platinum	1908 BTU/hr	50/60 Hz	100–240 V AC, autoranging	495 W	NA	N/A	6.5 A–3 A
350 W AC	Bronze	1455 BTU/hr	50/60 Hz	100–240 V AC, autoranging	350 W	NA	N/A	5.5 A–3 A

Cooling fan specifications

The Dell EMC PowerEdge T340 system supports one system cooling fan.

i **NOTE:** When selecting or upgrading the system configuration, to ensure optimum power utilization, verify the system power consumption with the Dell Energy Smart Solution Advisor available at Dell.com/ESSA.

System battery specifications

The Dell EMC PowerEdge T340 system supports CR 2032 3.0-V lithium coin cell system battery.

Expansion card specifications

The Dell EMC PowerEdge T340 system supports up to four PCI express (PCIe) Generation 3.

Table 5. Expansion card slots supported on the system board

PCIe slot	Processor Connection	PCIe slot height	PCIe slot length	Slot width
Slot 1 (Gen3)	Processor	Full Height	Half Length	x8 link in x8 slot
Slot 2 (Gen3)	Processor	Full Height	Half Length	x8 link in x16 slot
Slot 3 (Gen3)	Platform Controller Hub	Full Height	Half Length	x1
Slot 4 (Gen3)	Platform Controller Hub	Full Height	Half Length	x4 link in x8 slot

i **NOTE:** The expansion cards are not hot swappable.

Memory specifications

The Dell EMC PowerEdge T340 system supports the following memory specifications for optimized operation:

Table 6. Memory specifications

DIMM type	DIMM rank	DIMM capacity	Minimum RAM	Maximum RAM
UDIMM	Single rank	8 GB	8 GB	32 GB
		16 GB	16 GB	64 GB
	Dual rank	8 GB	8 GB	32 GB
		16 GB	16 GB	64 GB

Table 6. Memory specifications

Memory module sockets	Speed
Four 288-pin	2666 MT/s 2400 MT/s 2133 MT/s

NOTE: 3200 MT/s UDIMM is compatible from BIOS version 2.5.1 but downshift to 2666 MT/s operational speed.

Storage controller specifications

The Dell EMC PowerEdge T340 system supports the following controller cards:

Table 7. Dell EMC PowerEdge T340 system controller cards

Internal controllers	External controllers
<ul style="list-style-type: none">PERC H730PPERC H330S140HBA330	<ul style="list-style-type: none">12 Gb/s Ext SAS HBAHBA355e

Drive specifications

Drives

The Dell EMC PowerEdge T340 system supports:

- 4 x 3.5-inch SAS, SATA drives, 2.5-inch hotplug drives
- 8 x 3.5-inch SAS, SATA drives, 2.5-inch hotplug drives

NOTE: 2.5-inch drives in 3.5-inch carriers are supported for SAS, and SATA SSD drives.

Optical drives

The Dell EMC PowerEdge T340 system supports the following optical drives.

Table 8. Supported optical drive type

Supported drive type	Supported number of drives
Dedicated SATA DVD-ROM drive or DVD +/-RW drive	One

Tape drives

The Dell EMC PowerEdge T340 system supports up to two dedicated 5.25-inch tape drives.

Ports and connectors specifications

USB ports specifications

Table 9. Dell EMC PowerEdge T340 system USB port specifications

Front panel	Back panel	Internal USB
<ul style="list-style-type: none">One USB 3.0-compliant portOne iDRAC USB MGMT port (USB 2.0) <p>NOTE: The micro USB 2.0 compliant port can only be used as an iDRAC Direct or a management port.</p>	<ul style="list-style-type: none">Two USB 3.0-compliant portsFour USB 2.0-compliant ports	<ul style="list-style-type: none">One internal USB 3.0-compliant port

NIC ports specifications

The Dell EMC PowerEdge T340 system supports up to two 10/100/1000 Mbps Network Interface Controller (NIC) ports that are located on the back panel.

Serial connector specifications

The Dell EMC PowerEdge T340 system supports one serial connector on the back panel, which is a 9-pin connector, Data Terminal Equipment (DTE), 16550-compliant.

VGA ports specification

The Dell EMC PowerEdge T340 system supports one 15-pin VGA port, on the back of the system.

IDSDM module

The Dell EMC PowerEdge T340 system supports optional Internal Dual SD module (IDSDM) module.

The module supports three microSD cards; two cards for IDSDM and one card for vFlash. In 14th generation of PowerEdge servers, the IDSDM or vFlash module is combined into a single card module, and is available in the following configurations:

- vFlash or
- vFlash and IDSDM

Table 10. Supported microSD card storage capacity

IDSDM card	vFlash card
<ul style="list-style-type: none">16 GB32 GB64 GB	<ul style="list-style-type: none">16 GB

NOTE: There are two dip switches on the IDSDM or vFlash module for write-protection.

NOTE: One IDSDM card slot is dedicated for redundancy.

NOTE: Use Dell EMC branded microSD cards that are associated with the IDSDM or vFlash configured systems.

Video specifications

The Dell EMC PowerEdge T340 system supports Matrox G200eR2 graphics card with 16 MB capacity.

Table 11. Supported video resolution options

Resolution	Refresh rate	Color depth (bits)
640x480	60, 70	8, 16, 24
800x600	60, 75, 85	8, 16, 24
1024x768	60, 75, 85	8, 16, 24
1152x864	60, 75, 85	8, 16, 24
1280x1024	60, 75	8, 16, 24

Environmental specifications

NOTE: For additional information about environmental certifications, refer to the *Product Environmental Datasheet* located with the Manuals & Documents on www.dell.com/support/home.

Table 12. Temperature specifications

Temperature	Specifications
Storage	-40–65°C (-40–149°F)
Continuous operation (for altitude less than 950 m or 3117 ft)	10–35°C (50–95°F) with no direct sunlight on the equipment
Fresh air	For information about fresh air, see the Expanded operating temperature section.
Maximum temperature gradient (operating and storage)	20°C/h (68°F/h)

Table 13. Relative humidity specifications

Relative humidity	Specifications
Storage	5% to 95% RH with 33°C (91°F) maximum dew point. Atmosphere must be noncondensing at all times.
Operating	10% to 80% RH with 29°C (84.2°F) maximum dew point.

Table 14. Maximum vibration specifications

Maximum vibration	Specifications
Operating	0.26 G _{rms} at 5 Hz to 350 Hz (all operation orientations)
Storage	1.88 G _{rms} at 10 Hz to 500 Hz for 15 minutes (all six sides tested)

Table 15. Maximum shock pulse specifications

Maximum shock pulse	Specifications
Operating	Six consecutively executed shock pulses in the positive and negative x, y, and z axis of 6 G for up to 11 ms.
Storage	Six consecutively executed shock pulses in the positive and negative x, y, and z axis (one pulse on each side of the system) of 71 G for up to 2 ms.

Table 16. Maximum altitude specifications

Maximum altitude	Specifications
Operating	3048 m (10,000 ft)
Storage	12,000 m (39,370 ft)

Table 17. Operating temperature derating specifications

Operating temperature derating	Specifications
Up to 35°C (95°F)	Maximum temperature is reduced by 1°C/300 m (1°F/547 ft), above 950 m (3,117 ft).
35–40°C (95–104°F)	Maximum temperature is reduced by 1°C/175 m (1°F/319 ft), above 950 m (3,117 ft).
40–45°C (104–113°F)	Maximum temperature is reduced by 1°C/125 m (1°F/228 ft), above 950 m (3,117 ft).

Standard operating temperature

Table 18. Standard operating temperature specifications

Standard operating temperature	Specifications
Continuous operation (for altitude less than 950 m or 3117 ft)	10–35°C (50–95°F) with no direct sunlight on the equipment.

Expanded operating temperature

Table 19. Expanded operating temperature specifications

Expanded operating temperature	Specifications
Continuous operation	<p>5°C–40°C at 5% to 85% RH with 29°C dew point.</p> <p>i NOTE: Outside the standard operating temperature (10°C–35°C), the system can operate continuously in temperatures as low as 5°C and as high as 40°C.</p> <p>For temperatures 35°C– 40°C, derate maximum allowable temperature by 1°C per 175 m (1°F per 319 ft) above 950 m (3,117 ft).</p>
≤ 1% of annual operating hours	<p>-5°C–45°C at 5% to 90% RH with 29°C dew point.</p> <p>i NOTE: Outside the standard operating temperature (10°C–35°C), the system can operate down to -5°C or up to 45°C for a maximum of 1% of its annual operating hours.</p> <p>For temperatures 40°C– 45°C, derate maximum allowable temperature by 1°C per 125 m (1°F per 228 ft) above 950 m (3,117 ft).</p>

i **NOTE:** When operating in the expanded temperature range, the performance of the system may be impacted.

i **NOTE:** When operating in the expanded temperature range, ambient temperature warnings may be reported on the System Event Log.

Expanded operating temperature restrictions

- Do not perform a cold startup of the system below 5°C.

- The operating temperature specified is for a maximum altitude of 950 m for Fresh Air cooling.
- Two redundant power supply units are required.
- Cooling redundancy is not supported due to single fan only in system.
- Support up to 80 W processor.
- One system fan is required.
- Non-Dell qualified peripheral cards and/or peripheral cards greater than 25 W are not supported.
- GPU is not supported.
- Tape backup unit is supported.

Particulate and gaseous contamination specifications

The following table defines the limitations that help avoid any damages to the IT equipment and/or, or both failure from particulate and gaseous contamination. If the levels of particulate or gaseous pollution exceed the specified limitations and results in equipment damage or failure, you must rectify the environmental conditions. Remediation of environmental conditions is the responsibility of the customer.

Table 20. Particulate contamination specifications

Particulate contamination	Specifications
Air filtration	Data center air filtration as defined by ISO Class 8 per ISO 14644-1 with a 95% upper confidence limit. <i>i</i> NOTE: This condition applies to data center environments only. Air filtration requirements do not apply to IT equipment designed to be used outside a data center, in environments such as an office or factory floor. <i>i</i> NOTE: Air entering the data center must have MERV11 or MERV13 filtration.
Conductive dust	Air must be free of conductive dust, zinc whiskers, or other conductive particles. <i>i</i> NOTE: This condition applies to data center and non-data center environments.
Corrosive dust	<ul style="list-style-type: none"> • Air must be free of corrosive dust. • Residual dust present in the air must have a deliquescent point less than 60% relative humidity. <i>i</i> NOTE: This condition applies to data center and non-data center environments.

Table 21. Gaseous contamination specifications

Gaseous contamination	Specifications
Copper Coupon Corrosion	<300 Å/month per Class G1 as defined by ANSI/ISA71.04-1985.
Silver Coupon Corrosion	<200 Å/month as defined by AHSRAE TC9.9.

i **NOTE:** Maximum corrosive contaminant levels measured at ≤50% relative humidity.