

Version 1.0
September 2016



Xerox[®] Phaser[®] 3330 Printer

User Guide



©2016 Xerox Corporation. All rights reserved. Xerox®, Xerox and Design®, Phaser®, PhaserSMART®, PhaserMatch®, PhaserCal®, PhaserMeter™, CentreWare®, PagePack®, eClick®, PrintingScout®, Walk-Up®, WorkCentre®, FreeFlow®, SMARTsend®, Scan to PC Desktop®, MeterAssistant®, SuppliesAssistant®, Xerox Secure Access Unified ID System®, Xerox Extensible Interface Platform®, ColorQube®, Global Print Driver®, and Mobile Express Driver® are trademarks of Xerox Corporation in the United States and / or other countries.

Adobe®, Adobe PDF logo, Reader®, Adobe® Type Manager®, ATM™, Flash®, Macromedia®, Photoshop®, and PostScript® are trademarks or registered trademarks of Adobe Systems, Inc.

Apple®, Bonjour®, EtherTalk™, TrueType®, iPad®, iPhone®, iPod®, iPod touch®, AirPrint® and the AirPrint®, Mac®, and Mac OS® are trademarks or registered trademarks of Apple Inc. in the U.S. and other countries.

HP-GL®, HP-UX®, and PCL® are registered trademarks of Hewlett-Packard Corporation in the United States and/or other countries.

IBM® and AIX® are registered trademarks of International Business Machines Corporation in the United States and/or other countries.

Microsoft®, Windows Vista®, Windows®, and Windows Server® are registered trademarks of Microsoft Corporation in the United States and other countries.

Novell®, NetWare®, NDPS®, NDS®, IPX™, and Novell Distributed Print Services™ are trademarks or registered trademarks of Novell, Inc. in the United States and other countries.

SGI® and IRIX® are registered trademarks of Silicon Graphics International Corp. or its subsidiaries in the United States and/or other countries.

Sun, Sun Microsystems, and Solaris are trademarks or registered trademarks of Oracle and/or its affiliates in the United States and other countries.

McAfee®, ePolicy Orchestrator®, and McAfee ePO™ are trademarks or registered trademarks of McAfee, Inc. in the United States and other countries.

UNIX® is a trademark in the United States and other countries, licensed exclusively through X/ Open Company Limited.

PANTONE® and other Pantone, Inc. trademarks are the property of Pantone, Inc.

Table of Contents

1 Safety.....	1-1
Notices and Safety.....	1-1
Electrical Safety.....	1-2
General Guidelines.....	1-2
Power Cord.....	1-2
Emergency Power Off.....	1-3
Laser Safety.....	1-3
Operational Safety.....	1-3
Operational Guidelines.....	1-3
Ozone Release.....	1-4
Printer Location.....	1-4
Printer Supplies.....	1-4
Maintenance Safety.....	1-5
Printer Symbols.....	1-5
Environmental, Health, and Safety Contact Information.....	1-9
2 Features.....	2-1
Parts of the Printer.....	2-1
Front View.....	2-1
Rear View.....	2-2
Internal Components.....	2-2
Control Panel.....	2-3
Information Pages.....	2-4
Accessing the Information Pages.....	2-4
Configuration Report.....	2-4
Power Saver Mode.....	2-5
Power Saver Levels.....	2-5
Setting the Power Saver Mode Timers at the Control Panel.....	2-5
Exiting Power Saver Mode.....	2-5
Administration Features.....	2-6
Xerox® CentreWare® Internet Services.....	2-6
Accessing Xerox®CentreWare® Internet Services.....	2-6
Locating the IP Address of the Printer.....	2-6
Maintenance Assistant.....	2-6
Enabling Maintenance Assistant.....	2-6
More Information.....	2-8

3 Installation and Setup.....	3-1
Installation and Setup Overview.....	3-1
Selecting a Location for the Printer.....	3-2
Connecting the Printer.....	3-2
Selecting a Connection Method.....	3-2
Connecting the Printer to the Network.....	3-3
Connecting to a Computer Using USB.....	3-3
Turning On/Off the Printer.....	3-3
Configuring Network Settings.....	3-6
About TCP/IP and IP Addresses.....	3-6
Installing the Software.....	3-6
Operating System Requirements.....	3-6
Installing Drivers and Utilities for Windows.....	3-7
Installing Print Drivers for Macintosh OS X Version 10.9 and Later.....	3-7
Installing the Print Drivers for UNIX and Linux.....	3-9
Other Drivers.....	3-9
Installing the Printer as a Web Service on Devices.....	3-9
Installing a WSD Printer Using the Add Device Wizard.....	3-9
Installing a WSD Printer Manually Using the Add Printer Wizard.....	3-10
AirPrint, Mopria, Google Cloud Print, and NFC.....	3-10
4 Paper and Media.....	4-1
Supported Paper.....	4-1
Ordering Paper.....	4-1
General Paper Loading Guidelines.....	4-1
Paper That Can Damage Your Printer.....	4-1
Paper Storage Guidelines.....	4-2
Supported Paper Types and Weights.....	4-2
Supported Standard Paper Sizes.....	4-3
Supported Custom Paper Sizes.....	4-3
Supported Paper Types and Weights for Automatic 2-Sided Printing.....	4-3
Supported Standard Paper Sizes for Automatic 2-Sided Printing.....	4-4
Supported Custom Paper Sizes for Automatic 2-Sided Printing.....	4-5
Loading Paper.....	4-6
Loading Paper in the Bypass Tray.....	4-6
Loading Paper in Tray 1 and Optional Tray 2.....	4-8

Setting Paper Size and Type.....	4-10
Setting the Paper Size.....	4-10
Setting the Paper Type.....	4-11
Printing on Special Paper.....	4-12
Envelopes.....	4-12
Guidelines for Printing Envelopes.....	4-12
Loading Envelopes in the Bypass Tray.....	4-12
Labels.....	4-14
Guidelines for Printing Labels.....	4-14
Loading Labels in the Bypass Tray.....	4-14
Transparencies.....	4-15
Guidelines for Printing Transparencies.....	4-15
5 Printing.....	5-1
Printing Overview.....	5-1
Selecting Printing Options.....	5-1
Print Driver Help.....	5-2
Windows Printing Options.....	5-2
Setting Default Printing Options for Windows.....	5-2
Selecting Windows Print Options for an Individual Job.....	5-3
Saving a Set of Commonly Used Printing Options for Windows.....	5-3
Macintosh Printing Options.....	5-3
Selecting Printing Options for Macintosh.....	5-3
Saving a Set of Commonly Used Printing Options for Macintosh.....	5-4
Linux Printing Options.....	5-4
Launching Xerox® Printer Manager.....	5-4
Printing from a Linux Workstation.....	5-4
Printing Features.....	5-5
Printing on Both Sides of the Paper.....	5-5
Selecting Paper Options for Printing.....	5-6
Printing Multiple Pages to a Single Sheet.....	5-6
Scaling.....	5-6
Print Quality.....	5-6
Printing from a USB Flash Drive.....	5-7
6 Maintenance.....	6-1
Cleaning the Printer.....	6-1
General Precautions.....	6-1
Cleaning the Exterior.....	6-2

Ordering Supplies.....	6-2
When to Order Supplies.....	6-2
Viewing Printer Supply Status.....	6-2
Consumables.....	6-3
Routine Maintenance Items.....	6-3
Toner Cartridges.....	6-4
General Precautions for the Toner Cartridge.....	6-4
Replacing a Toner Cartridge.....	6-4
Drum Cartridges.....	6-4
General Precautions for the Drum Cartridge.....	6-4
Replacing a Drum Cartridge.....	6-5
Recycling Supplies.....	6-5
Moving the Printer.....	6-5
Billing and Usage Counters Information.....	6-6

7 Troubleshooting.....7-1

General Troubleshooting.....	7-1
Restarting the Printer.....	7-1
Printer Fails to Power On.....	7-1
Printer Resets or Turns Off Frequently.....	7-2
Document Prints from Wrong Tray.....	7-2
Automatic 2-Sided Printing Problems.....	7-2
Paper Tray Fails to Close.....	7-3
Printing Takes Too Long.....	7-3
Printer Fails to Print.....	7-3
Printer Makes Unusual Noises.....	7-4
Condensation has Formed Inside the Printer.....	7-5
Paper Jams.....	7-5
Minimizing Paper Jams.....	7-5
Locating Paper Jams.....	7-6
Clearing Paper Jams.....	7-8
Clearing Paper Jams from the Bypass Tray.....	7-8
Clearing Paper Jams from Tray 1.....	7-9
Clearing Paper Jams from Tray 2.....	7-11
Clearing Paper Jams from Inside the Front Cover.....	7-14
Clearing Paper Jams from the Back of the Printer.....	7-16
Clearing Paper Jams from the Duplex Unit.....	7-19
Clearing Paper Jams from the Output Area.....	7-21
Troubleshooting Paper Jams.....	7-21
Multiple Sheets Pulled Together.....	7-21
Paper Misfeeds.....	7-22

Label and Envelope Misfeeds.....7-22

Paper Jam Message Stays On.....7-23

Jams During Automatic 2-Sided Printing.....7-23

Print-Quality Problems.....7-23

 Controlling Print Quality.....7-24

 Solving Print-Quality Problems.....7-24

Getting Help.....7-28

 Control Panel Messages.....7-28

 Available Information Pages.....7-28

 Accessing Available Information Pages.....7-28

 Online Support Assistant.....7-28

 More Information.....7-29

A Specifications.....A-1

Printer Configurations and Options.....A-1

 Configurations.....A-1

 Standard Features.....A-1

Physical Specifications.....A-2

 Weights and Dimensions.....A-2

 Clearance Requirements for Standard Configuration.....A-2

Environmental Specifications.....A-3

 Temperature.....A-3

 Relative Humidity.....A-3

 Elevation.....A-3

Electrical Specifications.....A-3

 Power Supply Voltage and Frequency.....A-3

 Power Consumption.....A-3

Performance Specifications.....A-4

 Printer Warm-up Time.....A-4

 Print Speed.....A-4

B Regulatory Information.....B-1

Basic Regulations.....B-1

 ENERGY STAR® Qualified Product.....B-1

 United States FCC Regulations.....B-1

 Canada.....B-2

 European Union.....B-2

 European Union Lot 4 Imaging Equipment Agreement
 Environmental Information.....B-2

 Environmental Information Providing Environmental
 Solutions and Reducing Cost.....B-2

Table of Contents

Germany.....B-4
 Germany - Blue Angel.....B-4
 Blendschutz.....B-4
 Lärmemission.....B-5
 Importeur.....B-5
Turkey RoHS Regulation.....B-5
Regulatory Information for 2.4 GHz Wireless Network
 Adapter.....B-5
Material Safety Data Sheets.....B-5

C Recycling and Disposal.....C-1

All Countries.....C-1
North America.....C-1
European Union.....C-1
 Domestic/Household Environment.....C-1
 Professional/Business Environment.....C-2
Collection and Disposal of Equipment and Batteries.....C-2
 Business Users in the European Union.....C-2
 Disposal Outside of the European Union.....C-2
Battery Symbol Note.....C-3
Battery Removal.....C-3
Other Countries.....C-3

Safety

Your printer and the recommended supplies have been designed and tested to meet strict safety requirements. Attention to the following information ensures the continued and safe operation of your Xerox printer.

Notices and Safety

Read the following instructions carefully before operating your printer. Refer to these instructions to ensure the continued safe operation of your printer.

Your Xerox® printer and supplies are designed and tested to meet strict safety requirements. These include safety agency evaluation and certification, and compliance with electromagnetic regulations and established environmental standards.

The safety and environment testing and performance of this product have been verified using Xerox® materials only.

Note

Unauthorized alterations, which can include the addition of new functions or the connection of external devices, can affect the product certification. For more information, contact your Xerox representative.

Electrical Safety

General Guidelines

Warning

- Do not push objects into slots or openings on the printer. Touching a voltage point or shorting out a part could result in fire or electric shock.
- Do not remove the covers or guards that are fastened with screws unless you are installing optional equipment and are instructed to do so. Turn off the printer when performing these installations. Disconnect the power cord when removing covers and guards for installing optional equipment. Except for user-installable options, there are no parts that you can maintain or service behind these covers.

Warning

The following are hazards to your safety:

- The power cord is damaged or frayed.
- Liquid is spilled into the printer.
- The printer is exposed to water.
- The printer emits smoke, or the surface is unusually hot.
- The printer emits unusual noise or odors.
- The printer causes a circuit breaker, fuse, or other safety device to activate.

If any of these conditions occur, do the following:

1. Turn off the printer immediately.
2. Disconnect the power cord from the electrical outlet.
3. Call an authorized service representative.

Power Cord

- Use the power cord supplied with your printer.
- Do not use an extension cord or remove or modify the power cord plug.
- Plug the power cord directly into a properly grounded electrical outlet. Ensure that each end of the cord is connected securely. If you do not know if an outlet is grounded, ask an electrician to check the outlet.
- Do not use a ground adapter plug to connect the printer to an electrical outlet that does not have a ground connection terminal.

Warning

Avoid the potential of electrical shock by ensuring that the printer is grounded properly. Electrical products can be hazardous if misused.

- Verify that the printer is plugged into an outlet that is providing the correct voltage and power. Review the electrical specification of the printer with an electrician if necessary.
- Do not place the printer in an area where people can step on the power cord.

- Do not place objects on the power cord.
- If the power cord becomes frayed or worn, replace it.
- Do not plug or unplug the power cord while the power switch is in the On position.
- To avoid electrical shock and damage to the cord, grasp the plug when unplugging the power cord.
- Ensure that the electrical outlet is near the printer and is easily accessible.

The power cord is attached to the printer as a plug-in device on the back of the printer. If it is necessary to disconnect all electrical power from the printer, disconnect the power cord from the electrical outlet.

Emergency Power Off

If any of the following conditions occur, power the printer off immediately. Disconnect the power cord from the electrical outlet. Contact an authorized Xerox service representative to correct the problem if any of the following occurs:

- The equipment emits unusual odors or makes unusual noises.
- The power cable is damaged or frayed.
- A wall panel circuit breaker, fuse, or other safety device has been tripped.
- Liquid is spilled into the printer.
- The printer is exposed to water.
- Any part of the printer is damaged.

Laser Safety

This printer complies with laser product performance standards set by governmental, national, and international agencies and is certified as a Class 1 Laser Product. The printer does not emit hazardous light because the beam is enclosed completely during all modes of customer operation and maintenance.

Laser Warning

Use of controls, adjustments, or performance of procedures other than those specified in this manual can result in hazardous radiation exposure.

Operational Safety

Your printer and supplies were designed and tested to meet strict safety requirements. These include safety agency examination, approval, and compliance with established environmental standards.

Your attention to the following safety guidelines helps to ensure the continued, safe operation of your printer.

Operational Guidelines

- Do not remove any paper trays while the printer is printing.
- Do not open the doors when the printer is printing.

Safety

- Do not move the printer when it is printing.
- Keep hands, hair, neckties, and so on, away from the exit and feed rollers.
- Covers, which require tools for removal, protect the hazard areas within the printer. Do not remove the protective covers.

Hot Warning

The metallic surfaces in the fuser area are hot. Always use caution when removing paper jams from this area and avoid touching any metallic surfaces.

Ozone Release

This printer produces ozone during normal operation. The amount of ozone produced depends on copy volume. Ozone is heavier than air and is not produced in amounts large enough to harm anyone. Install the printer in a well-ventilated room.

For more information in the United States and Canada, go to www.xerox.com/environment. In other markets, contact your local Xerox representative or go to www.xerox.com/environment_europe.

Printer Location

- Place the printer on a level, solid, non-vibrating surface with adequate strength to hold its weight. To find the weight for your printer configuration, refer to [Physical Specifications](#).
- Do not block or cover the slots or openings on the printer. These openings are provided for ventilation and to prevent overheating of the printer.
- Place the printer in an area where there is adequate space for operation and servicing.
- Place the printer in a dust-free area.
- Do not store or operate the printer in an extremely hot, cold, or humid environment.
- Do not place the printer near a heat source.
- Do not place the printer in direct sunlight to avoid exposure to light-sensitive components.
- Do not place the printer where it is exposed directly to the cold air flow from an air conditioning system.
- Do not place the printer in locations that are susceptible to vibrations.
- For optimum performance, use the printer at the elevations specified in [Elevation](#).

Printer Supplies

- Use supplies that are designed for your printer. The use of unsuitable materials can cause poor performance and a possible safety hazard.
- Follow all warnings and instructions marked on, or supplied with the product, options, and supplies.
- Store all consumables in accordance with the instructions provided on the package or container.
- Keep all consumables away from the reach of children.
- Never throw toner, print cartridges, drum cartridges, or toner containers into an open flame.

- When handling cartridges, such as toner cartridges, avoid skin or eye contact with toner. Eye contact can cause irritation and inflammation. Do not attempt to disassemble the cartridge, which can increase the risk of skin or eye contact.

 **Caution**

Use of non-Xerox supplies is not recommended. The Xerox Warranty, Service Agreement, and Total Satisfaction Guarantee do not cover damage, malfunction, or degradation of performance caused by use of non-Xerox supplies, or the use of Xerox supplies not specified for this printer. The Total Satisfaction Guarantee is available in the United States and Canada. Coverage could vary outside these areas. For details, contact your Xerox representative.





Maintenance Safety













- Do not attempt to perform any maintenance procedure that is not described specifically in the documentation supplied with your printer.
- Do not use aerosol cleaners. Clean with a dry lint-free cloth only.
- Do not burn any consumables or routine maintenance items.
- For information on Xerox supplies recycling programs, go to www.xerox.com/gwa.













 **Warning**

Do not use aerosol cleaners. Aerosol cleaners can cause explosions or fires when used on electromechanical equipment.

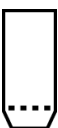









Printer Symbols

Symbol	Description
	Warning: Indicates a hazard that can cause serious injury or death if not avoided.
	Hot Warning: Hot surface on or in the printer. Use caution to avoid personal injury.
	Caution: Indicates a mandatory action to take to avoid damage to the property.
	Do not touch the part or area of the printer.

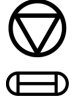
Symbol	Description
	Do not expose the drum cartridges to direct sunlight.
	Do not burn the toner cartridges.
	Do not burn the drum cartridges.
	Do not touch the part or area of the printer.
Symbol	Description
	Do not use paper attached with staples or any other form of binding clip.
	Do not use folded, creased, curled, or wrinkled paper.
	Do not load or use inkjet paper.
	Do not use transparencies or overhead projector sheets.
	Do not reload paper previously printed on or used.
	Add paper or media.
	Paper jam
	Lock
	Unlock

Symbol	Description
	Document
	Paper
	WLAN Wireless Local Area Network
	LAN Local Area Network
	USB Universal Serial Bus
	Postcard
	Load envelopes in the tray with the flaps closed and facing up.
	Load envelopes in the tray with the flaps open and facing up.
	Weight
	Data Transmission
	Paper Feeding Direction Indicator
	OK Button
	Print Menu Button

Safety

Symbol	Description
	Online Button
Symbol	Description
	Information Button
	Menu Button
	Back Button
	Power/Wake Button
	Cancel Job Button
	Left Direction Indicator
	Right Direction Indicator
	Up Direction Indicator
	Down Direction Indicator
	WPS Button (Wi-Fi Protected Setup)
	This item can be recycled. For details, refer to Recycling and Disposal .

Environmental, Health, and Safety Contact Information

For more information on Environment, Health, and Safety in relation to this Xerox product and supplies, contact the following customer help lines:

United States and Canada: 1-800-ASK-XEROX (1-800-275-9376)

Europe: +44 1707 353 434

For product safety information in the United States, go to www.xerox.com/environment.

For product safety information in Europe, go to www.xerox.com/environment_europe.

2

Features

Parts of the Printer

Front View

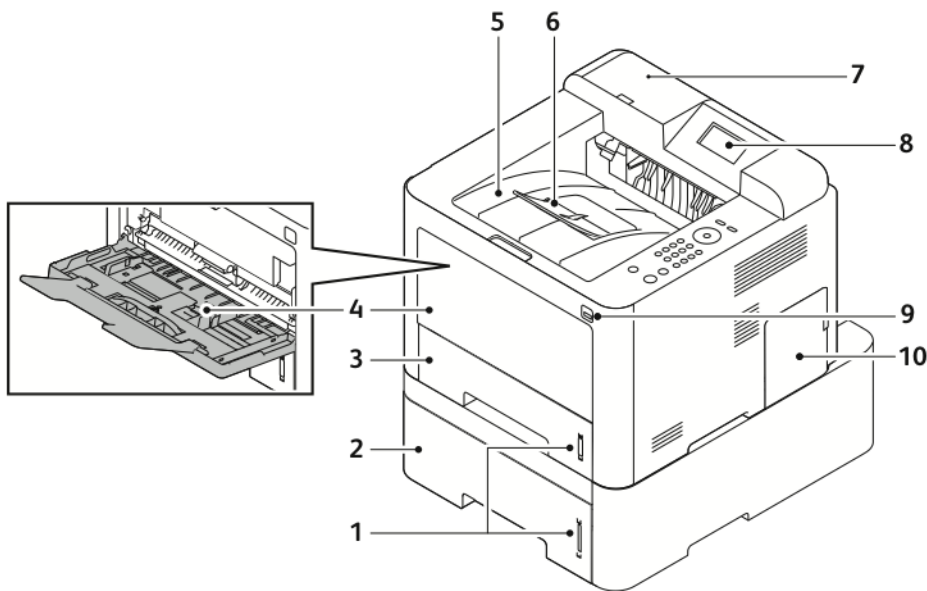

- | | |
|---|--|
| 1. Paper Level Indicator | 6. Output Tray Extension |
| 2. Optional Feeder Tray 2 with 550-Sheet Capacity | 7. Card Reader Bay for optional NFC Enablement Kit |
| 3. Tray 1 with 250-Sheet Capacity | 8. Control Panel Display |
| 4. Bypass Tray and Extension | 9. USB Port |
| 5. Output Tray | 10. Control Board Cover |

Rear View

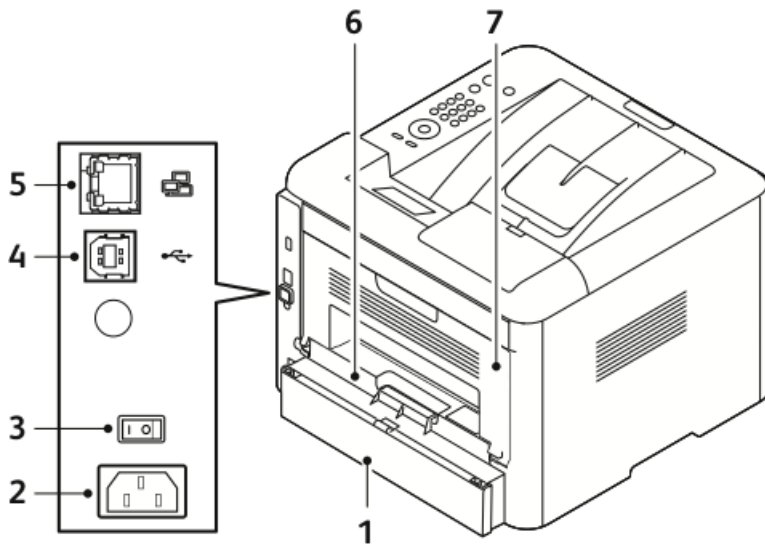

- 1. Tray 1 Rear Access Cover
- 2. Power Receptacle
- 3. Power Switch
- 4. USB Cable Port
- 5. Network Cable Port
- 6. Duplex Unit
- 7. Rear Door

Internal Components

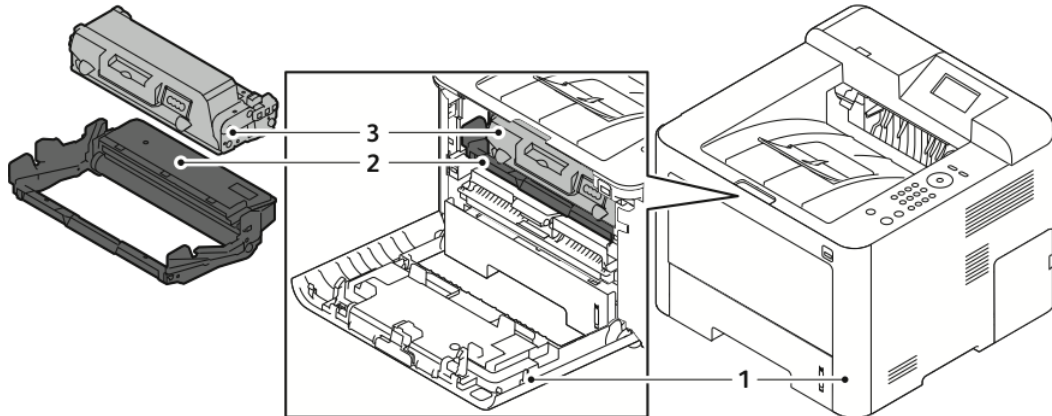

- 1. Front Cover
- 2. Drum Cartridge
- 3. Toner Cartridge

Control Panel

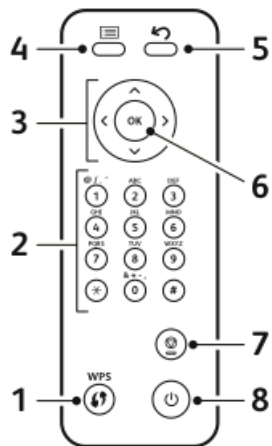

No.	Description	No.	Description
1	WPS (Wi-Fi Protected Services) Button: Used for wireless network connectivity.	5	Back Button: Used to go back one level in the menu.
2	Alphanumeric Keypad	6	OK Button: Confirms the selection on the control panel display.
3	Arrow Buttons: The up/down and left/right arrows are used to scroll through the options available in the selected menu, as shown on the control panel display, and to increase and decrease the values.	7	Cancel Button
4	Menu Button: Enters Menu Mode and lets you access options and settings.	8	Power On/Off Button

Information Pages

Your printer has a set of information pages that you can access from the printer control panel.

Accessing the Information Pages

1. At the printer control panel, press the **Menu** button. If necessary, allow a moment for the machine to warm up.
2. Press the **Menu** button again.
A list of menu items appear.
3. Press the **Up/Down** arrow button, and select **Information**.
4. Press the **Right** arrow button.
5. Press the **Up/Down** arrow button, and select **Information**.
A list of Information pages appear.
6. Press the **Up/Down** arrow button, and select an information page to print.
7. To select an information page, press the **Right** arrow button, and then select the **OK** button.

Configuration Report

The Configuration Report provides product information including installed options, network settings, port setup, tray information, and more.

To print the Configuration Report, refer to the *System Administrator Guide* at www.xerox.com/office/3330docs.

Power Saver Mode

Power Saver mode reduces power consumption when the printer is left idle for a specified period.

Power Saver Levels

There are two levels of Power Saver mode.

- **Low Power Save:** After a specified period of inactivity, the control panel display dims and the printer operates on reduced power consumption.
- **Very Low Power Save:** After a specified period of inactivity, the control panel display turns off and the printer enters standby mode.

Setting the Power Saver Mode Timers at the Control Panel

For details, refer to the *System Administrator Guide* at www.xerox.com/office/3330docs

Exiting Power Saver Mode

The printer exits Power Saver mode automatically when any of the following events occur.

- You press a button on the control panel.
- The printer receives data from a connected device.
- You open any door or cover on the printer.

Administration Features

For details, refer to the *System Administrator Guide* at www.xerox.com/office/3330docs.

Xerox® CentreWare® Internet Services

Xerox® CentreWare® Internet Services is the administration and configuration software installed on the embedded Web server in the printer. It allows you to configure and administer the printer from a Web browser.

Xerox® CentreWare® Internet Services requires:

- A TCP/IP connection between the printer and the network in Windows, Macintosh, UNIX, or Linux environments.
- TCP/IP and HTTP enabled in the printer.
- A network-connected computer with a Web browser that supports JavaScript.

Accessing Xerox® CentreWare® Internet Services

1. At your computer, open a Web browser.
2. In the address field, type the IP address of the printer.
3. Press **Enter** or **Return**.

Locating the IP Address of the Printer

To install print drivers for a network-connected printer, you need the IP address of your printer. You also need the IP address to access and configure any printer settings in Xerox® CentreWare® Internet Services.

You can view the IP address of your printer on the control panel display.

1. At the printer control panel, press the **Menu** button.
2. Press the **Up/Down** arrow button, and select **Information**.
3. Press the **Right** arrow button.
4. Press the **Down** arrow button, and select **About this Printer**.
5. Press the **Right** arrow button.
6. Press the **Down** arrow button, and select **TCP/IPv4 Address**.
The screen automatically scrolls right to left, showing the IP address.

Maintenance Assistant

Your printer includes a built-in diagnostic capability allowing you to send diagnostic information directly to Xerox. Maintenance Assistant is a remote diagnostic tool that offers a fast way to resolve potential issues, receive assistance, and automate the troubleshooting or repair process.

Enabling Maintenance Assistant

Before you begin: If your network uses a proxy server, configure the Proxy Server settings of the printer to ensure that the printer can connect to the Internet.

1. From the Printer Status window, click **Help > Xerox® CentreWare® Internet Services**.

2. From Xerox® CentreWare® Internet Services, click **Status > SMart eSolutions**.
3. From Smart eSolutions, click **Maintenance Assistant**.
4. To send status information to Xerox, click **Start an Online Troubleshooting Session at www.Xerox.com**.
5. After the data is sent, your browser is redirected to www.xerox.com to start your online troubleshooting session.

More Information

You can obtain more information about your printer from these sources:

Resource	Location
<i>Installation Guide</i>	Packaged with the printer.
Other documentation for your printer	www.xerox.com/office/3330docs
Technical support information for your printer, including online technical support, Online Support Assistant, and driver downloads.	www.xerox.com/office/3330support
Information about menus or error messages	Press the control panel Help (?) button.
Information Pages	Print from the control panel, or from Xerox® CentreWare® Internet Services, click Properties > Services > Printing > Reports .
Xerox® CentreWare® Internet Services documentation	From Xerox® CentreWare® Internet Services, click Help .
Order supplies for your printer	www.xerox.com/office/3330supplies
A resource for tools and information, including interactive tutorials, printing templates, helpful tips, and customized features to meet your individual needs.	www.xerox.com/office/businessresourcecenter
Local sales and support center	www.xerox.com/office/worldcontacts
Printer registration	www.xerox.com/office/register
Xerox® Direct online store	www.direct.xerox.com/

3

Installation and Setup

See also:

Installation Guide packaged with your printer.

System Administrator Guide at www.xerox.com/office/3330docs.

Installation and Setup Overview

Before printing, ensure that your computer and the printer are plugged in, turned on, and connected. Configure the initial settings of the printer, then install the driver software and utilities on your computer.

You can connect to your printer directly from your computer using USB, or connect to a network using an Ethernet cable or wireless connection. Hardware and cabling requirements vary for the different connection methods. Routers, network hubs, network switches, modems, Ethernet cables, and USB cables are not included with your printer and must be purchased separately. Xerox recommends an Ethernet connection because, typically, it is faster than a USB connection, and it provides access to Xerox® CentreWare® Internet Services.

Note

If the Software and Documentation disc is not available, you can download the latest drivers from www.xerox.com/office/3330drivers.

Related Topics:

[Selecting a Location for the Printer](#)

[Selecting a Connection Method](#)

[Connecting the Printer to the Network](#)

[Configuring Network Settings](#)

[Installing the Software](#)

Selecting a Location for the Printer

Note

Sudden temperature fluctuations can affect print quality. Rapid heating of a cold room can cause condensation inside the printer, directly interfering with image transfer.

- Select a dust-free area with temperatures from 10–30°C (50–90°F), and relative humidity 20–80 %
- Place the printer on a level, solid, non-vibrating surface with adequate strength for the weight of the printer. The printer must be horizontal with all four feet in solid contact with the surface. To find the weight for your printer configuration, see [Physical Specifications](#).
- Select a location with adequate clearance to access supplies and to provide proper ventilation. To find the clearance requirements for your printer, see [Clearance Requirements for Standard Configuration](#).
- After positioning the printer, you are ready to connect it to the power source and computer or network.

Connecting the Printer

Selecting a Connection Method

The printer can be connected to your computer using a USB cable or an Ethernet cable. The method you select depends on how your computer is connected to the network. A USB connection is a direct connection and is the easiest to set up. An Ethernet connection is used for networking. If you are using a network connection, it is important to understand how your computer is connected to the network. For details, refer to [About TCP/IP and IP Addresses](#).

Note

- Not all options listed are supported on all printers. Some options apply only to a specific printer model, configuration, operating system, or driver type.
- Hardware and cabling requirements vary for the different connection methods. Routers, network hubs, network switches, modems, Ethernet cables, and USB cables are not included with your printer and must be purchased separately.

Network

If your computer is connected to an office network or home network, use an Ethernet cable to connect the printer to a network port. Ethernet networks can support many computers, printers, and devices simultaneously. In most cases, an Ethernet connection is faster than USB and provides direct access to printer settings using Xerox® CentreWare® Internet Services.

Wireless Network

If your network includes a wireless router or wireless access point, you can connect the printer to the network with a wireless connection. A wireless network connection provides the same access and services as a wired connection provides. A wireless network connection is typically faster than USB and allows direct access to the printer settings when using Xerox® CentreWare® Internet Services.

USB

If you connect the printer to one computer and do not have a network, use a USB connection. A USB connection offers fast data speeds, but typically not as fast as an Ethernet connection. In addition, a USB connection does not provide access to Xerox® CentreWare® Internet Services.

Connecting the Printer to the Network

Use a Category 5 or higher Ethernet cable to connect the printer to the network. An Ethernet network is used for one or more computers and supports many printers and systems simultaneously. An Ethernet connection provides direct access to printer settings using Xerox® CentreWare® Internet Services.

To connect the printer:

1. Connect the power cord to the printer, and plug the cord into an electrical outlet.
2. Connect one end of a Category 5 or higher Ethernet cable to the Ethernet port on the printer. Connect the other end of the Ethernet cable to a correctly configured network port on a hub or router.
3. Turn on the printer.

For details on configuring network settings, refer to the *System Administrator Guide* at www.xerox.com/office/3330docs.

Connecting to a Computer Using USB

To connect using USB, you need Windows 7, Windows 8 or later, Windows Server 2008 or later, or Macintosh OS X version 10.9 or later.

To connect the printer to the computer using a USB cable:

1. Connect the B end of a standard A/B USB 2.0 cable to the USB Port on the left side of the printer.
2. Connect the A end of the USB cable to the USB port on the computer.
3. If the Windows Found New Hardware Wizard appears, select **Cancel**.
4. Install the print drivers. For details, refer to [Installing the Software](#).

Turning On/Off the Printer

Before turning on the printer, ensure that the power cord is plugged into the printer and wall outlet, and that the power switch is in the off position.

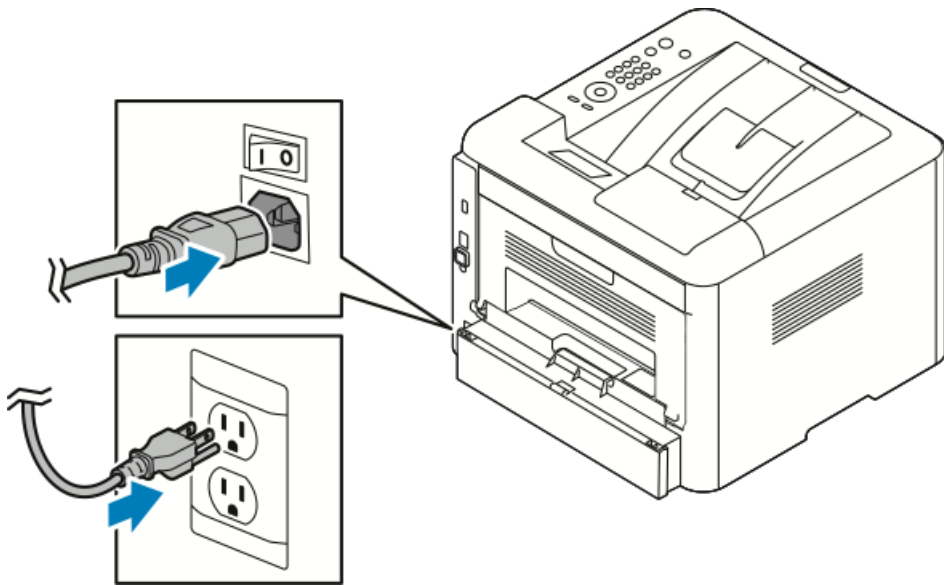

The printer has a *power Down* button on the control panel display and a *power switch* on the back-left side.

- The *power down* button on the control panel display initiates an orderly shutdown of the printer electronic components.
 - The *power switch* on the side of the printer controls the main power to the printer.
1. To turn on the printer, press the power switch to the **On** position.

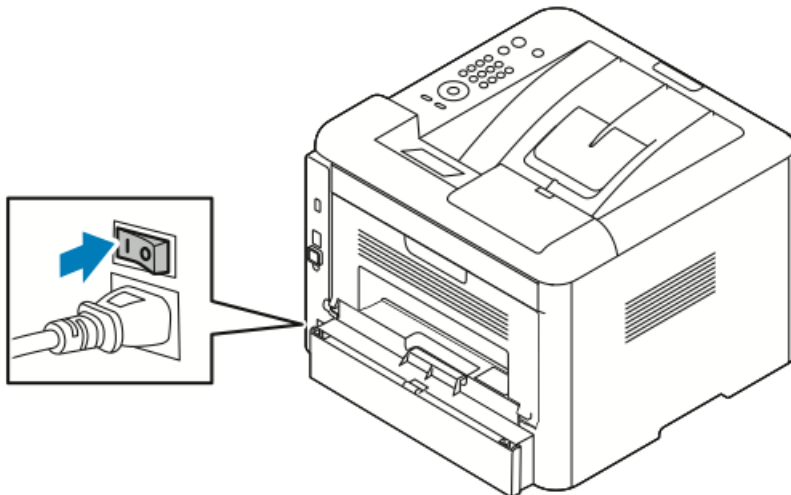

If the power switch is on, but the printer is powered off, the printer was turned off using the control panel. To switch on the printer, press the power switch to the **Off** position and then to the **On** position.

2. To turn off the printer:

! **Caution**

- To prevent a printer malfunction, perform the control panel shutdown first.
 - Do not plug or unplug the power cord while the printer is powered on.
- a) At the printer control panel, press the **Power Saver** button.

b) Touch **Power Down**.

Note

When all of the control panel lights are off, the printer power-off sequence is complete. Turning the power switch off is optional.

Configuring Network Settings

About TCP/IP and IP Addresses

Computers and printers primarily use TCP/IP protocols to communicate over an Ethernet network. Generally, Macintosh computers use either TCP/IP or the Bonjour protocol to communicate with a network printer. For Macintosh OS X systems, TCP/IP is preferred. Unlike TCP/IP, however, Bonjour does not require printers or computers to have IP addresses.

With TCP/IP protocols, each printer and computer must have a unique IP address. Many networks and cable and DSL routers have a Dynamic Host Configuration Protocol (DHCP) server. A DHCP server automatically assigns an IP address to every computer and printer on the network that is configured to use DHCP.

If you use a cable or DSL router, for information on IP addressing, refer to the documentation for your router.

Installing the Software

Before you install driver software, verify that the printer is plugged in, turned on, connected correctly, and has a valid IP address. If you cannot find the IP address, see [Locating the IP Address of the Printer](#).

If the *Software and Documentation* disc is not available, download the latest drivers from www.xerox.com/office/3330drivers.

Operating System Requirements

Windows Vista, Windows 7, Windows 8, Windows Server2008, WindowsServer2008 R2, and Windows Server 2012.

- Macintosh OS X version 10.9 and later
- UNIX and Linux: Your printer supports connection to various UNIX platforms through the network interface. For details, see www.xerox.com/office/3330drivers.

Installing Drivers and Utilities for Windows

To access all the features of your printer, install the Xerox® print driver and the Xerox® scan driver.

To install the print and scan driver software:

1. Insert the *Software and Documentation* disc into the appropriate drive on your computer. The installer starts automatically.

If the installer does not start automatically, navigate to the drive, and double-click the **Setup.exe** installer file.

2. To change the language, click **Language**.
3. Select your language, then click **OK**.
4. Click **Install Drivers > Install Print and Scan Drivers**.
5. To accept the license agreement, click **I Agree**.
6. From the list of discovered printers, select your printer, then click **Next**.
7. If your printer does not appear in the list of discovered printers, click **Extended Search**.
8. If your printer still does not appear in the list of discovered printers, and you know the IP address:
 - a) Click the **Network Printer** icon at the top of the window.
 - b) Enter the IP address or the DNS name of the printer.
 - c) Click **Search**.
 - d) From the list of discovered printers, select your printer, then click **Next**.
9. If the printer still does not appear in the list of discovered printers, and you do not know the IP address:
 - a) Click **Advanced Search**.
 - b) If you know the gateway address and subnet mask, click the top button and enter the addresses into the Gateway and Subnet Mask fields.
 - c) If you know the address of another printer on the same subnet, click the middle button and enter the address in the IP Address field.
 - d) Click **Search**.
 - e) From the list of discovered printers, select your printer, then click **Next**.

Note

When the printer appears in the Discovered Printers window, it displays the IP address. Record the IP address for future use.

10. Select the desired driver.
11. Click **Install**.
12. If the installer prompts you for the IP address, enter the IP address of the printer.
13. If the installer prompts you to restart your computer, click **Restart** to complete the installation of the drivers.
14. To complete the installation, click **Finish**.

Installing Print Drivers for Macintosh OS X Version 10.9 and Later

Install the Xerox print driver to access all features of your printer.

To install the print driver software:

1. Insert the *Software and Documentation* disc into the appropriate drive on your computer.
2. To view the **.dmg** file for your printer, double-click the disc icon.
3. Open the **.dmg** file, then navigate to the appropriate installer file for your operating system.
4. To begin installation, open the Installer package file.
5. To acknowledge the warning and introductory messages, click **Continue**. Click **Continue** again.
6. To accept the license agreement, click **Continue**, then click **Agree**.
7. To accept the current installation location, click **Install**, or select another location for the installation files, then click **Install**.
8. Enter your password, then click **Install Software**.
9. Select your printer in the list of discovered printers, then click **Continue**. If your printer does not appear in the list of discovered printers:
 - a) Click the **Network Printer** icon.
 - b) Type the IP address of your printer, then click **Continue**.
 - c) Select your printer in the list of discovered printers, then click **Continue**.
10. To accept the print queue message, click **Continue**.
11. To accept the installation success message, click **Close**.
12. To verify that the print driver recognizes the installed options:
 - a) From the Apple menu, click **System Preferences > Printers and Scanners**.
 - b) Select the printer from the list, then click **Options & Supplies**.
 - c) Click **Options**.
 - d) Confirm that all of the options installed on the printer appear correct.
 - e) If you change settings, click **OK**, close the window, then exit System Preferences.

Installing the Print Drivers for UNIX and Linux

To install the UNIX print drivers on your computer, root or superuser privileges are required.

This procedure requires an Internet connection.

To install Linux drivers, perform the following steps, then select **Linux** instead of UNIX for the operating system and package.

To install the print driver software:

1. At the printer, verify that the TCP/IP protocol is enabled and the network cable is installed.
2. At the printer control panel, for the IP address, do the following:
 - a) Allow the printer to set up a DHCP address.
 - b) Print the configuration page and keep it for reference.
3. At your computer, do the following:
 - a) From the print driver website for your printer, select your printer model.
 - b) From the Operating System menu, select **UNIX**, then click **Go**.
 - c) Select the appropriate package for your operating system.
 - d) To begin downloading, click the **Start** button.
4. In the notes below the driver package that you selected, click the **Installation Guide** link, then follow the installation instructions.

Other Drivers

The following drivers are available for download at www.xerox.com/office/3330drivers.

- The Xerox® Global Print Driver works with any printer on your network, including those printers made by other manufacturers. It configures itself for your individual printer at installation.
- The Xerox® Mobile Express Driver works with any printer available that supports standard PostScript. It configures itself for the printer you select every time you print. If you travel frequently to the same sites, you can save your favorite printers in that location and the driver saves your settings.

Installing the Printer as a Web Service on Devices

Web Services on Devices (WSD) allow a client to discover and access a remote device and its associated services across a network. WSD supports device discovery, control, and use.

Installing a WSD Printer Using the Add Device Wizard

1. At your computer, click **Start**, then select **Devices and Printers**.

2. To launch the Add Device Wizard, click **Add a Device**.
3. In the list of available devices, select the one you want to use, then click **Next**.

Note

If the printer you want to use does not appear in the list, click the **Cancel** button. Add the WSD printer manually using the Add Printer Wizard; for details, refer to [Installing a WSD Printer Manually Using the Add Printer Wizard](#).

4. Click **Close**.

Installing a WSD Printer Manually Using the Add Printer Wizard

1. At your computer, click **Start**, then select **Devices and Printers**.
2. To launch the Add Printer Wizard, click **Add a Printer**.
3. Click **Add a network, wireless, or Bluetooth printer**.
4. In the list of available devices, select the one you want to use, then click **Next**.
5. If the printer that you want does not appear in the list, click **The printer that I want is not listed**.
6. Select **Add a printer using a TCP/IP address or hostname**, then click **Next**.
7. For the Device type field, select **Web Services Device**.
8. In the Hostname or IP address field, enter the printer IP address. Click **Next**.
9. Select an option for sharing the printer with others in your network.
10. To identify the printer for sharing, enter a share name, location, and comments to identify the printer. Click **Next**.
11. To set the printer as the default, select an option. To test the connection, click **Print a Test Page**.
12. Click **Finish**.

AirPrint, Mopria, Google Cloud Print, and NFC

The following allow you to print without requiring a print driver:

AirPrint

Use AirPrint to print from a wired or wireless device directly without using a print driver. AirPrint is a software feature that allows you to print from wired or wireless Apple iOS-based mobile devices and Mac OS-based devices without the need to install a print driver. AirPrint-enabled printers allow you to print or fax directly from a Mac, an iPhone, iPad, or iPod touch.

Mopria

Mopria is a software feature that enables users to print from mobile devices without requiring a print driver. You can use Mopria to print from your mobile device to Mopria-enabled printers.

Google Cloud Print

Google Cloud Print allows you to print documents from an Internet-connected device without using a print driver. Documents stored in the cloud, a personal computer, tablet, or smartphone can be sent to the printer from anywhere.

NFC (Near Field Communication)

Near field communication (NFC) is a technology that enables devices to communicate when they are within 10 centimeters of each other. You can use NFC to obtain the network interface to establish a TCP/IP connection between your device and the printer.

For more information, refer to the *System Administrator Guide*:

- www.xerox.com/office/WC3335docs
- www.xerox.com/office/WC3345docs

4

Paper and Media

Supported Paper

Your printer is designed to use various paper and other media types. To ensure the best print quality and to avoid jams, follow the guidelines in this section.

For best results, use Xerox paper and media recommended for your printer.

Ordering Paper

To order paper or other media, contact your local reseller or visit www.xerox.com/office/3330supplies.

General Paper Loading Guidelines

- Fan paper before loading it in the paper tray.
- Do not overfill the paper trays. Do not load paper above the maximum fill line in the tray.
- Adjust the paper guides to fit the paper size.
- If excessive jams occur, use paper or other approved media from a new package.
- Do not print on label media after a label has been removed from a sheet.
- Use only paper envelopes.
- Print envelopes 1-sided only.

Paper That Can Damage Your Printer

Some paper and other media types can cause poor output quality, increased paper jams, or damage your printer. Do not use the following:

- Rough or porous paper
- Inkjet paper
- Non-laser glossy or coated paper
- Paper that has been photocopied
- Paper that has been folded or wrinkled

Paper and Media

- Paper with cutouts or perforations
- Stapled paper
- Envelopes with windows, metal clasps, side seams, or adhesives with release strips
- Padded envelopes
- Plastic media

Caution

The Xerox® Warranty, Service Agreement, or Xerox® Total Satisfaction Guarantee does not cover damage caused by using unsupported paper or specialty media. The Xerox® Total Satisfaction Guarantee is available in the United States and Canada. Coverage could vary outside these areas. For details, please contact your local Xerox representative.

Paper Storage Guidelines

Storing paper and other media properly contributes to optimum print quality.

- Store paper in dark, cool, relatively dry locations. Most paper is susceptible to damage from ultraviolet and visible light. Ultraviolet light, from the sun and fluorescent bulbs, is particularly damaging to paper.
- Reduce the exposure of paper to strong lights for long periods of time.
- Maintain constant temperatures and relative humidity.
- Avoid storing paper in attics, kitchens, garages, or basements. These spaces are more likely to collect moisture.
- Store paper flat, either on pallets, cartons, shelves, or in cabinets.
- Avoid food or drinks in the area where paper is stored or handled.
- Do not open sealed packages of paper until you are ready to load the paper into the printer. Leave stored paper in the original packaging. The paper wrapper protects the paper from moisture loss or gain.
- Some special media is packaged inside resealable plastic bags. Store the media inside the bag until you are ready to use it. Keep unused media in the bag and reseal it for protection.

Supported Paper Types and Weights

Trays	Paper Types	Weights
Bypass and Trays 1 and 2	Plain Letterhead Pre-printed Hole-Punched Lightweight Heavyweight Cardstock Bond Recycled Archival	70–85 g/m ² 70–85 g/m ² 70–85 g/m ² 70–85 g/m ² 60–70 g/m ² 85–105 g/m ² 106–163 g/m ² 105–120 g/m ² 60–85 g/m ² Not Applicable
Bypass Tray and Tray 1 only	Transparency	Not Applicable

Trays	Paper Types	Weights
Bypass Tray only	Labels Envelope Custom	120–150 g/m ² 75–90 g/m ² 60–220 g/m ²

Supported Standard Paper Sizes

Tray	European Standard Sizes	North American Standard Sizes
Bypass and Trays 1 and 2	A4 (210 x 297 mm, 8.3 x 11.7 in.) A5 (148 x 210 mm, 5.8 x 8.3 in.) JIS B5 (182 x 257 mm, 7.2 x 10.1 in.) ISO B5 (176 x 250 mm, 6.9 x 9.8 in.) A6 (105 x 148 mm, 4.1 x 5.8 in.)	Letter (216 x 279 mm, 8.5 x 11 in.) Legal (216 x 356 mm, 8.5 x 14 in.) Oficio (216 x 343 mm, 8.5 x 13.5 in.) Folio (216 x 330 mm, 8.5 x 13 in.) Executive (184 x 267 mm, 7.25 x 10.5 in.) Statement (140 x 216 mm, 5.5 x 8.5 in.)
Bypass Tray only	C5 envelope (162 x 229 mm, 6.4 x 9 in.) C6 envelope (114 x 162 mm, 4.5 x 6.38 in.) DL envelope (110 x 220 mm, 4.33 x 8.66 in.) Index Card (76.2 x 127 mm, 3 x 5 in.) Postcard (100 x 148 mm, 3.94 x 5.83 in.)	Postcard (102 x 152 mm, 4 x 6 in.) No. 10 envelope (241 x 105 mm, 4.1 x 9.5 in.) No. 9 envelope (114 x 162 mm, 4.5 x 6.38 in.) Monarch envelope (98 x 190 mm, 3.9 x 7.5 in.) Index Card (76.2 x 127 mm, 3 x 5 in.)

Supported Custom Paper Sizes

Tray	Width	Length
Bypass Tray	98–216 mm (3.9–8.5 in.)	148–356 mm (5.8–14 in.)
Trays 1 and 2	105–216 mm (4.1–8.5 in.)	148–356 mm (5.8–14 in.)

Supported Paper Types and Weights for Automatic 2-Sided Printing

Paper Types	Weights
Lightweight	60–70 g/m ²
Recycled	60–85 g/m ²
Plain Letterhead Hole-Punched Pre-printed	70–85 g/m ²

Paper and Media

Paper Types	Weights
Heavyweight	86–105 g/m ²
Bond	105–120 g/m ²

Supported Standard Paper Sizes for Automatic 2-Sided Printing

European Standard Sizes	North American Standard Sizes
A4 (210 x 297 mm, 8.3 x 11.7 in.)	Letter (216 x 279 mm, 8.5 x 11 in.) Legal (216 x 356 mm, 8.5 x 14 in.) Oficio (216 x 343 mm, 8.5 x 13.5 in.) Folio (216 x 330 mm, 8.5 x 13 in.) Executive (184 x 267 mm, 7.25 x 10.5 in.)

Supported Custom Paper Sizes for Automatic 2-Sided Printing

Source	Media Types	Sizes	Thickness
Tray 1 or 2	Plain, Lightweight, Heavyweight, Bond, Cardstock, Recycled, Archive	A4, Letter, Legal, Executive, Folio, Oficio, ISO B5, JIS B5, A5, A6	60–163 g (16–43 lb.)
Bypass Tray	Plain, Lightweight, Heavyweight, Bond, Cardstock, Cotton, Colored, Pre-Printed, Recycled, Archive, Transparency, Label	A4, Letter, Legal, Executive, Folio, Oficio, ISO B5, JIS B5, A5, A6, 3"x5"	60~220 g.(16–58 lb.)
	Envelope	Monarch, No.10, DL, C5, C6	
	Cardstock	International Post Card	
	Custom	Odd size: min 75 mm width x 125 mm length	
Duplex	Plain, Lightweight, Heavyweight, Bond, Recycled	A4, Letter, Legal, Folio, Oficio	60~120 g (16–32 lb.)

Loading Paper

Loading Paper in the Bypass Tray

To load paper in the bypass tray:

1. Open the bypass tray.

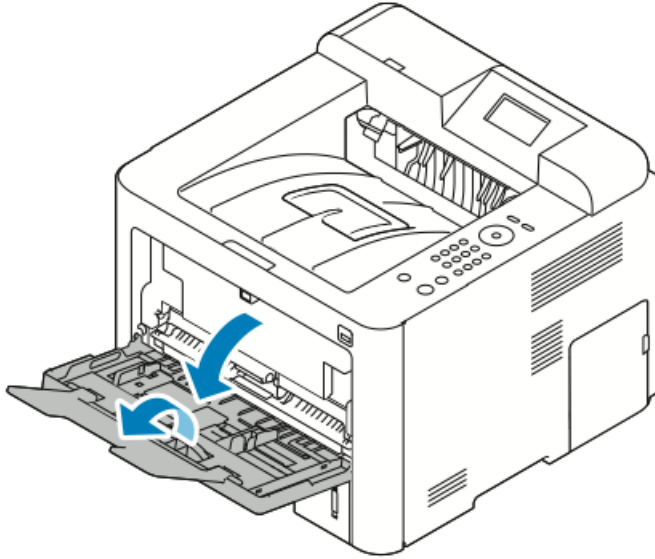

If the bypass tray is loaded with paper already, remove any paper that is a different size or type.

2. Move the width guides to the edges of the tray.
3. Flex the sheets back and forth and fan them, then align the edges of the stack on a level surface. This procedure separates any sheets that are stuck together and reduces the possibility of jams.

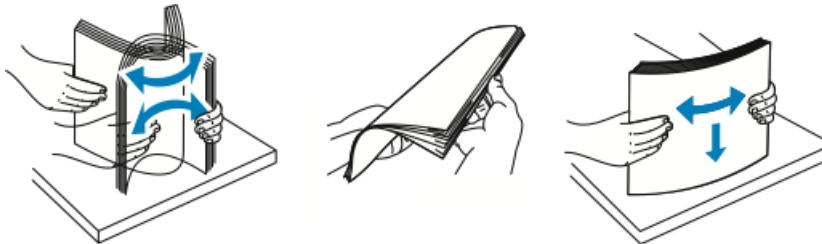

Note

To avoid jams and misfeeds, do not remove paper from its packaging until you are ready to use it.

4. Load the paper in the tray, and adjust the width guides until they touch the edges of the paper.

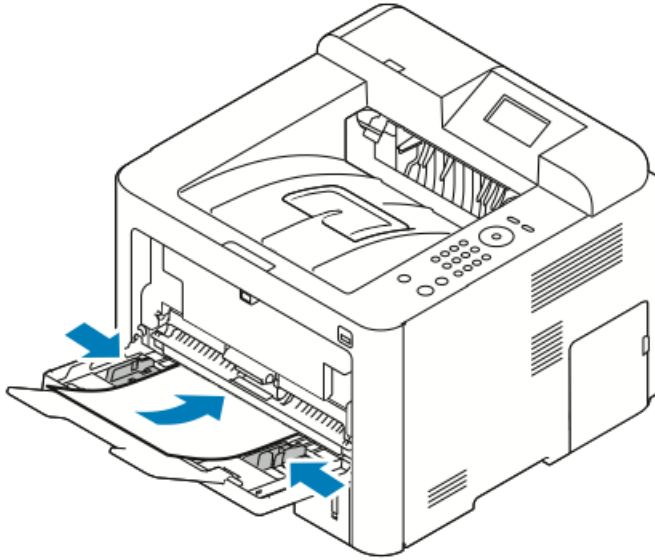

- Load hole-punched paper with the holes toward the left side of the printer.
- For 1-sided and 2-sided printing, to load letterhead or pre-printed paper, place letterhead face up with the top edge going into the printer first.

Note

Do not load paper above the maximum fill line. Overfilling the tray can cause the printer to jam.

5. If the control panel Paper Settings screen prompts you, verify the paper size, type, and color.
6. When finished, touch **Confirm**.

Loading Paper in Tray 1 and Optional Tray 2

Note

The following procedure applies to both tray 1 or tray 2.

1. Pull out the tray.

- For tray 1, pull out and remove the tray.

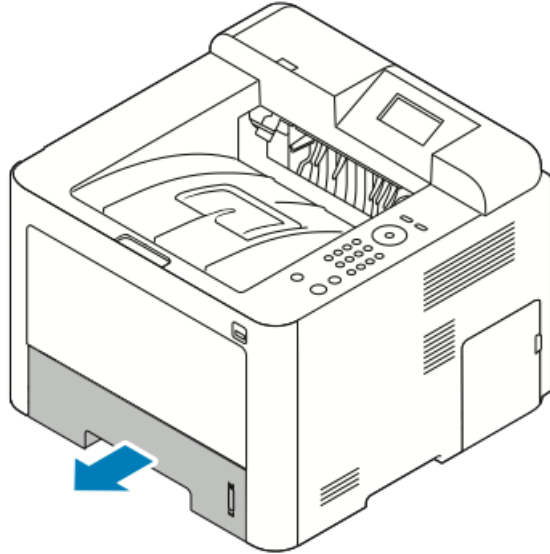

- For tray 2, remove the tray by pulling it out until it stops, lifting the front of the tray slightly, and then pulling it out.

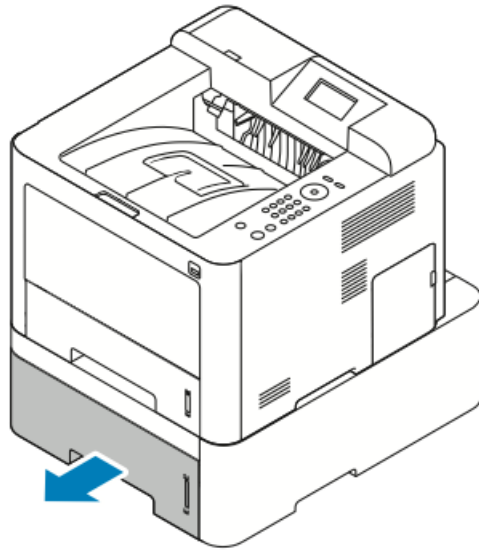

2. Move the length and width guides out:

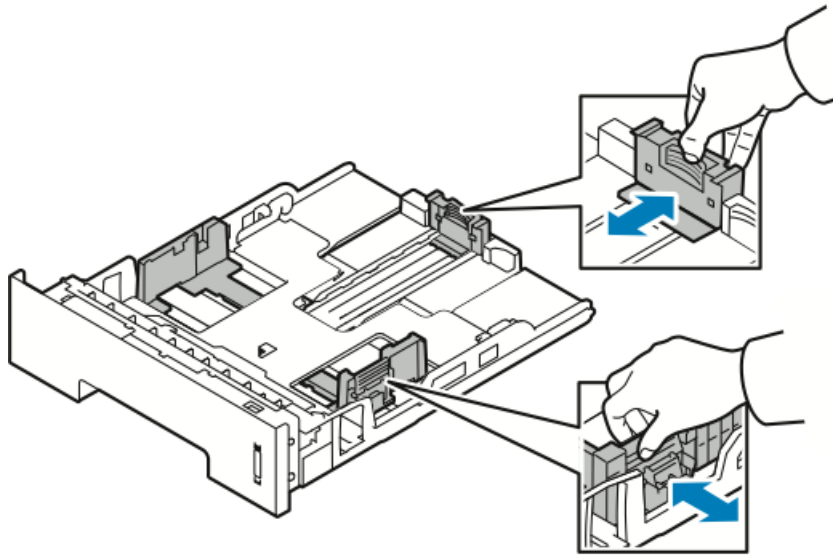

- a) Pinch the guide lever on each guide.
 - b) Slide the guides outward until they stop.
 - c) Release the levers.
3. Flex the sheets back and forth and fan them, then align the edges of the stack on a level surface. This procedure separates any sheets that are stuck together and reduces the possibility of jams.

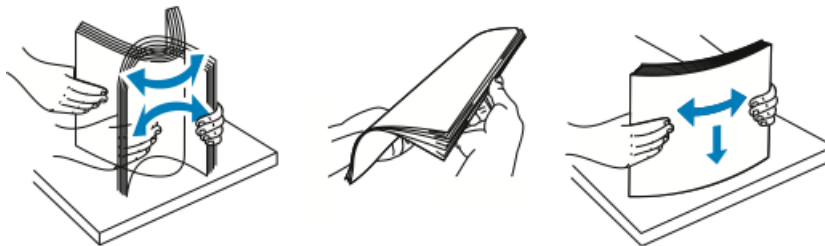

4. Load the paper into the tray, and adjust the paper guides in the tray to match the size of the paper.

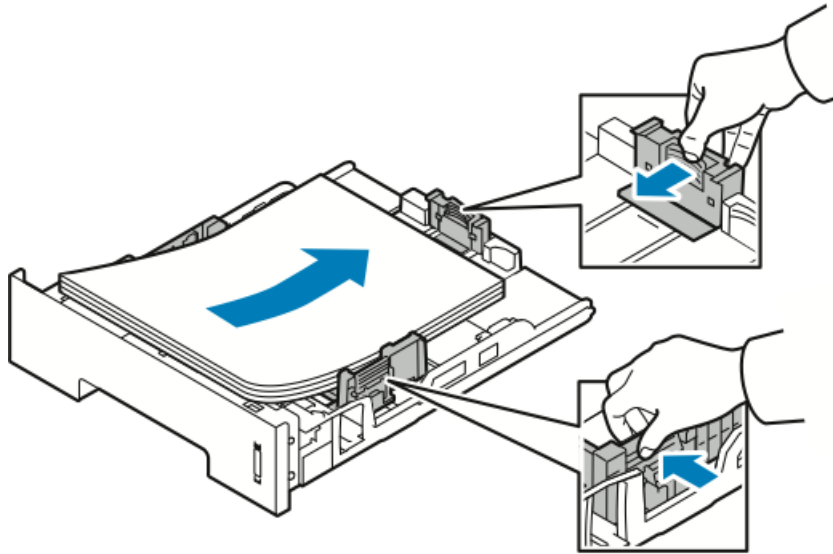

- Load paper into the tray with the print side face down.
 - Load hole-punched paper with the holes toward the right of the printer.
 - Do not load paper above the maximum fill line. Overfilling can cause paper jams.
5. Slide the tray into the printer and push it in all the way.
 6. If the control panel Paper Settings screen prompts you, verify the paper size, type, and color.
 7. When finished, touch **Confirm**.

Setting Paper Size and Type

After loading paper in the paper tray, set the paper size and type using the control panel. For computer printing, select the paper size and type in the application program you use on your computer.

Note

The settings made from the printer driver on your computer override the settings on the control panel.

After closing the paper tray, the Paper Size and Type settings are automatically displayed. If correct, use the settings displayed or use the following procedures to change the settings for the the size and type of paper loaded.

Setting the Paper Size

1. Press **Menu** on the control panel.
2. Press the **Up/Down** arrow buttons, and select **Tray Paper Settings**.
3. Press the **Right** arrow button.
4. Press the **Up/Down** arrow buttons, and select the required tray.

5. Press the **Right** arrow button.
6. Press the **OK** button to accept current setup, or press the **Down** arrow button to change the setup.
7. Press the **Right** arrow button.
8. With Paper Size selected, press the **Right** arrow button.
9. Press the **Up/Down** arrow buttons, select the paper size.
10. Press the **OK** button to save changes.

If you want to use special sized paper, select a custom paper size in the Printer Driver.

Setting the Paper Type

1. Press **Menu** on the control panel.
2. Press the **Up/Down** arrow buttons, and select **Tray Paper Settings**.
3. Press the **Right** arrow button.
4. Press the **Up/Down** arrow buttons, and select the required tray.
5. Press the **Right** arrow button.
6. Press the **OK** button to accept current setup, or press the **Down** arrow button to change the setup.
7. Press the **Right** arrow button.
8. Press the **Up/Down** arrow buttons, and select **Paper Type**.
9. Press the **Right** arrow button.
10. Press the **Up/Down** arrow buttons, and select the paper type.
11. Press the **OK** button to save changes.

Printing on Special Paper

To order paper, transparencies, or other media, contact your local reseller or go to www.xerox.com/office/3330supplies.

Envelopes

Note

You can **ONLY** print envelopes from the bypass tray. For details, see [Supported Standard Paper Sizes](#).

Guidelines for Printing Envelopes

- Print quality depends on the quality and construction of the envelopes. Try another envelope brand if you do not get desired results.
- Maintain constant temperatures and relative humidity.
- Store unused envelopes in their packaging to avoid excess moisture and dryness which can affect print quality and cause wrinkling. Excessive moisture can cause the envelopes to seal before or during printing.
- Before loading envelopes into the tray, remove air bubbles by setting a heavy book on top of them.
- In the print driver software, select **Envelope** as the paper type.
- Do not use padded envelopes. Use envelopes that lie flat on a surface.
- Do not use envelopes with heat-activated glue.
- Do not use envelopes with press-and-seal flaps.
- Use only paper envelopes.
- Do not use envelopes with windows or metal clasps.

Loading Envelopes in the Bypass Tray

1. Open the bypass tray.

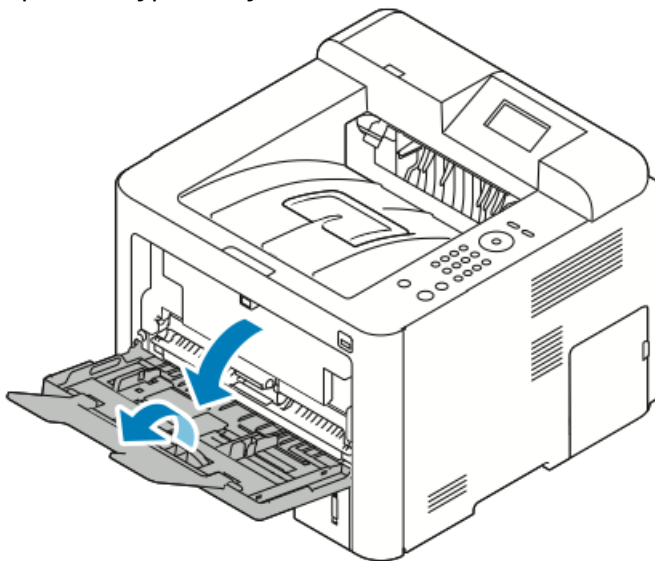

2. Move the width guides to the edges of the tray.

If you do not load envelopes in the bypass tray right after they have been removed from the packaging, they can bulge. Flatten them to avoid jams.



3. To load envelopes, place the envelopes with the print side up, flaps closed and down, and the flap of the envelope to the left.

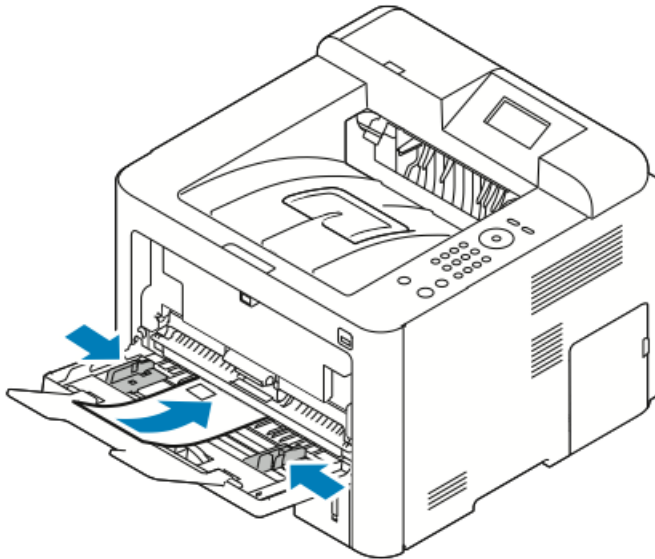

4. Adjust the guides until they touch the edges of the paper.
5. If the control panel Paper Settings screen prompts you, verify the paper size, type, and color.
6. When finished, touch **Confirm**.

Labels

Note

You can print labels *only* from the Bypass Tray.

Guidelines for Printing Labels

⚠ Caution

Do not use any sheet where labels are missing, curled, or pulled away from the backing sheet. It could damage the printer.

- Use labels designed for laser printing.
- Do not use vinyl labels.
- Do not feed a sheet of labels through the printer more than once.
- Do not use dry gum labels.
- Print only on one side of the sheet of labels. Use full sheet labels only.
- Store unused labels flat in their original packaging. Leave the sheets of labels inside the original packaging until ready to use. Return any unused sheets of labels to the original packaging and reseal it.
- Do not store labels in extremely dry or humid conditions or extremely hot or cold conditions. Storing them in extreme conditions can cause print-quality problems or cause them to jam in the printer.
- Rotate stock frequently. Long periods of storage in extreme conditions can cause labels to curl and jam in the printer.
- In the print driver software, select **Label** as the paper type.
- Before loading labels, remove all other paper from the bypass tray.

Loading Labels in the Bypass Tray

To load labels in the bypass tray:

1. Open the bypass tray.

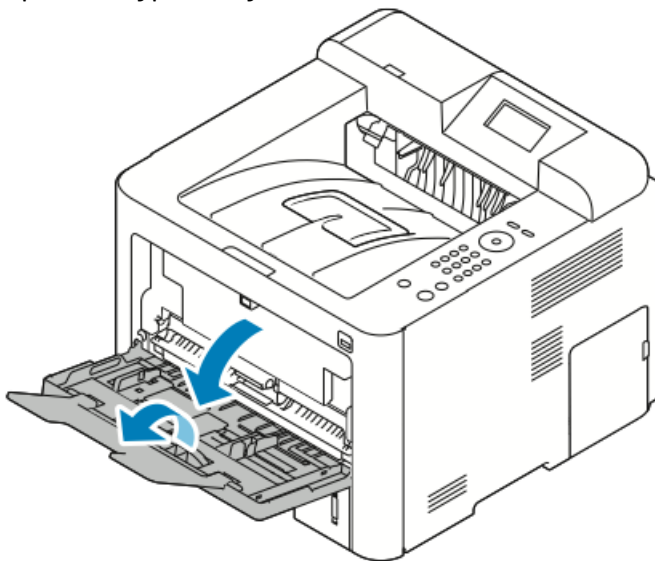

2. Move the width guides to the edges of the tray.

3. Load the labels face up.

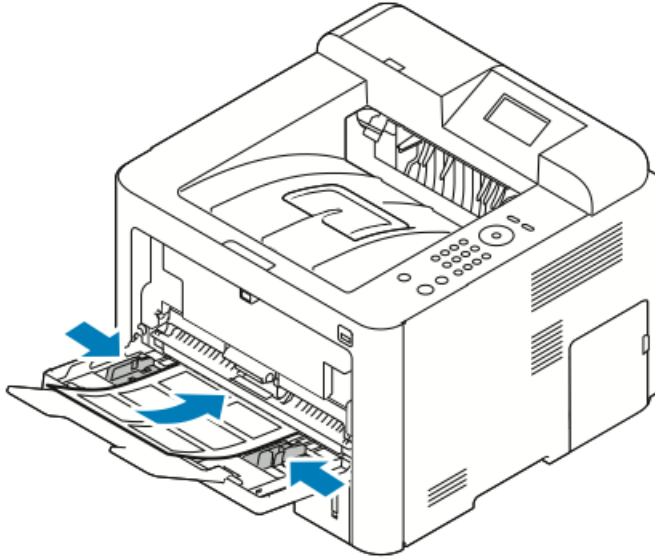

4. Adjust the guides until they touch the edges of the paper.
5. If the control panel prompts you, verify the paper size, type, and color in the Paper Settings screen.
6. When finished, touch **Confirm**.

Transparencies

Note

You can print transparencies from either the Bypass tray or from Tray 1.

Guidelines for Printing Transparencies

Remove all paper before loading transparencies in the tray.

- Handle transparencies by the edges using both hands. Fingerprints or creases can cause poor print quality.
- After loading transparencies, change the paper type to Transparency on the printer control panel.
- In the print driver software, for paper type, select Transparency.
- Do not load more than 20 transparencies. Overloading the tray can cause the printer to jam.
- Do not fan transparencies.

5

Printing

Printing Overview

Before printing, your computer and the printer must be plugged in, turned on, and connected to an active network. Make sure that you have the correct print driver software installed on your computer. For details, see [Installing the Software](#).

1. Select the appropriate paper.
2. Load paper in the appropriate tray.
3. At the printer control panel, specify the size and type.
4. In your software application, access the print settings. For most software applications, press **CTRL > P** for Windows or **CMD > P** for Macintosh.
5. Select your printer.
6. To access the print driver settings for Windows, select **Properties** or **Preferences**. For Macintosh select **Xerox® Features**.
7. Select the desired options.
8. To send the job to the printer, click **Print**.

Related Topics:

[Loading Paper](#)

[Selecting Printing Options](#)

[Printing on Both Sides of the Paper](#)

[Printing on Special Paper](#)

Selecting Printing Options

Printing options, also called print driver software options, are specified as **Printing Preferences** in Windows, and **Xerox® Features** in Macintosh. Printing options include settings for 2-sided printing, page layout, and print quality. You can choose default settings for various printing options; for more information refer to [Setting Default Printing Options for Windows](#) and [Selecting Printing Options for Macintosh](#). Printing options that you set from within the software application are temporary and are not saved.

Print Driver Help

Xerox® print driver software Help is available from the Printing Preferences window. To see print driver help, click the **Help (?)** button in the bottom left corner of the Printing Preferences window.

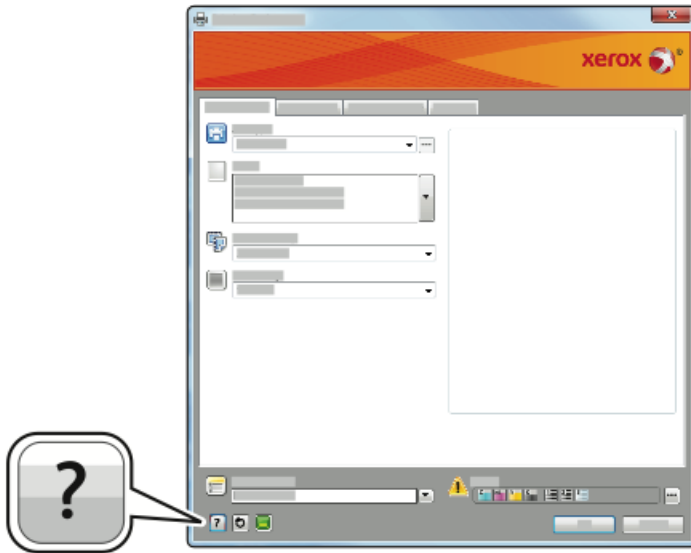

Information about Printing Preferences appears in the Help window on two tabs:

- **Contents** provides a list of the driver tabs at the top and the areas at the bottom of the Printing Preferences window. To find explanations for each of the driver fields and areas, in the Printing Preferences window, click the Contents tab.
- **Search** provides a field where you can enter the topic or function for which you need information.

Windows Printing Options

Setting Default Printing Options for Windows

When you print from any software application, the printer uses the print job settings specified in the Printing Preferences window. You can specify your most common printing options and save them so that you do not have to change them every time you print.

For example, if you want to print on both sides of the paper for most jobs, in Printing Preferences, specify 2-sided printing.

To select default printing options:

1. On your computer, navigate to the list of printers:
 - a) For Windows Vista, click **Start > Control Panel > Hardware and Sound > Printers**.
 - b) For Windows 7, click **Start > Devices and Printers**.
 - c) For Windows 8, click **Control Panel > Devices and Printers**.

Note

If the Control Panel icon does not appear on the desktop, right-click on the desktop, then select **Personalize > Control Panel Home > Devices and Printers**.

2. In the list, right-click the icon for your printer and click **Printing Preferences**.
3. In the Printing Preferences window, click a tab, select the options, then click **OK** to save.

For more information about Windows print driver options, in the Printing Preferences window, click the **Help** button (?).

Selecting Windows Print Options for an Individual Job

To use special printing options for a particular job, you can change the Printing Preferences before sending the job to the printer. For example, if you want the highest print quality when you print a document, in Printing Preferences, select **Enhanced**, then submit the print job.

1. With the document open in your software application, access the print settings. For most software applications, click **File > Print** or press **CTRL > P**.
2. To open the Properties window, select your printer, then click the **Properties** or **Preferences** button. The title of the button varies depending on your application.
3. In the Properties window, click a tab, then make selections.
4. To save your selections and close the Properties window, click **OK**.
5. To send the job to the printer, click **OK**.

Saving a Set of Commonly Used Printing Options for Windows

You can define and save a set of options, so that you can apply them to future print jobs.

To save a set of printing options:

1. With the document open in your application, click **File > Print**.
2. Select the printer, then click **Properties**.
3. In the Properties window, select the desired settings for each tab.
4. To save the settings, click the **arrow** to the right of the Saved Settings field at the bottom of the window, then click **Save As**.
5. Type a name for the set of printing options, then to save the set of options in the Saved Settings list, click **OK**.
6. To print using these options, select the name from the list.

Macintosh Printing Options

Selecting Printing Options for Macintosh

To use specific printing options, change the settings before sending the job to the printer.

1. With the document open in your application, click **File > Print**.
2. Select your printer.
3. Select **Xerox® Features**.
4. Select the desired options.
5. Click **Print**.

Saving a Set of Commonly Used Printing Options for Macintosh

You can define and save a set of options, so that you can apply them to future print jobs.

To save a set of printing options:

1. With the document open in your application, click **File > Print**.
2. In the printer list, select your printer.
3. Select the desired printing options.
4. To save the settings, select **Save Current Settings as Preset**.

Linux Printing Options

Launching Xerox® Printer Manager

To launch Xerox® Printer Manager from a command line prompt:

1. Login in as root.
2. Type xeroxprtmgr.
3. Press **Enter** or **Return**.

Printing from a Linux Workstation

The Xerox® print driver accepts a job ticket setting file that contains preset printing features. You can also submit print requests through the command line using lp/lpr. For more information about Linux printing, click the **Help (?)** button in the Xerox® print driver.

1. Create a print queue. To set up a queue, refer to the *System Administrator Guide* at www.xerox.com/office/3330docs.
2. With the desired document or graphic open in your application, open the Print dialog box.

For most software applications, click **File > Print** or press **CTRL > P**.

3. Select the target print queue.
4. Close the Print dialog box.
5. In the Xerox® print driver, select the available printer features.
6. Click **Print**.

Creating a Job Ticket Using the Xerox Print Driver

1. In a command line prompt, open the Xerox® print driver, login as root, and type **xeroxprtmgr**.
2. On the My Printers screen, select the printer.
3. In the top corner, click **Edit Printer**, then select options for the print job.
4. Click **Save As**, then store the job ticket in your home directory.

Personally identifiable information, such as a Secure Print passcode, is not saved in the job ticket. You can specify the information on the command line.

To print using the job ticket, type the command **lp -d{Target_Queue} -oJT=<path_to_ticket> <file_name>**.

The following commands are examples of how to print using a job ticket:

```
lp -d{Target_Queue} -oJT={Absolute_Path_To_Job_Ticket}
{Path_To_Print_File}
```

```
lp -dMyQueue -oJT=/tmp/DuplexedLetterhead /home/user/PrintReadyFile
```

```
lp -dMyQueue -oJT=/tmp/Secure -oSecurePasscode=1234
/home/user/PrintReadyFile
```

Printing Features

Printing on Both Sides of the Paper

Paper Types for Automatic 2-Sided Printing





The printer can print a 2-sided document automatically on supported paper. Before printing a 2-sided document, verify that the paper type and weight are supported. For details, see [Supported Paper Types and Weights for Automatic 2-Sided Printing](#).

Printing a 2-Sided Document

Options for Automatic 2-Sided Printing are specified in the print driver. The print driver uses the settings for portrait or landscape orientation from the application for printing the document.

2-Sided Page Layout Options

You can specify the page layout for 2-sided printing, which determines how the printed pages turn. These settings override the application page-orientation settings.

Portrait		Landscape	
			

Portrait		Landscape	
2-Sided Print	2-Sided Print, Flip on Short Edge	2-Sided Print	2-Sided Print, Flip on Short Edge

Selecting Paper Options for Printing

There are two ways to select the paper for your print job:

- Let the printer automatically select which paper to use based on the document size, paper type, and paper color you specify.
- Select a specific tray loaded with the desired paper.

Printing Multiple Pages to a Single Sheet

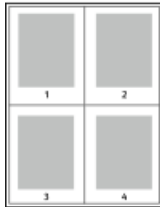

When printing a multiple-page document, you can print more than one page on a single sheet of paper.

1. On the Page Layout tab, select **Pages Per Sheet**.
2. Select **1, 2, 4, 6, 9, or 16** pages per side.

Page Layout is on the Document Options tab.

Scaling

Scaling reduces or enlarges the original document to match the selected output paper size. In Windows, the Scale Options are located in the print driver on the Printing Options tab in the Paper field.

To access Scale Options, click the arrow at the right side of the Paper field, select **Other Size**, then select **Advanced Paper Size**.

- **No Scaling:** This option does not change the size of the page image printed on the output paper, and 100% appears in the percentage box. If the original size is larger than the output size, the page image is cropped. If the original size is smaller than the output size, extra space appears around the page image.
- **Automatically Scale:** This option scales the document to fit the selected Output Paper Size. The scaling amount appears in the percentage box below the sample image.
- **Manually Scale:** This option scales the document by the amount entered in the percentage box below the preview image.

Print Quality

Print-quality modes:

- Standard print-quality mode: 600 x 600 dpi (dots per inch)
- Enhanced print-quality mode: 600 x 600 x 5 dpi (1200 x 1200 enhanced image quality)

Note

The print resolutions are indicated for PostScript print drivers only. The only print-quality mode for PCL is Enhanced.

Printing from a USB Flash Drive

You can print **.pdf**, **.ps**, **.pcl**, **.prn**, **.tiff**, and **.xps** files directly from a USB Flash drive.

Note

If USB ports are disabled, you cannot use a USB card reader for authentication, to update the software, or to print from a USB Flash drive.

The system administrator must set up this feature before you can use it. For details, refer to the *System Administrator Guide* at www.xerox.com/office/3330docs.

To print from a USB Flash drive:

1. Insert your USB Flash drive in a USB port on the printer.
The Print from USB choice is highlighted on the control panel display.
2. Press the **Right** arrow button.
3. To scroll through the list and locate the printable file, use the **Up/Down** arrow buttons.
4. With the file you want to print highlighted, press the **OK** button.
5. Select the number of copies, and press the **OKOK** button.
6. Highlight the tray selection and press the **OK** button.

6

Maintenance

Cleaning the Printer

General Precautions

 **Caution**

When cleaning your printer do not use organic or strong chemical solvents or aerosol cleaners. Do not pour fluids directly into any area. Use supplies and cleaning materials only as directed in this documentation.

 **Warning**

Keep all cleaning materials out of the reach of children.

 **Warning**

Do not use pressurized spray cleaning aids on or in the printer. Some pressurized sprays contain explosive mixtures and are not suitable for use in electrical applications. Use of pressurized spray cleaners increases the risk of fire and explosion.

 **Caution**

Do not remove the covers or guards that are fastened with screws. You cannot maintain or service any parts that are behind these covers and guards. Do not attempt any maintenance procedure that is not described in the documentation supplied with your printer.

 **Warning**

Internal parts of the printer can be hot. Use caution when doors and covers are open.

- Do not place anything on top of the printer.
- Do not open covers and doors during printing.
- Do not tilt the printer while it is in use.
- Do not touch the electrical contacts or gears. Doing so could damage the printer and cause the print quality to deteriorate.
- Ensure that any parts removed during cleaning are replaced before you plug in the printer.

Cleaning the Exterior

Clean the exterior of the printer once a month.

Caution

Do not spray detergent directly on the printer. Liquid detergent could enter the printer through a gap and cause problems. Never use cleaning agents other than water or mild detergent.

1. Wipe the paper tray, output tray, control panel, and other parts with a damp, soft cloth.
2. After cleaning, wipe with a dry, soft cloth.

Note

For stubborn stains, apply a small amount of mild detergent to the cloth and gently wipe the stain off.

Ordering Supplies

When to Order Supplies

A warning appears on the control panel display when the Toner Cartridge or the Drum Cartridge are near their replacement time. Verify that you have replacements on hand. It is important to order these items when the messages first appear to avoid interruptions to your printing. An error message appears on the control panel display when the Toner Cartridge or the Drum Cartridge must be replaced.

Order supplies from your local reseller or go to www.xerox.com/office/3330supplies.

Caution

Use of non-Xerox supplies is not recommended. The Xerox Warranty, Service Agreement, and Total Satisfaction Guarantee do not cover damage, malfunction, or degradation of performance caused by use of non-Xerox supplies, or the use of Xerox supplies not specified for this printer. The Total Satisfaction Guarantee is available in the United States and Canada. Coverage could vary outside these areas. Please contact your Xerox representative for details.

Viewing Printer Supply Status

You can check the status and percentage of life remaining for your printer supplies at any time using the control panel.

1. At the printer, press the **Menu** button.
2. Using the **Down** arrow button, select **Information**.
3. Press the **Right** arrow button.
4. Using the **Down** arrow button, select **Supplies Info**. Press the **Right** arrow button.

A list of Supplies information appears. Using the **Up/Down** arrow buttons, select your choice to view status.

Consumables

Consumables are printer supplies that get depleted during the operation of the printer. The consumable supplies for this printer is the genuine Xerox® Black Toner Cartridge and the Xerox® Smart Kit Drum Cartridge.

Note

- Each consumable includes installation instructions.
- To ensure print quality, the toner cartridge and drum cartridge are designed to cease functioning at a predetermined point.

Caution

Use of non-Xerox supplies is not recommended. Use of toner with other than genuine Xerox® Toner can affect print quality and printer reliability. Xerox® Toner is the only toner designed and manufactured under strict quality controls by Xerox for use with this specific printer.

Routine Maintenance Items

Routine maintenance items are printer parts that have a limited life and require periodic replacement. Replacements can be parts or kits. Routine maintenance items are typically customer replaceable.

Note

Each routine maintenance item includes installation instructions.

Routine maintenance items for this printer include the following:

- Standard Capacity Toner Cartridge
- High Capacity Toner Cartridge
- Extra High-Capacity Toner Cartridge
- Drum Cartridge

Note

Not all options listed are supported on all printers. Some options apply only to specific printer models or configurations.

Toner Cartridges

General Precautions for the Toner Cartridge

 **Warning**

- When replacing a toner cartridge, be careful not to spill the toner. If any toner spills, avoid contact with clothes, skin, eyes, and mouth. Do not inhale the toner dust.
- Keep toner cartridges out of the reach of children. If a child accidentally swallows toner, have the child spit out the toner, and rinse the mouth with water. Consult a physician immediately.
- Use a damp cloth to wipe off spilled toner. Never use a vacuum cleaner to remove spills. Electric sparks inside the vacuum cleaner can cause a fire or explosion. If you spill a large volume of toner, contact your local Xerox representative.
- Never throw a toner cartridge into an open flame. Remaining toner in the cartridge can catch fire and cause burn injuries or an explosion.

Replacing a Toner Cartridge

When a toner cartridge approaches the end of its usable life span, the control panel displays a toner low message. When a toner cartridge is empty, the printer stops and displays a message on the control panel.

Note

Each toner cartridge includes installation instructions.

Printer Status Message	Cause and Solution
Low Toner Status. Ensure that a new Toner Cartridge is available.	The toner cartridge is low. Order a new toner cartridge.
Replace Toner Cartridge	The toner cartridge is empty. Open the side door and then the front cover, then replace the toner cartridge.

Drum Cartridges

General Precautions for the Drum Cartridge

 **Caution**

Do not expose the drum cartridge to direct sunlight or strong indoor fluorescent lighting. Do not touch or scratch the surface of the drum.

 **Caution**

Do not leave the covers and doors open for any length of time, especially in well-lit places. Light exposure can damage the drum cartridge.

 **Warning**

Never throw a drum cartridge into an open flame. The cartridge can catch fire and cause burn injuries or an explosion.

Replacing a Drum Cartridge

When a drum cartridge approaches the end of its usable life span, the control panel displays a drum cartridge low message. When a drum cartridge is empty, the printer stops and displays a message on the control panel.

Note

Each drum cartridge includes installation instructions.

Printer Status Message	Cause and Solution
Image Unit Low Status. Ensure that a new Drum Cartridge is available.	The drum cartridge is low. Order a new drum cartridge.
No message but the printer stops printing.	The drum cartridge must be replaced. Open the front cover, then replace the drum cartridge.

Recycling Supplies

For more information on the Xerox® supplies recycling program, go to:
www.xerox.com/gwa.

Moving the Printer

Warning

To prevent electric shock, never touch the power plug with wet hands. When removing the power cord, ensure that you pull the plug and not the cord. Pulling the cord can damage it, which can lead to fire or electric shock.

Warning

When moving the printer, do not tilt it more than 10 degrees to the front, back, left, or right. Tilting the printer more than 10 degrees can cause toner spillage.

Warning

If the optional 550-sheet feeder is installed, uninstall it before you move the printer. If the optional 550-sheet feeder is not fixed to the printer securely, it can fall to the ground and cause injury.

Follow these instructions when moving the printer:

1. Turn off the printer and wait for the printer to shut down. For details, see [Turning On/Off the Printer](#).
2. Remove any paper or other media from the output tray.
3. When moving the printer from one location to another, use caution to ensure that the printer does not topple.

4. Lift and carry the printer as shown in the illustration.



- To prevent dropping or tipping the printer, hold the printer with one hand underneath to hold the printer and the other hand on top to stabilize it.
- Repack the printer and its options using the original packing material and boxes or a Xerox Repackaging Kit. For a repackaging kit and instructions, go to www.xerox.com/office/3330support.
- When moving the printer over a long distance, remove the toner cartridges and drum cartridges to prevent toner from spilling.

! Caution

Failure to repackage the printer properly for shipment can result in damage not covered by the Xerox® Warranty, Service Agreement, or Total Satisfaction Guarantee. The Xerox® Warranty, Service Agreement, or Total Satisfaction Guarantee do not cover damage to the printer caused by improper moving.

5. After moving the printer:
 - a) Reinstall any parts you removed.
 - b) Reconnect the printer to the cables and power cord.
 - c) Plug in and turn on the printer.

Billing and Usage Counters Information

Billing and printer usage information appears on the Billing Meters information screen at the control panel display. The impression counts shown are used for billing.

To view Billing and Usage information:

1. At the printer control panel, press the **Menu** button.
2. Press the **Down** arrow button to select **Information**.
3. Press the **Right** arrow button, then use the **Down** arrow button to select **Billing Meters**.
4. Press the **Right** arrow button to view a list of information types.

7

Troubleshooting

General Troubleshooting

This section contains procedures to help you locate and resolve problems. Resolve some problems by simply restarting the printer.

Restarting the Printer

To restart the printer:

1. Press the **Power** button.
2. Press the **Down** arrow button, and select **Power Down** on the control panel display.
3. Press the **OK** button.
The printer powers down.
4. After one minute, press the **Power** button.
The printer begins initializing, and then reports that it is ready to print. A Configuration Report prints.

Printer Fails to Power On

Probable Causes	Solutions
The power switch is not turned on.	Turn on the power switch.
The power cord is not correctly plugged into the outlet.	Turn off the printer power switch, and plug the power cord securely into the outlet.
Something is wrong with the outlet connected to the printer.	Plug another electrical appliance into the outlet and see if it operates properly. Try a different outlet.
The printer is connected to an outlet with a voltage or frequency that does not match the printer specifications.	Use a power source within the specifications for the printer.

 **Caution**

Plug the three-wire cord with grounding prong directly into a grounded AC outlet.

Related Topics:

[Electrical Specifications](#)

Printer Resets or Turns Off Frequently

Probable Causes	Solutions
The power cord is not plugged into the outlet correctly.	Turn off the printer, confirm that the power cord is plugged in correctly to the printer and the outlet, then turn on the printer.
A system error occurred.	Turn off the printer, then turn it on again. Print the Error Messages report from the Troubleshooting Pages menu. If the error persists, contact your Xerox representative.
The printer is connected to an uninterruptible power supply.	Turn off the printer, then connect the power cord to a suitable outlet.
The printer is connected to a power strip shared with other high-power devices.	Plug the printer directly into the outlet or into a power strip that is not shared with other high-power devices.

Document Prints from Wrong Tray

Probable Causes	Solutions
Application and print driver have conflicting tray selections.	<ol style="list-style-type: none"> 1. Check the tray selected in the print driver. 2. Go to the page setup or printer settings of the application from which you are printing. 3. Set the paper source to match the tray selected in the print driver or set the paper source to Automatically Select.

Automatic 2-Sided Printing Problems

Probable Causes	Solutions
Unsupported or incorrect paper	Ensure that you are using a supported paper size and weight for 2-sided printing. Envelopes and labels cannot be used for 2-sided printing. For details, see Supported Types and Weights for Automatic 2-Sided Printing and Supported Standard Paper Sizes for Automatic 2-Sided Printing .

Probable Causes	Solutions
Incorrect setting	In the print driver Properties, select 2-Sided Print on the Paper/Output tab.

Paper Tray Fails to Close

Probable Cause	Solution
The paper tray does not close fully.	Some debris or an object is blocking the tray.

Printing Takes Too Long

Probable Causes	Solutions
The printer is set to a slower printing mode. For example, the printer could be set to print on Heavyweight paper.	It takes more time to print on certain types of special paper. Ensure that the paper type is set properly in the driver and at the printer control panel.
The printer is in Power Saver mode.	It takes time for printing to start when the printer is exiting of Power Saver mode.
The way the printer was installed on the network could be an issue.	Determine if a print spooler or a computer sharing the printer is buffering all print jobs and then spooling them to the printer. Spooling can slow print speeds. To test the speed of the printer, print some information pages such as the Office Demo Page. If the page prints at the rated speed of the printer, you could have a network or printer installation issue. For additional help, contact the system administrator.
The job is complex.	Wait. No action needed.
The print-quality mode in the driver is set to Enhanced .	Change the print-quality mode in the print driver to Standard .

Printer Fails to Print

Probable Causes	Solutions
The printer has an error.	To clear the error, follow the onscreen prompts. If the error persists, contact your Xerox representative.
The printer is out of paper.	Load paper into the tray.
A toner cartridge is empty.	Replace the empty toner cartridge.

Troubleshooting

Probable Causes	Solutions
The power cord is not correctly plugged into the outlet.	Turn off the printer, confirm that the power cord is plugged in correctly to the printer and the outlet, then turn on the printer. For details, see Turning On/Off the Printer . If the error persists, contact your Xerox representative.
The printer is busy.	<ul style="list-style-type: none">• A previous print job could be the problem. On your computer, you can use the printer properties to delete all print jobs in the print queue.• Load the paper in the tray.• At the printer control panel, press the Job Status button. If the print job does not appear check the Ethernet connection between the printer and the computer.• At the printer control panel, press the Job Status button. If the print job does not appear, check the USB connection between the printer and the computer. Turn off the printer, then turn it on again.
The printer cable is disconnected.	<ul style="list-style-type: none">• At the printer control panel, press the Job Status button. If the print job does not appear check the Ethernet connection between the printer and the computer.• At the printer control panel, press the Job Status button. If the print job does not appear, check the USB connection between the printer and the computer. Turn off the printer, then turn it on again.

Printer Makes Unusual Noises

Probable Causes	Solutions
There is an obstruction or debris inside the printer.	Turn off the printer and then remove the obstruction or debris. If you cannot remove it, contact your Xerox representative.

Condensation has Formed Inside the Printer

Moisture can condense inside a printer where the humidity is above 85 % or when a cold printer is located in a warm room. Condensation can form in a printer after it has been sitting in a cold room that is heated quickly.

Probable Causes	Solutions
The printer has been sitting in a cold room.	<ul style="list-style-type: none"> • Allow the printer to acclimate for several hours before operation. • Allow the printer to operate for several hours at room temperature.
The relative humidity of the room is too high.	<ul style="list-style-type: none"> • Reduce the humidity in the room. • Move the printer to a location where the temperature and relative humidity are within the operating specifications.

Paper Jams

Minimizing Paper Jams

The printer is designed to function with minimal paper jams using Xerox supported paper. Other paper types can cause jams. If supported paper is jamming frequently in one area, clean that area of the paper path.

The following can cause paper jams:

- Selecting the incorrect paper type in the print driver.
- Using damaged paper.
- Using unsupported paper.
- Loading paper incorrectly.
- Overfilling the tray.
- Adjusting the paper guides improperly.

Most jams can be prevented by following a simple set of rules:

- Use only supported paper. For details, see Supported Paper on page 48.
- Follow proper paper handling and loading techniques.
- Always use clean, undamaged paper.
- Avoid paper that is curled, torn, moist, creased, or folded.
- To separate the sheets before loading into the tray, fan the paper.
- Observe the paper tray fill line; never overfill the tray.

Troubleshooting

- Adjust the paper guides in all trays after inserting the paper. A guide that is not properly adjusted can cause poor print quality, misfeeds, skewed prints, and printer damage.
- After loading the trays, select the correct paper type and size on the control panel.
- When printing, select the correct type and size in the print driver.
- Store paper in a dry location.
- Use only Xerox paper and transparencies designed for the printer.

Avoid the following:

- Polyester coated paper that is specially designed for inkjet printers.
- Paper that is folded, wrinkled, or excessively curled.
- Loading more than one type, size, or weight of paper in a tray at the same time.
- Overfilling the trays.
- Allowing the output tray to overflow.

Locating Paper Jams

Warning

To avoid injury, never touch a labeled area on or near the heat roller in the fuser. If a sheet of paper is wrapped around the heat roller, do not try to remove it immediately. Switch off the printer immediately and wait 30 minutes for the fuser to cool. After the printer cools, try to remove the jammed paper. If the error persists, contact your Xerox representative.

The following illustration shows where paper jams can occur along the paper path:

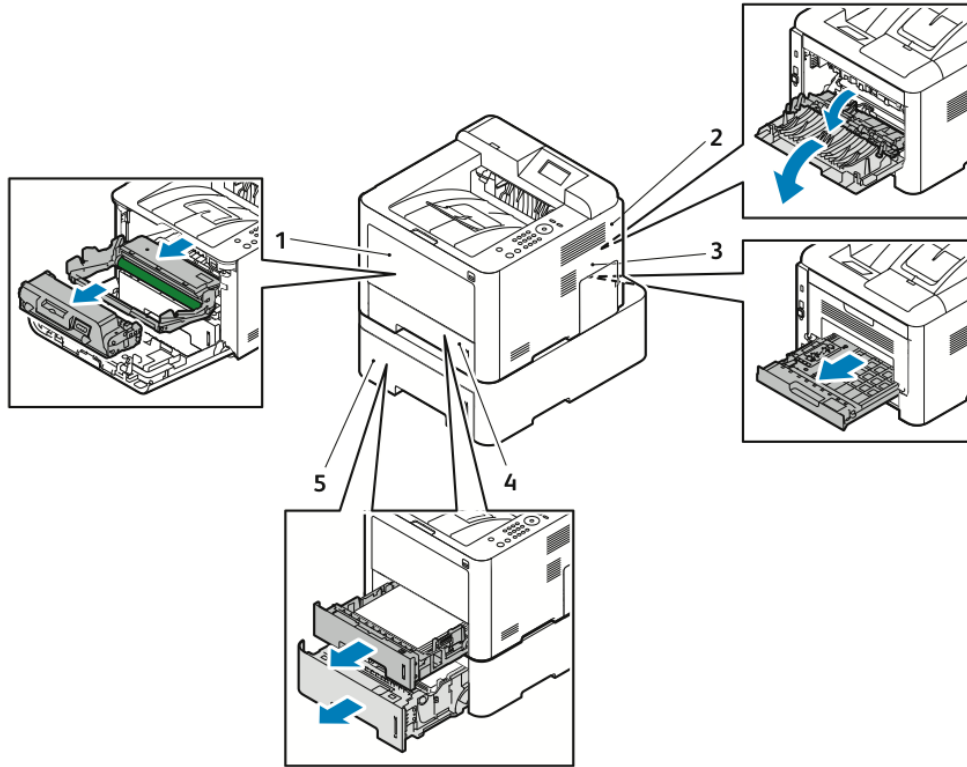

1. Bypass Tray and Inside the Printer
2. Back of the Printer
3. Duplex Unit
4. Tray 1
5. Tray 2

Clearing Paper Jams

Clearing Paper Jams from the Bypass Tray

Note

To resolve the error displayed on the control panel you must clear all paper from the paper path.

1. Remove any paper from the bypass tray. Where the tray connects to the printer, clear any paper that is jammed.

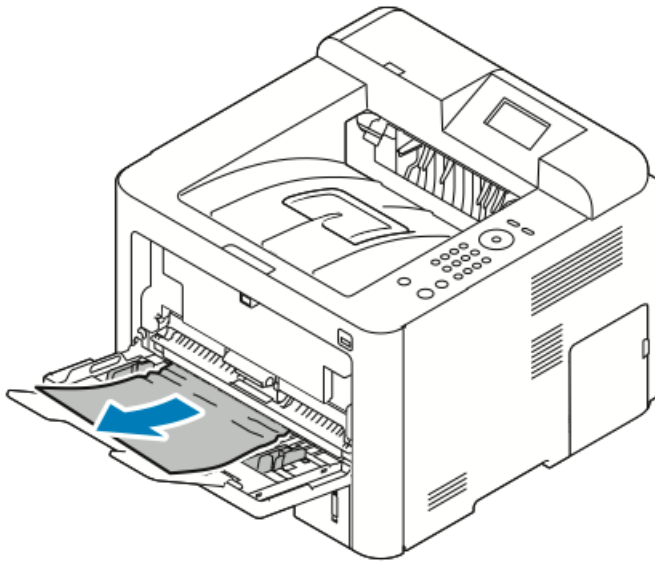

2. If the paper is torn, check inside the printer for pieces of paper, then gently remove them. If you cannot remove the paper fragments easily, contact your Xerox representative.

Warning

The area around the fuser can be hot. Use caution to avoid injury.

3. When you reload the bypass tray, fan the paper and ensure that all four corners align neatly.
4. If the control panel prompts you, verify the size and type and press the **OK** button.

Clearing Paper Jams from Tray 1

Note

To resolve the error displayed on the control panel you must removing any remaining paper from the paper path.

1. Open Tray 1, then pull the tray out and completely away from the printer.

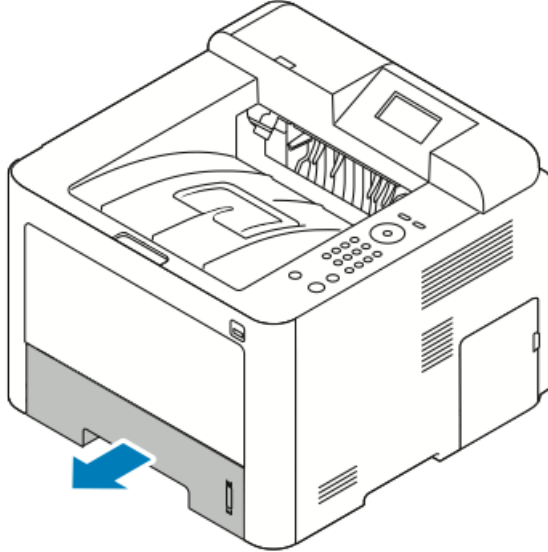

2. Remove crumpled paper from the tray and any remaining paper jammed in the printer.

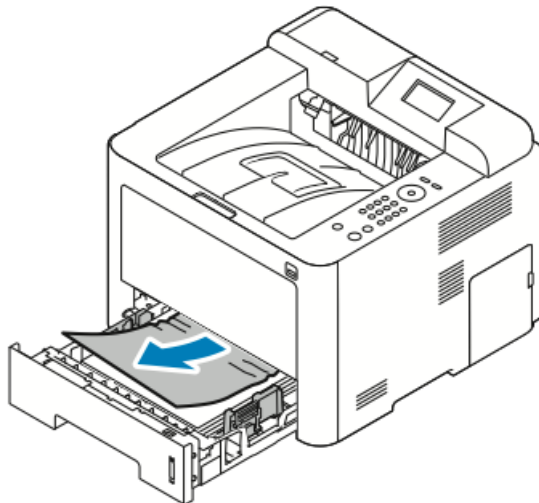

Troubleshooting

3. Carefully reinsert and close the tray.

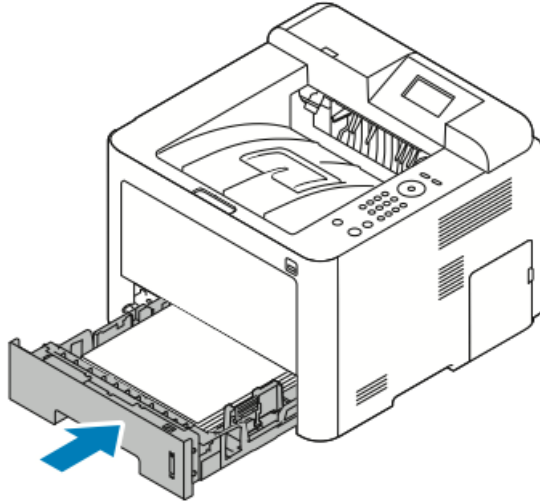

4. If the control panel prompts you, verify the paper size, type, and click the **OK** button..

Clearing Paper Jams from Tray 2

Note

To resolve the error displayed on the control panel you must removing any remaining paper from the paper path.

1. Open Tray 2, and slide it completely out and away from the printer.

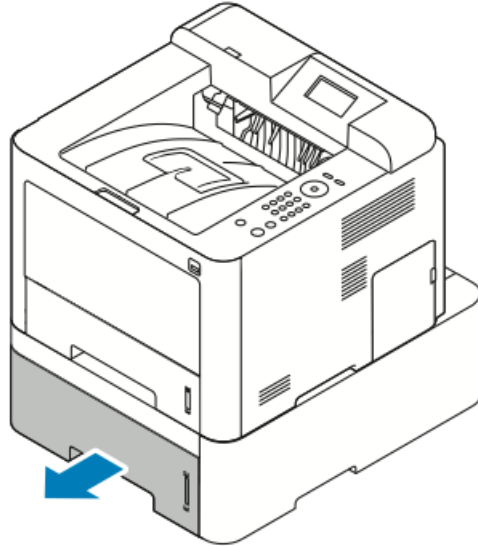

2. Remove any crumpled paper from the tray and any remaining paper jammed in the printer.

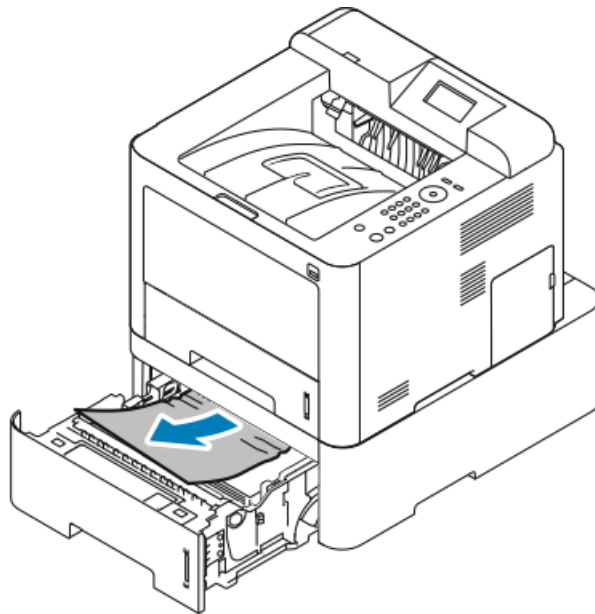

- If the paper does not move when you pull it or if you do not see the paper in this area, stop and go to the [Step 3](#).
- If the paper is removed, go to [Step 4](#).

3. Perform the following steps to locate the jam.

Troubleshooting

a) Open Tray 1.

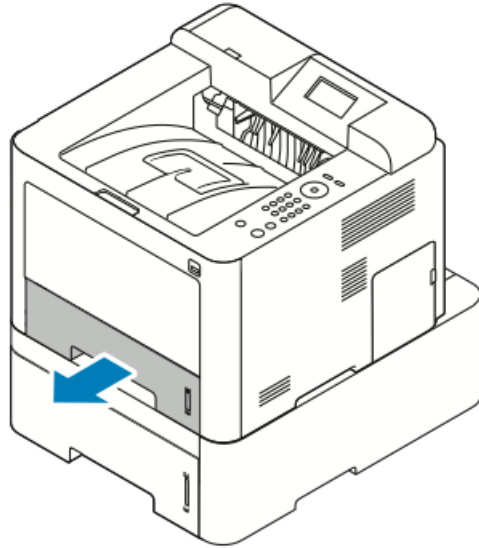

b) Pull the paper straight up and out.

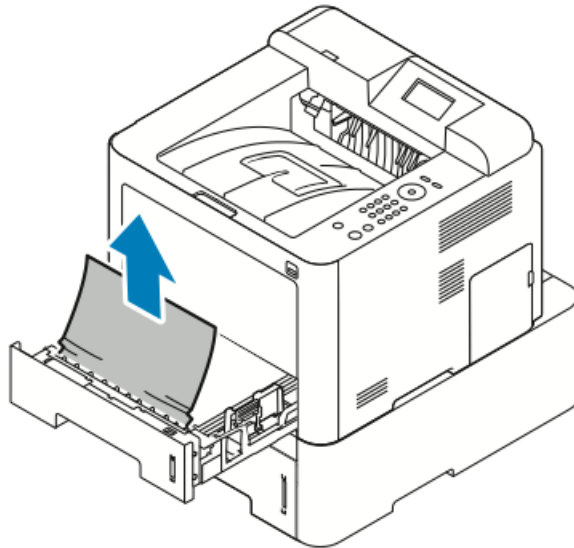

c) Close Tray 1.

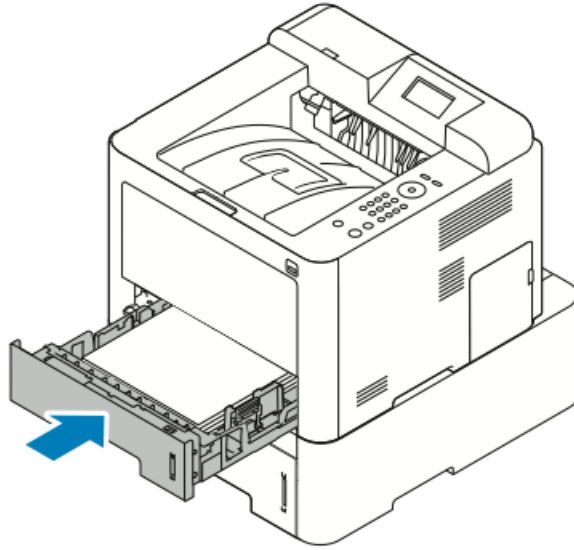

d) Look for any remaining crumpled paper in Tray 2 and remove it.

4. Close the Tray 2.

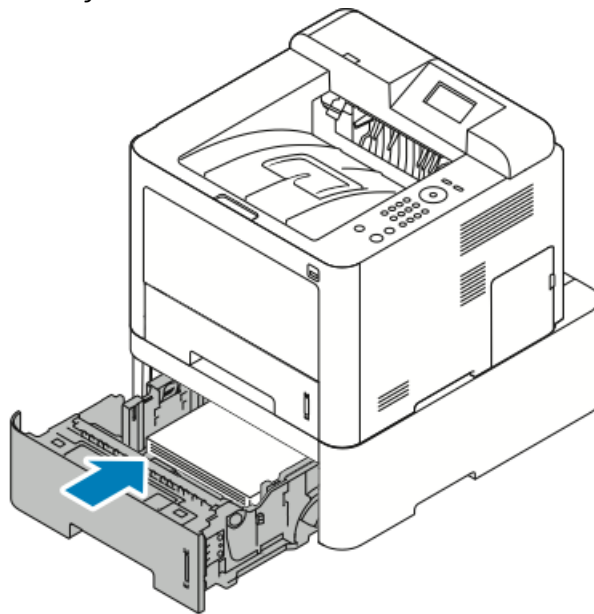

5. If the control panel display prompts you, verify the paper size, type, and press the **OK** button.

Clearing Paper Jams from Inside the Front Cover

To resolve the error displayed on the control panel you must clear all paper from the paper path.

1. To access jammed paper inside the printer, open the front cover.

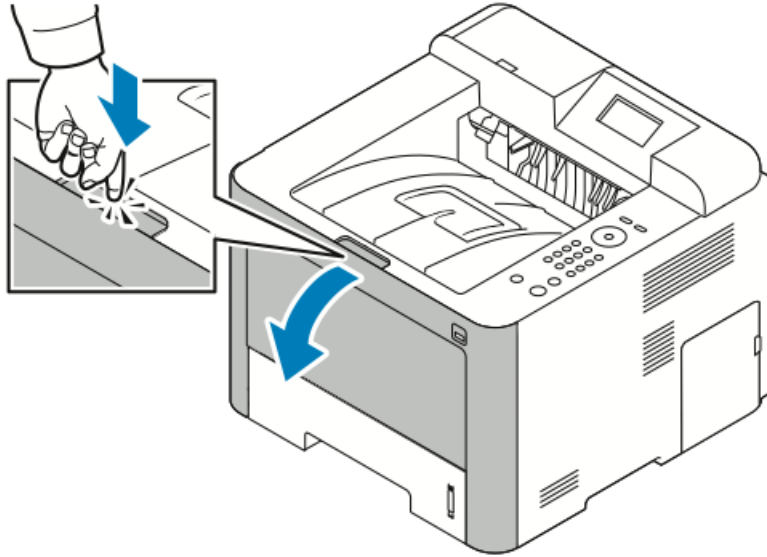

2. Remove any crumpled paper.

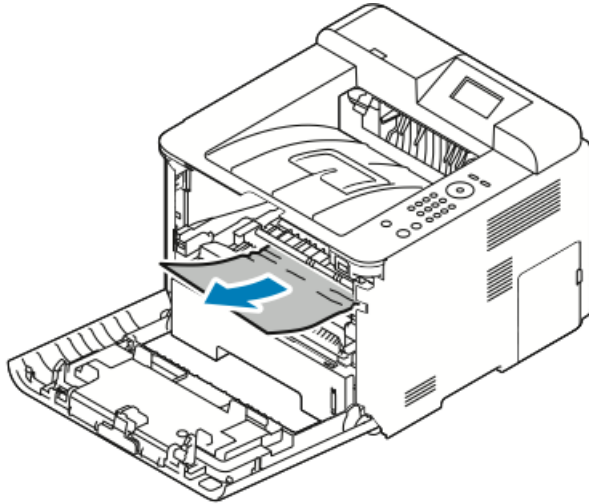

- If the paper does not move when you pull it or if you do not see the paper in this area, stop and go to [Step 3](#).
- If the paper is removed, go to [Step 6](#).

3. Pull out the toner cartridge.

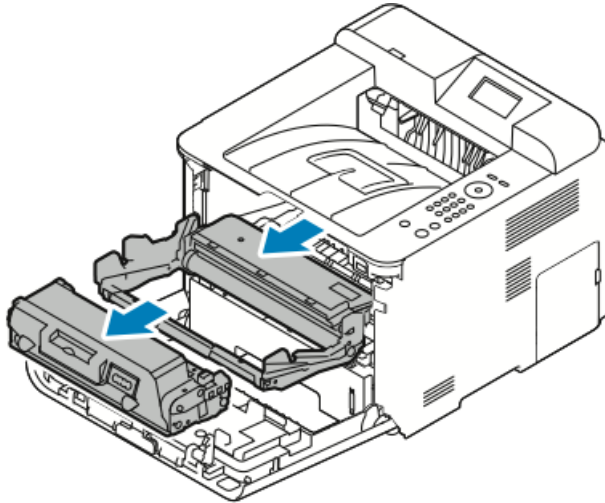

4. Gently remove any paper from inside the printer.
5. Reinstall the toner cartridge and push it into the printer.

Tabs on the sides of the cartridge and corresponding grooves within the printer will guide the cartridge into the correct position until it locks into place.

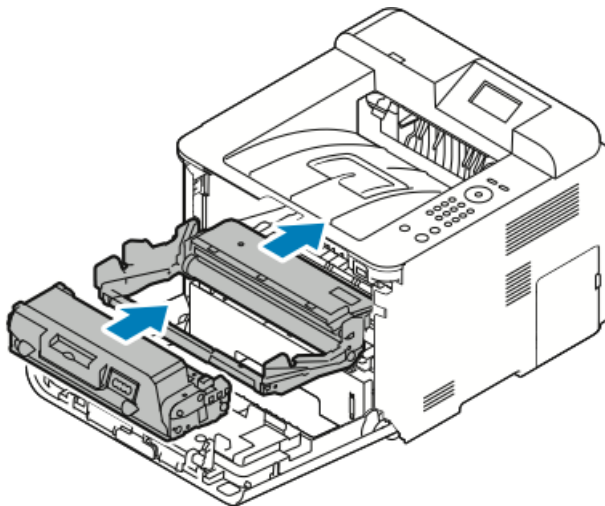

Troubleshooting

6. Close the front cover.

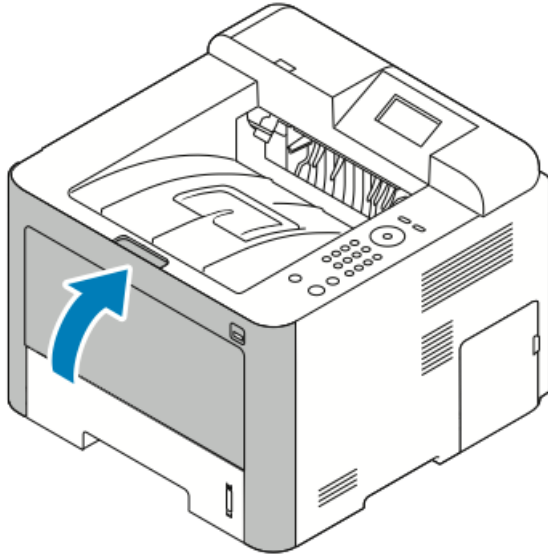

7. If prompted, follow the instructions on the control panel display to continue printing.

Clearing Paper Jams from the Back of the Printer

Note

To resolve the error displayed on the control panel you must clear all paper from the paper path.

1. Pull down the rear cover.

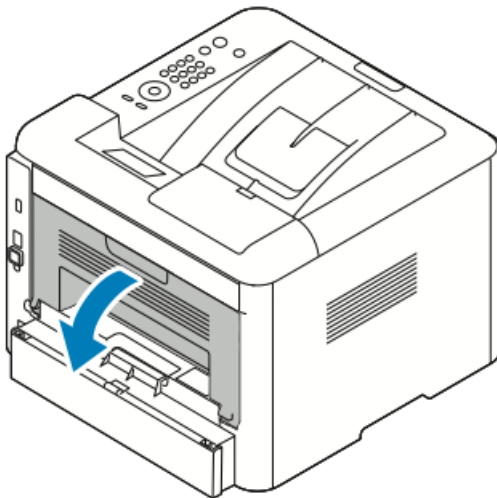

2. Push down the levers as shown.

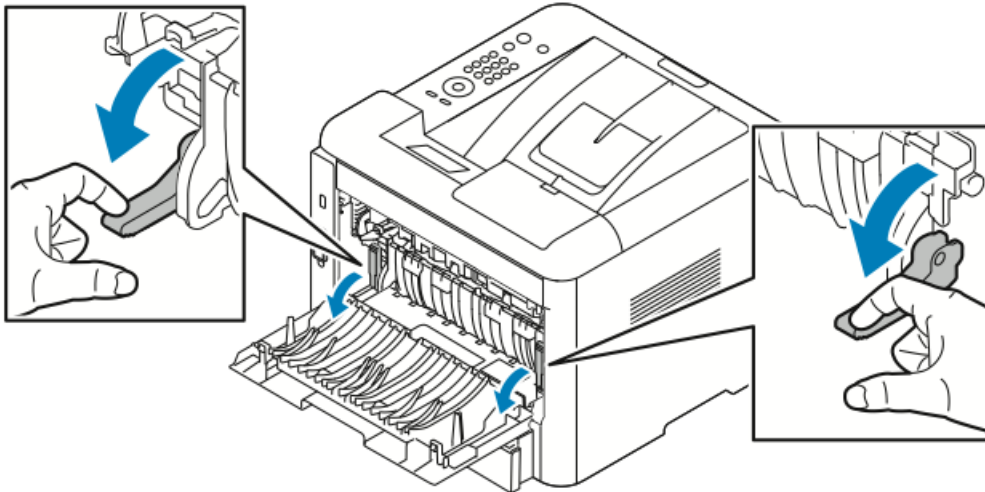

3. To access the fuser area, push down on both sets of levers as shown, and pull down the rollers.

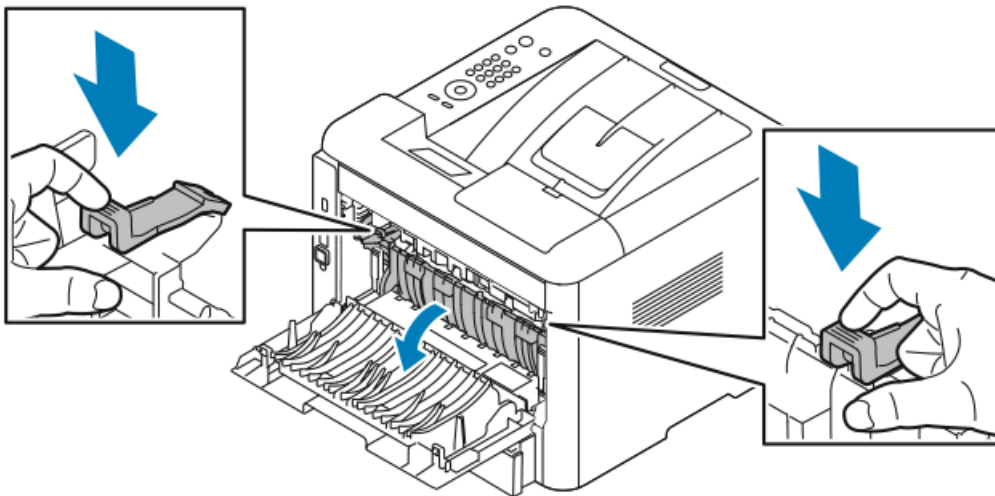

4. Gently remove any jammed paper.

Troubleshooting

Warning

The area around the fuser may be hot. Use caution to avoid any injury.

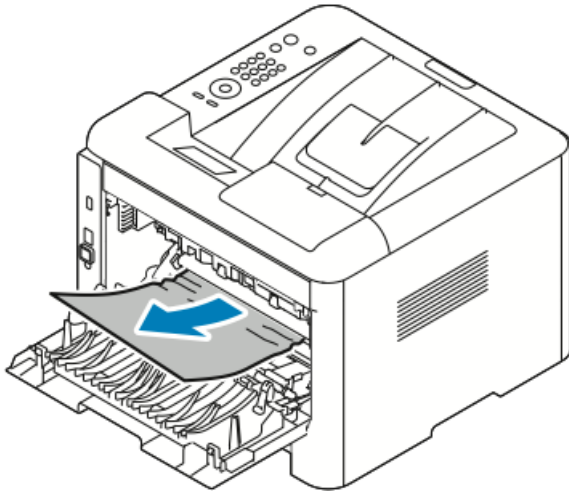

5. Return both sets of levers to their original positions.

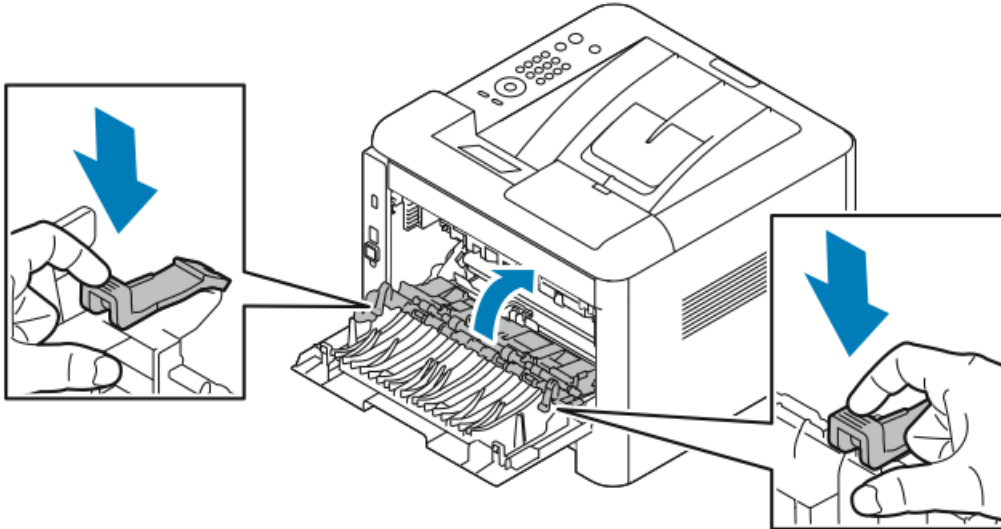

6. Close the rear cover.

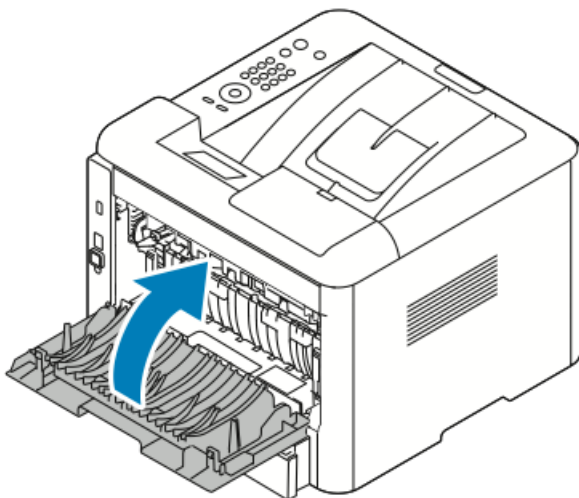

7. If prompted, follow the instructions on the control panel display to continue printing.

Clearing Paper Jams from the Duplex Unit

Note

To resolve the error displayed on the control panel you must clear all paper from the paper path.

1. To access paper jams in the duplex area, perform the following:

- a) Remove the tray 1 rear cover.

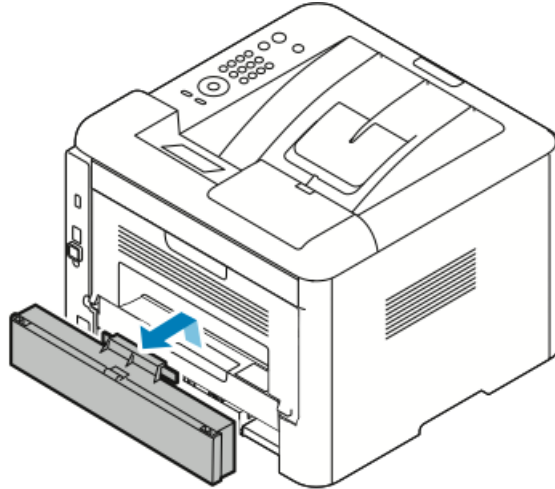

- b) Remove the duplex unit from the printer.

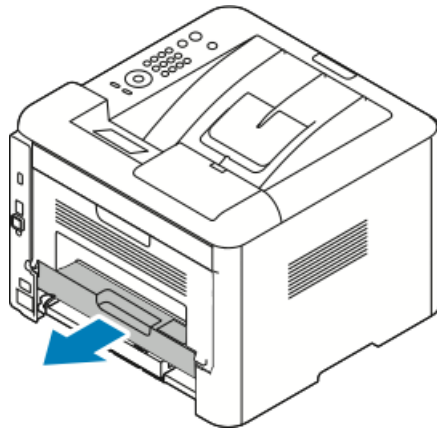

2. Gently remove any paper from the duplex area.

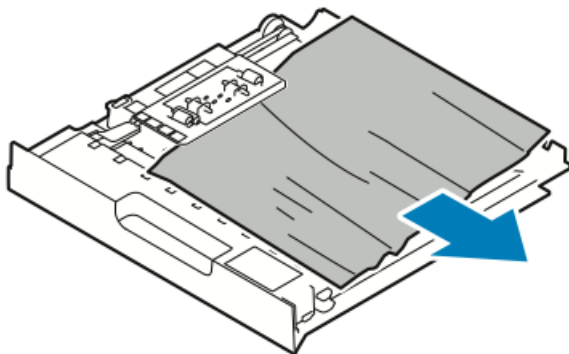

Troubleshooting

If the paper does not come out with the duplex unit, go to the next step.

3. Insert the duplex unit back into the printer, aligning the edges of the unit with the feed grooves on the inside of the printer.
 - a) Ensure that the duplex unit is fully pushed in.

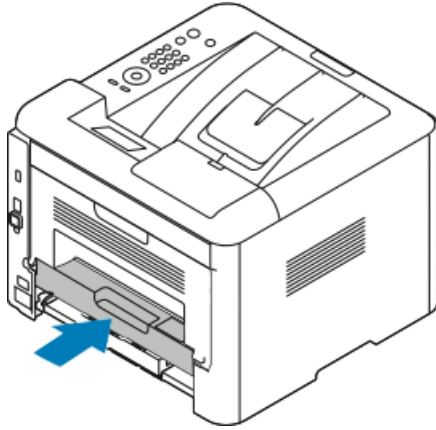

- b) Replace the tray 1 rear cover.

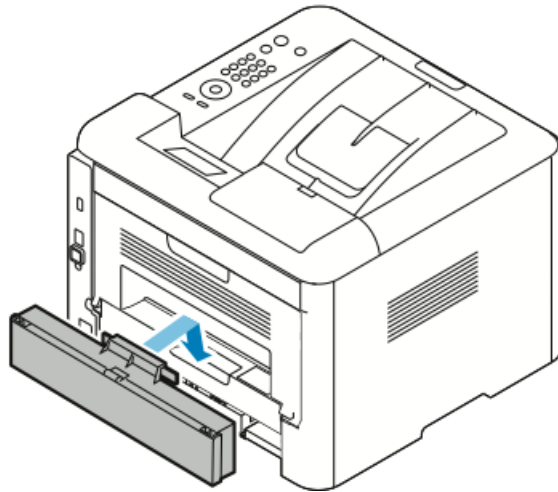

4. If prompted, follow the instructions on the control panel display to continue printing.

Clearing Paper Jams from the Output Area

Note

To resolve the error displayed on the control panel you must clear all paper from the paper path.

1. Gently pull out the paper from the output area.

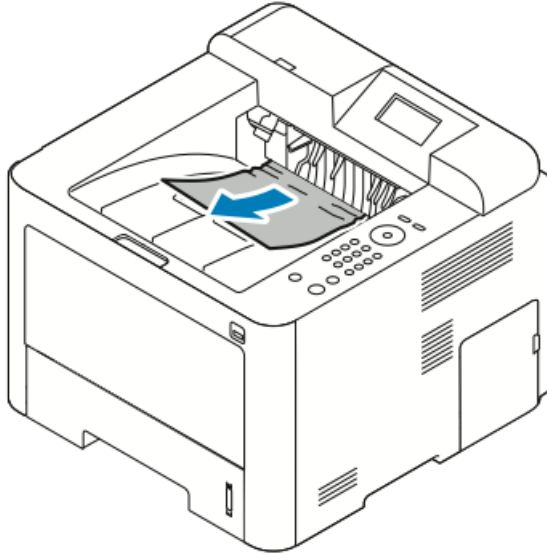

If you do not see the jammed paper or if there is any resistance when you pull, stop and go to [Clearing Paper Jams from the Back of the Printer](#).

2. If prompted, follow the instructions on the control panel display to continue printing.

Troubleshooting Paper Jams

Multiple Sheets Pulled Together

Probable Causes	Solutions
The paper tray is too full.	Remove some of the paper. Do not load paper past the MAX line.
The edges of the paper are not even.	Remove the paper, align the edges, and then reload it.
The paper is moist from humidity.	Remove the paper from the tray, and replace it with new dry paper.
Too much static electricity is present.	Try a new ream of paper. Do not fan transparencies before loading in tray.
Using unsupported paper.	Use only Xerox approved paper. For details, refer to Supported Paper .
Humidity is too high for coated paper.	Feed paper one sheet at a time.

Paper Misfeeds

Probable Causes	Solutions
The paper is not correctly positioned in the tray.	<ul style="list-style-type: none"> Remove the misfed paper and reposition it properly in the tray. Adjust the paper guides in the tray to match the size of the paper.
The paper tray is too full.	Remove some of the paper. Do not load paper past the fill line.
The paper guides are not correctly adjusted to the paper size.	Adjust the paper guides in the tray to match the size of the paper.
The tray contains warped or wrinkled paper.	Do not reuse the paper. Remove the paper, and load the tray with new paper.
The paper is moist from humidity.	Remove the moist paper and replace it with new, dry paper.
Using paper of the wrong size, thickness, or type.	Use only Xerox approved paper. For details, see Supported Paper .

Label and Envelope Misfeeds

Probable Causes	Solutions
Labels are missing, curled, or are pulling away from the backing sheet.	Do not use any sheet where labels are missing, curled, or pulled away from the backing sheet.
The label sheet is facing the wrong way in the tray.	<ul style="list-style-type: none"> Load label sheets according to the instructions from the manufacturer. Load labels print side up in the bypass tray. Do not load labels in the high-capacity feeder.
Envelopes are loaded incorrectly in the bypass tray.	<ul style="list-style-type: none"> Load envelopes in the bypass tray with the print side up, flaps closed, and the short edge leading into the printer. Ensure that the width guides rest loosely against the edge of the envelopes without restricting their movement.
Envelopes are wrinkling.	The heat and pressure of the laser printing process can cause wrinkling. Use supported envelopes. For details refer to Guidelines for Printing Envelopes .

Paper Jam Message Stays On

Probable Causes	Solutions
Some paper remains jammed in the printer.	Recheck the paper path. Ensure that you have removed all of the jammed paper.
One of the printer doors is open.	Check the doors on the printer. Close any door that is open.

Note

Check for any torn pieces of paper in the paper path, then remove the paper.

Jams During Automatic 2-Sided Printing

Probable Causes	Solutions
Using paper of the wrong size, thickness, or type.	<ul style="list-style-type: none"> Use only Xerox approved paper. For details, see Supported Paper Types and Weights for Automatic 2-Sided Printing and Supported Standard Paper Sizes for Automatic 2-Sided Printing. For automatic 2-sided printing, do not use transparencies, envelopes, labels, reused paper, or paper heavier than 105 g/m².
Paper is loaded in the wrong tray.	Load paper in the correct tray. For details, see Supported Paper .
Tray is loaded with mixed paper.	Load the tray with only one type and size of paper.

Print-Quality Problems

Your printer is designed to produce consistently high-quality prints. If you observe print-quality problems, use the information in this section to troubleshoot the problem. For more information, go to www.xerox.com/office/3330support.

Caution

The Xerox Warranty, Service Agreement, or Xerox Total Satisfaction Guarantee does not cover damage caused by using unsupported paper or specialty media. The Xerox Total Satisfaction Guarantee is available in the United States and Canada. Coverage could vary outside these areas. Please contact your local representative for details.

Note

To ensure consistent print quality, the toner cartridges and imaging units for many models of equipment are designed to cease functioning at a predetermined point.

Controlling Print Quality

Various factors can affect the quality of the output of your printer. For consistent and optimum print quality, use paper designed for your printer and set the paper type correctly. Follow the guidelines in this section to maintain optimum print quality from your printer.

Temperature and humidity affect the quality of the printed output. The guaranteed range for optimal print quality is 10–30°C (50–90°F) and 20–80 % relative humidity.

Solving Print-Quality Problems

When the print quality is poor, select the closest symptom from the following table and see the corresponding solution to correct the problem. You can also print a Demo Page to more precisely determine the print-quality problem.





If the print quality does not improve after carrying out the appropriate action, contact your Xerox representative.

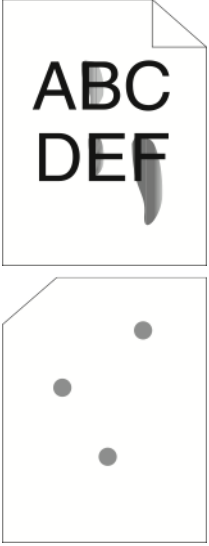
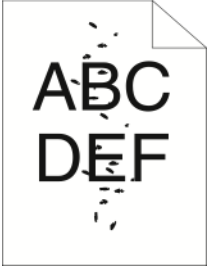
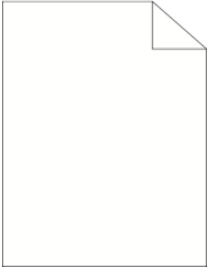

Note

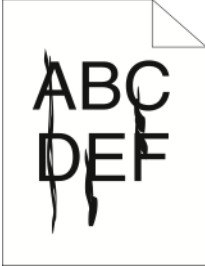
To maintain print quality, the toner cartridge is designed to provide a warning message when the toner level is low. When the toner cartridge reaches this level, a warning message appears. Once the toner cartridge is empty, another message prompts you to replace the toner cartridge. The printer stops printing until you install a new toner cartridge.

Symptom	Solutions
<p>The output is too light.</p> 	<ul style="list-style-type: none"> • To check the toner level, check the control panel, use the print driver, or XeroxSM CentreWareSM Internet Services. If the toner cartridge is near empty, replace it. • Verify that the toner cartridge is approved for use in this printer, and replace it as needed. For best results, use a genuine Xerox toner cartridge. • Ensure that the print quality mode is not set to Toner Saver. Toner Saver is useful for draft quality output. • Replace the paper with a recommended size and type, and confirm that your printer and print driver settings are correct. • Verify that the paper is dry and that supported paper is used. If not, change the paper. • Change the Paper Type settings in the print driver. • In the Printing Preferences of the print driver, on the Paper/Output tab, change the Paper Type setting. • If printer is located in a high altitude environment, adjust the altitude setting of the printer. For details, see the <i>System Administrator Guide</i> at www.xerox.com/office/3330docs.

Symptom	Solutions
<p>Toner smears or print comes off. The output has stains on the back side.</p> 	<ul style="list-style-type: none"> • Change the Paper Type settings in the print driver. For example, change Plain to Lightweight Cardstock. • In the Printing Preferences of the print driver, on the Paper/Output tab, change the Paper Type setting. • Verify that the paper is the correct size, type, and weight. If not, change the paper settings. • Verify that the printer is plugged into an outlet that is providing the correct voltage and power. Review the electrical specification of the printer with an electrician if necessary. • For details, refer to Electrical Specifications.
<p>Random spots on the output, or the image is blurry.</p> 	<ul style="list-style-type: none"> • Ensure that the toner cartridge is installed correctly. • If you used a non-genuine brand toner cartridge, install a genuine Xerox toner cartridge. • Use the Heavyweight or Cardstock paper type setting, or use paper type with a smoother surface. • Ensure that the humidity in the room is within specifications. For details, refer to Relative Humidity. • For details, refer to Selecting a Location for the Printer.
<p>The output is blank.</p> 	<p>Turn off the printer, then turn it on again. If the error persists, contact your Xerox representative.</p>

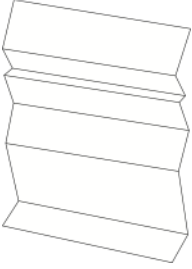
Symptom	Solutions
<p>Streaks appear in the output.</p> 	<p>Replace the Smart Kit Drum Cartridge. Contact your Xerox representative.</p>
<p>The output has a mottled appearance.</p> 	<ul style="list-style-type: none"> • Verify that the paper is the correct size, type, and weight. If not, change the paper settings. • Ensure that the humidity is within specifications. For details, refer to Selecting a Location for the Printer.
<p>Ghosting appears in the printed output.</p> 	<ul style="list-style-type: none"> • Verify that the paper is the correct size, type, and weight. If not, change the paper settings. • Change the Paper Type settings in the print driver. • In the Printing Preferences of the print driver, on the Paper/Output tab, change the Paper Type setting. • Replace the Drum Cartridge.
<p>Auger marks appear on the printed output.</p> 	<ul style="list-style-type: none"> • To check the toner level, check the control panel, use the print driver, or CentreWare Internet Services. If the toner cartridge is near empty, replace it. • Verify that the toner cartridge is approved for use in this printer, and replace it as needed. For best results, use a genuine Xerox toner cartridge. • Replace the Drum Cartridge.

Symptom	Solutions
<p>The output print is wrinkled or stained.</p> 	<ul style="list-style-type: none"> • Verify that the paper is the correct size, type, and weight for the printer and that it is loaded properly. If not, change the paper. • Try a new ream of paper. • Change the Paper Type settings in the print driver. • In the Printing Preferences of the print driver, on the Paper/Output tab, change the Paper Type setting.
<p>Envelopes are wrinkled or creased when printed.</p>	<ul style="list-style-type: none"> • Verify that envelopes are loaded properly in the bypass tray. • Follow the guidelines for printing on envelopes. For details, refer to Guidelines for Printing Envelopes.
<p>The top margin is incorrect.</p> 	<ul style="list-style-type: none"> • Verify that the paper is loaded properly. • Verify that the margins are set correctly in the application you are using.
<p>The printed surface of the paper is bumpy.</p> 	<ol style="list-style-type: none"> 1. Print a solid image over the entire surface of one sheet of paper. 2. Load the printed sheet into the tray with the printed side face down. 3. Print five blank pages to remove debris from the fuser rollers.

Getting Help

Xerox provides several automatic diagnostic utilities to help you maintain productivity and print quality.

Control Panel Messages

The printer control panel provides information and troubleshooting help. When a fault or warning condition occurs, the control panel displays a message informing you of the problem.

Available Information Pages

Information pages provide important details to help you troubleshoot issues or analyze printer use. You can print information pages from the printer control panel.

Information Page	Description
Configuration Report	The Configuration Report provides product information including, installed options, network settings, port setup, tray information, and more.
Supplies Usage Page	Shows information/life remaining status on Routing Maintenance Items.
Usage Profile	Lists Device information, Billing Meter information, and more.
PostScript Font List	List of installed internal fonts on printer.
PCL Font List	
Print All Above Reports	One touch to print all of the available Information pages.

For information on how to print information pages, refer to [Information Pages](#).

Accessing Available Information Pages

To access the Information Pages:

1. At the printer, press the **Menu** button.
2. Press the **Down** arrow button, and select **Information**.
3. Press the **Right** arrow button.
4. Press the **Down** arrow button, and select **Information Pages**.
5. Press the **Right** arrow button.

Online Support Assistant

The Online Support Assistant is a knowledge base that provides instructions and troubleshooting help to solve your printer problems. You can find solutions for print-quality problems, paper jams, software installation issues, and more.

To access the Online Support Assistant, go to www.xerox.com/office/3330support.

More Information

You can obtain more information about your printer from these sources:

Resource	Location
<i>Installation Guide</i>	Packaged with the printer.
Other documentation for your printer	www.xerox.com/office/3330docs
Technical support information for your printer; including online technical support, Online Support Assistant, and driver downloads.	www.xerox.com/office/3330support
Order supplies for your printer	www.xerox.com/office/3330supplies
A resource for tools and information, including interactive tutorials, printing templates, helpful tips, and customized features to meet your individual needs.	www.xerox.com/office/businessresourcecenter
Local sales and support center	www.xerox.com/office/worldcontacts
Printer registration	www.xerox.com/office/register
Xerox® Direct online store	www.direct.xerox.com/



Specifications

Printer Configurations and Options

Configurations

The WorkCentre® 3330 is a network printer and includes the following:

- Print
- 50-sheet bypass tray
- Tray 1 with 250-sheet capacity
- Optional Tray 2 with 550-sheet capacity

Standard Features

Print speed	Standard mode supports up to 42 ppm Letter
2-Sided print speed	Standard mode supports up to 21 ppm for Letter and 20 ppm for A4.
Print resolution	<ul style="list-style-type: none">• Standard print-quality mode: 600 x 600dpi• Enhanced print-quality mode: 1200 x 1200 dpi
Standard Memory (DRAM)	512 MB
Flash Memory (ROM)	128 MB
Paper capacity (80 g/20 lb.)	<ul style="list-style-type: none">• Bypass tray: 50-sheets• Tray 1: 250-sheets• Optional Tray 2: 550-sheets
Maximum print size	Legal (216 x 356 mm, 8.5 x 14 in.)
2-Sided Printing	Standard

Specifications

Control panel	Display and keypad navigation
Connectivity	<ul style="list-style-type: none">• Universal Serial Bus (USB 2.0)• USB Flash drive• Ethernet 10/100/1000 Base-T• Wireless• WiFi

Physical Specifications

Weights and Dimensions

	Standard Configuration with Tray 1 only	Standard Configuration with Tray 1 and Optional Tray 2
Width	37 cm (14.5 in.)	37 cm (14.5 in.)
Depth	37 cm (14.5 in.)	45.5 cm (17.9 in.)
Height	29 cm (11.4 in.)	43.4 cm (17.1 in.)
Weight	12.7 kg (28.0 lb.)	14.9 kg (32.1 lb.)

Clearance Requirements for Standard Configuration

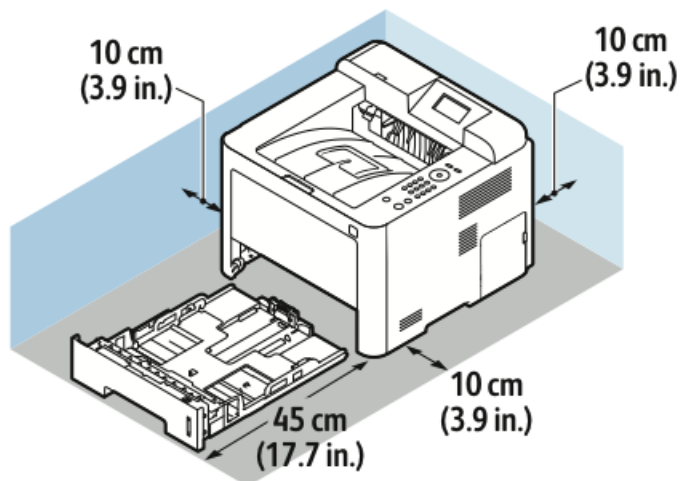

Environmental Specifications

Temperature

- Operating Temperature: 0–50°C (32–122°F)
- Storage Temperature: -25–85°C (-13–185°F)

Relative Humidity

Minimum–Maximum Humidity Range: 10–90 %, less than 90 % when in the packaging

- Optimum Humidity: 30–70 %
- Operating Humidity: 20–80 % Relative Humidity

Note

Under extreme environmental conditions, defects can occur due to condensation.

Elevation

For optimum performance, use the printer at elevations below 2500 m (8,202 ft.).

Electrical Specifications

Power Supply Voltage and Frequency

Power Supply Voltage	Power Supply Frequency
110–127 VAC +/-10 %, (99–135 VAC)	50 Hz 60 Hz
220–240 VAC +/-10 %, (198–264 VAC)	50 Hz 60 Hz

Power Consumption

- Energy Saver Mode (Sleep): Maximum 3.5 W
- Continuous printing: Maximum 700 W
- Ready/Standby: Maximum 50 W

This printer does not consume electric power when the power switch is turned off even if the printer is connected to an AC outlet.

Performance Specifications

Printer Warm-up Time

Less than 55 seconds from sleep mode.

Print Speed

Maximum print speeds for 1-sided continuous printing are 42 ppm for Letter (8.5 x 11 in.) and 40 ppm for A4 (210 x 297 mm).

Several factors affect print speed:

- 2-sided printing: The maximum print speeds for 2-sided continuous printing are 21 ppm for Letter (8.5 x 11 in.) and 20 ppm for A4 (210 x 297 mm).
- Print mode: Standard is the fastest print mode. Enhanced is half speed, or slower.
- Paper size: Letter (8.5 x 11 in.) and A4 (210 x 297 mm) sizes share the fastest print speed.
- Paper type: Plain paper prints faster than Cardstock or Heavyweight.
- Paper weight: Lightweight prints faster than heavier paper, such as Cardstock and Labels.

B

Regulatory Information

Basic Regulations

Xerox has tested this printer to electromagnetic emission and immunity standards. These standards are designed to mitigate interference caused or received by this printer in a typical office environment.

ENERGY STAR® Qualified Product



The Phaser® 3330 is ENERGY STAR® qualified under the ENERGY STAR Program Requirements for Imaging Equipment.

The ENERGY STAR and ENERGY STAR mark are registered United States trademarks. The ENERGY STAR Imaging Equipment Program is a team effort between the United States, European Union, and Japanese governments and the office equipment industry to promote energy-efficient copiers, printers, fax, multifunction printers, personal computers, and monitors. Reducing product energy consumption helps combat smog, acid rain, and long-term changes to the climate by decreasing the emissions that result from generating electricity.

Xerox ENERGY STAR equipment is preset at the factory. Your printer is delivered with the timer, for switching to Power Saver Mode from the last copy/print out, set at 1 or 2 minutes. A more detailed description of this feature can be found in the [Power Saver](#) section of this guide.

United States FCC Regulations

This equipment has been tested and found to comply with the limits for a Class B digital device, pursuant to Part 15 of the FCC Rules. These limits are designed to provide reasonable protection against harmful interference when the equipment is operated in a commercial environment. This equipment generates, uses, and can radiate radio frequency energy. If it is not installed and used in accordance with these instructions, it may cause harmful interference to radio communications. Operation of this equipment in a residential area is likely to cause harmful interference in which case the user will be required to correct the interference at his/her own expense.

Regulatory Information

If this equipment does cause harmful interference to radio or television reception, which can be determined by turning the equipment off and on, the user is encouraged to try to correct the interference by one or more of the following measures:

- Reorient or relocate the receiving antenna.
- Increase the separation between the equipment and receiver.
- Connect the equipment into an outlet on a circuit different from that to which the receiver is connected.
- Consult the dealer or an experienced radio/TV technician for help.

Changes or modifications to this equipment not approved by Xerox can void the authority of the user to operate this equipment.

Note

To ensure compliance with Part 15 of the FCC rules, use shielded interface cables.

Canada

This Class B digital apparatus complies with Canadian ICES-003.

Cet appareil numérique de la classe B est conforme à la norme NMB-003 du Canada.

European Union



The CE mark applied to this product symbolizes a declaration of conformity by Xerox with the following applicable Directives of the European Union as of the dates indicated:

- February 26, 2014: Low Voltage Directive 2014/35/EU
- February 26, 2014: Electromagnetic Compatibility Directive 2014/30/EU
- March 9, 1999: Radio & Telecommunications Terminal Equipment Directive 1999/5/EC

This printer, if used properly in accordance with the instructions, is not dangerous for the consumer or for the environment.

To ensure compliance with European Union regulations, use shielded interface cables.

A signed copy of the Declaration of Conformity for this printer can be obtained from Xerox.

European Union Lot 4 Imaging Equipment Agreement Environmental Information

Environmental Information Providing Environmental Solutions and Reducing Cost

The following information has been developed to assist users and has been issued in relation to the European Union (EU) Energy Related Products Directive, specifically the Lot 4 study on Imaging Equipment. This requires manufacturers to improve environmental performance of in scope products and supports the EU action plan on energy efficiency.

In scope products are Household and Office equipment that meet the following criteria.

- Standard monochrome format products with a maximum speed less than 66 A4 images per minute
- Standard color format products with a maximum speed less than 51 A4 images per minute

Introduction

The following information has been developed to assist users and has been issued in relation to the European Union (EU) Energy Related Products Directive, specifically the Lot 4 study on Imaging Equipment. This requires manufacturers to improve environmental performance of in scope products and supports the EU action plan on energy efficiency.

In scope products are Household and Office equipment that meet the following criteria.

- Standard monochrome format products with a maximum speed less than 66 A4 images per minute
- Standard color format products with a maximum speed less than 51 A4 images per minute

Environmental Benefits of Duplex Printing

Most Xerox products have duplex printing, also known as 2-sided printing, capability. This enables you to print on both sides of the paper automatically, and therefore helps to reduce the use of valuable resources by reducing your paper consumption. The Lot 4 Imaging Equipment agreement requires that on models greater than or equal to 40 ppm color or greater than or equal to 45 ppm monochrome the duplex function has been auto enabled, during the setup and driver installation. Some Xerox models below these speed bands may also be enabled with 2-sided printing settings defaulted on at the time of install. Continuing to use the duplex function will reduce the environmental impact of your work. However, should you require simplex/1-sided printing, you may change the print settings in the print driver.

Paper Types

This product can be used to print on both recycled and virgin paper, approved to an environmental stewardship scheme, which complies with EN12281 or a similar quality standard. Lighter weight paper (60 g/m²), which contains less raw material and thus save resources per print, may be used in certain applications. We encourage you to check if this is suitable for your printing needs.

ENERGY STAR (European Union Information)

The ENERGY STAR program is a voluntary scheme to promote the development and purchase of energy efficient models, which help to reduce environmental impact. Details on the ENERGY STAR program and models qualified to ENERGY STAR can be found at the following website: www.energystar.gov/find_a_product

Power Consumption and Activation Time

The amount of electricity a product consumes depends on the way the device is used. This product is designed and configured to enable you to reduce your electricity costs. After the last print, the device switches to Ready mode. In this mode, the device can print again immediately. If the product is not used for a period of time, the device switches to a Power Saver mode. In these modes, to enable reduced product power consumption, only essential functions remain active.

The product takes slightly longer to produce the first print after it exits Power Saver mode than it takes in Ready mode. This delay is the result of the system waking up from Power Saver mode and is typical of most imaging products on the market.

You can set a longer activation time or completely deactivate the Power Saver mode. This device can take longer to switch to a lower energy level.

To learn more about Xerox participation in sustainability initiatives, go to: www.xerox.com/about-xerox/environment/enus.html.

Environmental Choice Certified to Office Machines CCD-035



This product is certified to Environmental Choice standard for office machines, meeting all requirements for reduced environmental impact. As part of achieving certification, Xerox Corporation has proven this product meets the Environmental Choice criteria for energy efficiency. Certified copier, printer, multifunctional device, and fax products must also meet criteria such as reduced chemical emissions and demonstrate compatibility with recycled supplies. Environmental Choice was established in 1988 to help consumers find products and services with reduced environmental impacts. Environmental Choice is a voluntary, multi-attribute, and lifecycle-based environmental certification. This certification indicates that a product has undergone rigorous scientific testing, exhaustive auditing, or both, to prove its compliance with stringent, third-party, environmental performance standards.

Germany

Germany - Blue Angel



RAL, the German Institute for Quality Assurance and Labeling, has awarded this device the Blue Angel Environmental Label. This label distinguishes it as a device that satisfies Blue Angel criteria for environmental acceptability in terms of device design, manufacture, and operation. For more information, go to: www.blauer-engel.de.

Blendschutz

Das Gerät ist nicht für die Benutzung im unmittelbaren Gesichtsfeld am Bildschirmarbeitsplatz vorgesehen. Um störende Reflexionen am Bildschirmarbeitsplatz zu vermeiden, darf dieses Produkt nicht im unmittelbaren Gesichtsfeld platziert werden.

Lärmemission

Maschinenlärminformations-Verordnung 3. GPSGV: Der höchste Schalldruckpegel beträgt 70 dB(A) oder weniger gemäß EN ISO 7779.

Importeur

Xerox GmbH

Hellersbergstraße 2-4

41460 Neuss

Deutschland

Turkey RoHS Regulation

In compliance with Article 7 (d), we hereby certify “it is in compliance with the EERegulation.”

“EEE yönetmeliğine uygundur.”

Regulatory Information for 2.4 GHz Wireless Network Adapter

This product contains a 2.4-GHz Wireless LAN radio transmitter module which complies with the requirements specified in FCC Part 15, Industry Canada RSS-210 and European Council Directive 99/5/EC.

Operation of this device is subject to the following two conditions: (1) this device may not cause harmful interference, and (2) this device must accept any interference received, including interference that may cause undesired operation.

Changes or modifications to this device not specifically approved by the Xerox Corporation may void the user's authority to operate this equipment.

Material Safety Data Sheets

For Material Safety Data information regarding your printer, go to:

- North America: www.xerox.com/msds
- European Union: www.xerox.com/environment_europe

For the Customer Support Center phone numbers, go to www.xerox.com/office/worldcontacts.



Recycling and Disposal

All Countries

If you are managing the disposal of your Xerox product, please note that the printer may contain lead, mercury, perchlorate, and other materials whose disposal may be regulated due to environmental considerations. The presence of these materials is fully consistent with global regulations applicable at the time that the product was placed on the market. For recycling and disposal information, contact your local authorities. Perchlorate Material: This product may contain one or more Perchlorate-containing devices, such as batteries. Special handling may apply, please see www.dtsc.ca.gov/hazardouswaste/perchlorate.

North America

Xerox operates an equipment take-back and reuse/recycle program. Contact your Xerox representative (1-800-ASK-XEROX) to determine if this Xerox product is part of the program. For more information about Xerox environmental programs, visit www.xerox.com/environment, or for recycling and disposal information, contact your local authorities.

European Union

Some equipment may be used in both a domestic/household and a professional/business application.

Domestic/Household Environment



Application of this symbol on your equipment is confirmation that you should not dispose of the equipment in the normal household waste stream.

Recycling and Disposal

In accordance with European legislation, end-of-life electrical and electronic equipment subject to disposal must be segregated from household waste.

Private households within EU member states may return used electrical and electronic equipment to designated collection facilities free of charge. Please contact your local disposal authority for information.

In some member states, when you purchase new equipment, your local retailer may be required to take back your old equipment free of charge. Please ask your retailer for information.

Professional/Business Environment



Application of this symbol on your equipment is confirmation that you must dispose of this equipment in compliance with agreed national procedures.

In accordance with European legislation, end-of-life electrical and electronic equipment subject to disposal must be managed within agreed procedures.

Prior to disposal, please contact your local reseller or Xerox representative for end-of-life take-back information.

Collection and Disposal of Equipment and Batteries



- These symbols on the products and/or accompanying documents mean that used electrical and electronic products and batteries should not be mixed with general household waste.
- For proper treatment, recovery, and recycling of old products and used batteries, please take them to applicable collection points, in accordance with your national legislation and the Directive 2002/96/EC and 2006/66/EC.
- By disposing of these products and batteries correctly, you will help to save valuable resources and prevent any potential negative effects on human health and the environment which could otherwise arise from inappropriate waste handling.
- For more information about collection and recycling of old products and batteries, please contact your local municipality, your waste disposal service, or the point of sale where you purchased the items.
- Penalties may be applicable for incorrect disposal of this waste, in accordance with national legislation.

Business Users in the European Union

If you wish to discard electrical and electronic equipment, please contact your dealer or supplier for further information.

Disposal Outside of the European Union

These symbols are only valid in the European Union. If you wish to discard these items, please contact your local authorities or dealer and ask for the correct method of disposal.

Battery Symbol Note



This wheeled-bin symbol may be used in combination with a chemical symbol. This establishes compliance with the requirements set out by the Directive.

Battery Removal

Batteries should only be replaced by a manufacturer-approved service facility.

Other Countries

Please contact your local waste management authority to request disposal guidance.

