



# ThinkSystem SN550 Compute Node Setup Guide



**Machine Type: 7X16**

## **Note**

Before using this information and the product it supports, be sure to read and understand the safety information and the safety instructions, which are available at:

[http://thinksystem.lenovofiles.com/help/topic/safety\\_documentation/pdf\\_files.html](http://thinksystem.lenovofiles.com/help/topic/safety_documentation/pdf_files.html)

In addition, be sure that you are familiar with the terms and conditions of the Lenovo warranty for your server, which can be found at:

<http://datacentersupport.lenovo.com/warrantylookup>

**Second Edition (September 2017)**

**© Copyright Lenovo 2017.**

**LIMITED AND RESTRICTED RIGHTS NOTICE: If data or software is delivered pursuant to a General Services Administration "GSA" contract, use, reproduction, or disclosure is subject to restrictions set forth in Contract No. GS-35F-05925**

---

# Contents

## **Safety . . . . . iii**

Safety inspection checklist . . . . . iv

## **Chapter 1. Introduction . . . . . 1**

Compute node package contents . . . . . 3

Features . . . . . 3

Specifications . . . . . 5

    Particulate contamination . . . . . 7

Management options . . . . . 8

## **Chapter 2. Compute node components . . . . . 15**

Power, controls, and indicators . . . . . 15

    Compute node controls, connectors, and LEDs . . . . . 15

    Light path diagnostics . . . . . 17

KVM cable . . . . . 19

System-board layout . . . . . 19

    System-board connectors . . . . . 19

    System-board switches . . . . . 20

Parts list . . . . . 22

## **Chapter 3. Compute node hardware setup . . . . . 25**

Compute node setup checklist . . . . . 25

Installation Guidelines . . . . . 26

    System reliability guidelines . . . . . 27

    Working inside the server with the power on . . . . . 27

    Handling static-sensitive devices . . . . . 28

Install compute node hardware options . . . . . 28

    Remove the top cover . . . . . 29

    Remove the air baffle . . . . . 30

    Remove the 2.5-inch drive backplane . . . . . 31

    Remove the RAID adapter . . . . . 32

    Install a 2.5-inch drive backplane . . . . . 33

    Install a 2.5-inch hot-swap drive . . . . . 34

    Install a DIMM . . . . . 35

    Install the flash power module . . . . . 38

    Install an I/O expansion adapter . . . . . 39

    Install the M.2 backplane . . . . . 42

    Install an M.2 drive . . . . . 43

    Install a processor-heat-sink module . . . . . 47

    Install a RAID adapter . . . . . 49

    Install the air baffle . . . . . 52

    Install the compute node cover . . . . . 52

Install the compute node in the chassis . . . . . 54

Power on the compute node . . . . . 55

Validate compute node setup . . . . . 56

Power off the compute node . . . . . 56

## **Chapter 4. System configuration . . . . . 59**

Set the network connection for the Lenovo XClarity Controller . . . . . 59

Update the firmware . . . . . 60

Configure the firmware . . . . . 62

    DIMM configuration . . . . . 63

    RAID configuration . . . . . 67

Install the operating system . . . . . 67

Back up the compute node configuration . . . . . 68

## **Chapter 5. Resolving installation issues . . . . . 69**

## **Appendix A. Getting help and technical assistance . . . . . 73**

Before you call . . . . . 73

Collecting service data . . . . . 74

Contacting Support . . . . . 75

## **Index . . . . . 77**



---

# Safety

Before installing this product, read the Safety Information.

قبل تركيب هذا المنتج، يجب قراءة الملاحظات الأمنية

Antes de instalar este produto, leia as Informações de Segurança.

在安装本产品之前，请仔细阅读 **Safety Information** (安全信息)。

安裝本產品之前，請先閱讀「安全資訊」。

Prije instalacije ovog produkta obavezno pročitajte Sigurnosne Upute.

Před instalací tohoto produktu si přečtěte příručku bezpečnostních instrukcí.

Læs sikkerhedsforskrifterne, før du installerer dette produkt.

Lees voordat u dit product installeert eerst de veiligheidsvoorschriften.

Ennen kuin asennat tämän tuotteen, lue turvaohjeet kohdasta Safety Information.

Avant d'installer ce produit, lisez les consignes de sécurité.

Vor der Installation dieses Produkts die Sicherheitshinweise lesen.

Πριν εγκαταστήσετε το προϊόν αυτό, διαβάστε τις πληροφορίες ασφάλειας (safety information).

לפני שתתקינו מוצר זה, קראו את הוראות הבטיחות.

A termék telepítése előtt olvassa el a Biztonsági előírásokat!

Prima di installare questo prodotto, leggere le Informazioni sulla Sicurezza.

製品の設置の前に、安全情報をお読みください。

본 제품을 설치하기 전에 안전 정보를 읽으십시오.

Пред да се инсталира овој продукт, прочитајте информацијата за безбедност.

பெரிய அளவு  
பெரிய அளவு  
பெரிய அளவு  
பெரிய அளவு  
பெரிய அளவு  
பெரிய அளவு  
பெரிய அளவு  
பெரிய அளவு  
பெரிய அளவு  
பெரிய அளவு

Les sikkerhetsinformasjonen (Safety Information) før du installerer dette produktet.

Przed zainstalowaniem tego produktu, należy zapoznać się z książką "Informacje dotyczące bezpieczeństwa" (Safety Information).

Antes de instalar este produto, leia as Informações sobre Segurança.

Перед установкой продукта прочтите инструкции по технике безопасности.

Pred inštaláciou tohto zariadenia si pečítajte Bezpečnostné predpisy.

Pred namestitvijo tega proizvoda preberite Varnostne informacije.

Antes de instalar este producto, lea la información de seguridad.

Läs säkerhetsinformationen innan du installerar den här produkten.

ཐོན་ཁུངས་འདི་བདེ་སྤྱོད་མ་བྱས་གོང་། རྒྱུ་རྒྱུ་ཡིད་གཟབ་  
བྱ་འདྲ་མིན་ཡོད་པའི་འོད་ཟེར་བལྟ་དགོས།

Bu ürünü kurmadan önce güvenlik bilgilerini okuyun.

مەزكۇر مەھسۇلاتنى ئورنىتىشتىن بۇرۇن بىخەتەرلىك ئۇچۇرلىرىنى ئوقۇپ چىقىڭ.

Youq mwngz yungh canjbinj neix gaxgonq, itdingh aeu doeg aen  
canjbinj soengq cungj vahgangj ancien siusik.

---

## Safety inspection checklist

Use the information in this section to identify potentially unsafe conditions with your server. As each machine was designed and built, required safety items were installed to protect users and service technicians from injury.

**Important:** Electrical grounding of the server is required for operator safety and correct system function. Proper grounding of the electrical outlet can be verified by a certified electrician.

Use the following checklist to verify that there are no potentially unsafe conditions:

1. Make sure that the power is off and the power cord is disconnected.
2. Check the power cord.
  - Make sure that the third-wire ground connector is in good condition. Use a meter to measure third-wire ground continuity for 0.1 ohm or less between the external ground pin and the frame ground.
  - Make sure that the power cord is the correct type.  
To view the power cords that are available for the server:
    - a. Go to:  
<http://lesc.lenovo.com>
    - b. In the Customize a Model pane:
      - 1) Click **Select Options/Parts for a Model**.
      - 2) Enter the machine type and model for your server.
    - c. Click the Power tab to see all line cords.
  - Make sure that the insulation is not frayed or worn.
3. Check for any obvious non-Lenovo alterations. Use good judgment as to the safety of any non-Lenovo alterations.
4. Check inside the server for any obvious unsafe conditions, such as metal filings, contamination, water or other liquid, or signs of fire or smoke damage.
5. Check for worn, frayed, or pinched cables.

6. Make sure that the power-supply cover fasteners (screws or rivets) have not been removed or tampered with.





---

## Chapter 1. Introduction

Each ThinkSystem SN550 compute node supports up to two 2.5-inch hot-swap Serial Attached SCSI (SAS), Serial ATA (SATA) or Non-Volatile Memory express (NVMe) drives.

When you receive your Lenovo ThinkSystem SN550 Type 7X16 compute node, refer to the *Setup Guide* to set up the compute node, install optional devices, and perform the initial configuration of the compute node. Meanwhile, the *Maintenance Manual* contains information to help you solve problems that might occur in your Lenovo ThinkSystem SN550 Type 7X16 compute node. It describes the diagnostic tools that come with the compute node, error codes and suggested actions, and instructions for replacing failing components.

The compute node comes with a limited warranty. For details about the warranty, see:  
<https://datacentersupport.lenovo.com/us/en/documents/ht100742>

For details about your specific warranty, see:  
<http://datacentersupport.lenovo.com/warrantylookup>

### Notes:

1. The first generation Chassis Management Module (CMM1; 68Y7030) is not supported by the ThinkSystem SN550 compute node.
2. The second generation Chassis Management Module (CMM2; 00FJ669) must be at firmware level 1.6.1 or above to support the ThinkSystem SN550 compute node. This applies to both CMMs that are installed in the chassis.
3. The illustrations in this document might differ slightly from your model.

### Identifying your compute node

When you contact Lenovo for help, the machine type, model, and serial number information helps support technicians to identify your compute node and provide faster service.

Record information about the compute node in the following table.

*Table 1. Record of the system information*

Product name	Machine Type (s)	Model number	Serial number
Lenovo ThinkSystem SN550 Type 7X16	7X16		

The model number and serial number are on the ID label on the front of the compute node and the chassis, as shown in the following illustration.

**Note:** The illustrations in this document might differ slightly from your hardware.

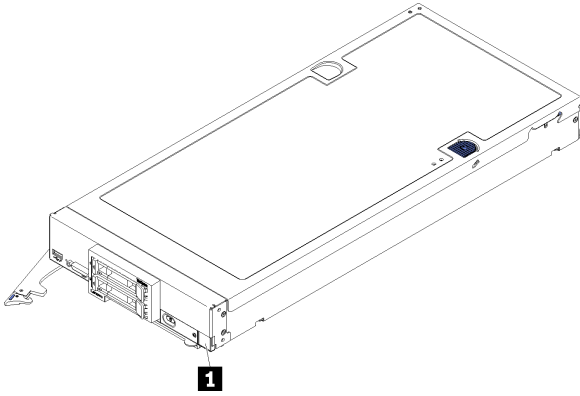

Figure 1. ID label on the front of the node

**1** ID label

**Customer information tabs**

The customer information tabs contain system-related information such as firmware level, administrator accounts and so forth.

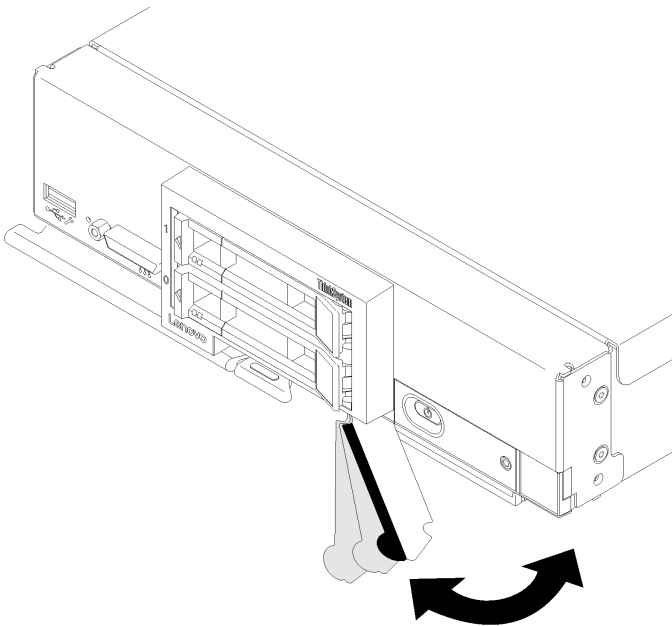

Figure 2. Location of customer information tabs

The system service label, which is on the cover of the compute node, provides a quick response (QR) code for mobile access to service information. You can scan the QR code using a QR code reader and scanner with a mobile device and get quick access to the Lenovo Service Information website. The Lenovo Service Information website provides additional information for parts installation and replacement videos, and error codes for server support.

The following illustration shows the QR code (<https://support.lenovo.com/p/servers/sn550>.)



Figure 3. QR code

---

## Compute node package contents

When you receive your compute node, verify that the shipment contains everything that you expected to receive.

The compute node package includes the following items:

- Compute node
- Printed documentation

---

## Features

Performance, ease of use, reliability, and expansion capabilities were key considerations in the design of the compute node. These design features make it possible for you to customize the system hardware to meet your needs today and provide flexible expansion capabilities for the future.

Your compute node implements the following features and technologies:

- **Features on Demand**

If a Features on Demand feature is integrated in the compute node or in an optional device that is installed in the compute node, you can purchase an activation key to activate the feature. For information about Features on Demand, see <https://fod.lenovo.com/lkms>.

- **Lenovo XClarity Controller**

The Lenovo XClarity Controller is the common management controller for Lenovo ThinkSystem compute node hardware. The Lenovo XClarity Controller consolidates multiple management functions in a single chip on the compute node system board.

Some of the features that are unique to the Lenovo XClarity Controller are enhanced performance, higher-resolution remote video, and expanded security options. For additional information about the Lenovo XClarity Controller, see [http://sysmgt.lenovofiles.com/help/topic/com.lenovo.systems.management.xcc.doc/product\\_page.html](http://sysmgt.lenovofiles.com/help/topic/com.lenovo.systems.management.xcc.doc/product_page.html).

- **UEFI-compliant server firmware**

Lenovo ThinkSystem firmware is Unified Extensible Firmware Interface (UEFI) 2.5 compliant. UEFI replaces BIOS and defines a standard interface between the operating system, platform firmware, and external devices.

Lenovo ThinkSystem servers are capable of booting UEFI-compliant operating systems, BIOS-based operating systems, and BIOS-based adapters as well as UEFI-compliant adapters.

**Note:** The server does not support DOS (Disk Operating System).

- **Large system-memory capacity**

The compute node supports up to a maximum of 1.5 TB of system memory. The compute node supports only industry-standard double-data-rate 4 DIMM (DDR4), registered DIMM (RDIMM), or load-reduced DIMM (LRDIMM).

- **Flexible network support**

The compute node has connectors on the system board for optional expansion adapters for adding network communication capabilities to the compute node. You can install up to two I/O expansion adapters for network support. This provides the flexibility to install expansion adapters that support a variety of network communication technologies.

- **Integrated Trusted Platform Module (TPM)**

This integrated security chip performs cryptographic functions and stores private and public secure keys. It provides the hardware support for the Trusted Computing Group (TCG) specification. You can download the software to support the TCG specification, when the software is available.

**Note:** For customers in the People's Republic of China, TPM is not supported. However, customers in the People's Republic of China can install a Trusted Cryptographic Module (TCM) adapter (sometimes called a daughter card).

- **Drive support**

The compute node supports up to two hot-swap drives. You can implement RAID 0 or RAID 1 for the drives. Additional drive types and RAID levels are supported when an optional drive backplane and RAID adapter are installed.

- **Light path diagnostics**

Light path diagnostics provides light-emitting diodes (LEDs) to help you diagnose problems.

- **Mobile access to Lenovo Service Information website**

The compute node provides a quick response (QR) code on the system service label, which is on the cover of the compute node, that you can scan using a QR code reader and scanner with a mobile device to get quick access to the Lenovo Service Information website. The Lenovo Service Information website provides additional information for parts installation and replacement videos, and error codes for compute node support. Information about the ThinkSystem SN550 QR code can be found here: Chapter 1 "Introduction" on page 1.

- **Processor technology**

The compute node supports up to two multi-core Intel Xeon processors.

**Note:** The optional processors that Lenovo supports are limited by the capacity and capability of the compute node. Any processor that you install must have the same specifications as the processor that came with the compute node.

- **Power throttling**

By enforcing a power policy known as power-domain oversubscription, the Lenovo Flex System chassis can share the power load between two or more power supply modules to ensure sufficient power for each device in the Lenovo Flex System chassis. This policy is enforced when the initial power is applied to the Lenovo Flex System chassis or when a compute node is inserted into the Lenovo Flex System chassis.

The following settings for this policy are available:

- Basic power management
- Power module redundancy
- Power module redundancy with compute node throttling allowed

You can configure and monitor the power environment by using the Chassis Management Module. For more information, see the Flex System Chassis Management Module: Command-Line Interface Reference Guide at [http://flexsystem.lenovofiles.com/help/topic/com.lenovo.acc.cmm.doc/dw1kt\\_cmm\\_cli\\_book.pdf](http://flexsystem.lenovofiles.com/help/topic/com.lenovo.acc.cmm.doc/dw1kt_cmm_cli_book.pdf).

- **Lenovo XClarity Administrator**

Lenovo XClarity Administrator is a centralized resource-management solution that enables administrators to deploy infrastructure faster and with less effort. The solution seamlessly integrates into ThinkSystem

compute nodes, and NeXtScale compute nodes, as well as the Flex System converged infrastructure platform.

Lenovo XClarity Administrator provides:

- Automated discovery
- Agent-free hardware management
- Monitoring
- Firmware updates and compliance
- Pattern-based configuration management
- Deployment of operating systems and hypervisors

Administrators are able to find the right information and accomplish critical tasks faster through an uncluttered, dashboard-driven graphical user interface (GUI). Centralizing and automating foundational infrastructure deployment and lifecycle management tasks across large pools of systems frees up administrator time, and makes resources available to end-users faster.

Lenovo XClarity is easily extended into the leading virtualization management platforms from Microsoft and VMware using software plug-ins, called Lenovo XClarity Integrators. The solution improves workload uptime and service-level assurance by dynamically relocating workloads from affected hosts in the cluster during rolling compute node reboots or firmware updates, or during predicted hardware failures.

For more information about Lenovo XClarity Administrator, see the <http://shop.lenovo.com/us/en/systems/software/systems-management/xclarity/> and the <http://flexsystem.lenovofiles.com/help/index.jsp>.

- **Systems-management support**

The compute node XClarity Controller provides a web interface for remote systems-management support. You can use the interface to view system status and to control systems-management functions and baseboard management settings.

The XClarity Controller communicates with the Lenovo Flex System Chassis Management Module (CMM) and the Lenovo XClarity Administrator application (if installed).

- The CMM is a hot-swap module that provides systems-management functions for all components in an Lenovo Flex System chassis. It controls a serial port for remote connection and a 1 Gbps Ethernet remote-management connection. For more information, see the Flex System Chassis Management Module: Command-Line Interface Reference Guide at [http://flexsystem.lenovofiles.com/help/topic/com.lenovo.acc.cmm.doc/dw1kt\\_cmm\\_cli\\_book.pdf](http://flexsystem.lenovofiles.com/help/topic/com.lenovo.acc.cmm.doc/dw1kt_cmm_cli_book.pdf).
- The Lenovo XClarity Administrator is a virtual appliance that you can use to manage Lenovo Flex System chassis in a secure environment. The Lenovo XClarity Administrator provides a central interface to perform the following functions for all managed endpoints:
  - User management
  - Hardware monitoring and management
  - Configuration management
  - Operating system deployment
  - Firmware management

For more information, see

<https://support.lenovo.com/us/en/documents/LNVO-XCLARIT>.

---

## Specifications

The following information is a summary of the features and specifications of the compute node. Depending on the model, some features might not be available, or some specifications might not apply.

Table 2. Specifications

Specification	Description
Size	<ul style="list-style-type: none"> <li>• Height: 55.5 mm (2.2 in)</li> <li>• Depth: 492.7 mm (19.4 in)</li> <li>• Width: 215.5 mm (8.5 in)</li> </ul>
Weight	Approximately 4.7 kg (10.4 lb) to 7.0 kg (15.5 lb), depending on your configuration.
Processor (depending on the model)	<p>Processor: Up to two multi-core Intel Xeon processors.</p> <p><b>Note:</b> Use the Setup utility to determine the type and speed of the processors in the compute node.</p> <p>For a list of supported processors, see: <a href="http://www.lenovo.com/serverproven/">http://www.lenovo.com/serverproven/</a></p>
Memory	<ul style="list-style-type: none"> <li>• 24 dual inline memory module (DIMM) connectors</li> <li>• Type: Low-profile (LP) double-data rate (DDR4) DRAM</li> <li>• Supports 8 GB, 16 GB, 32 GB and 64 GB DIMMs with up to 1.5 TB of total memory on the system board.</li> </ul> <p><b>Note:</b> Future support is planned for the 128GB 3DS RDIMM. The total memory on the system board may reach up to 3TB.</p> <ul style="list-style-type: none"> <li>• Support for RDIMMs and LRDIMMs (combining is not supported)</li> </ul>
2.5-inch drive/backplane	<ul style="list-style-type: none"> <li>• Supports up to two small form factor (SFF) drive bays. Drive bay can be either SATA only, SAS/SATA, or NVMe/SATA, depending on the model.</li> <li>• Supported 2.5-inch drives: <ul style="list-style-type: none"> <li>– Serial Attached SCSI (SAS)/Serial Advanced Technology Attachment (SATA) hot-swap hard disk drives/solid-state drives</li> <li>– Non-Volatile Memory Express (NVMe) solid-state drives</li> </ul> </li> </ul>
M.2 drive/backplane	<p>ThinkSystem M.2 with Mirroring Enablement Kit contains dual M.2 backplane supports up to two identical M.2 drives.</p> <p>Supports 3 different physical sizes of M.2 drives:</p> <ul style="list-style-type: none"> <li>• 42 mm (2242)</li> <li>• 60 mm (2260)</li> <li>• 80 mm (2280)</li> </ul>
RAID adapter	<ul style="list-style-type: none"> <li>• RAID 530-4i adapter</li> <li>• RAID 930-4i-2GB adapter</li> </ul>
Integrated functions	<ul style="list-style-type: none"> <li>• One baseboard management controller (BMC) with integrated VGA controller (XClarity Controller or XCC)</li> <li>• Light path diagnostics</li> <li>• Automatic server restart (ASR)</li> <li>• Additional RAID levels supported when an optional RAID controller is installed</li> <li>• One external USB 3.0 port</li> <li>• Serial over LAN (SOL)</li> <li>• Wake on LAN (WOL) when an optional I/O adapter with WOL capability is installed.</li> </ul>
Predictive failure analysis (PFA) alerts	<ul style="list-style-type: none"> <li>• Processors</li> <li>• Memory</li> <li>• Drives</li> </ul>

Table 2. Specifications (continued)

Specification	Description
Security	Fully compliant with NIST 800-131A. The security cryptography mode set by the managing device (CMM or Lenovo XClarity Administrator) determines the security mode in which the compute node operates.
Environment	<p>The ThinkSystem SN550 compute node complies with ASHRAE Class A2 specifications. Depending on the hardware configuration, some models comply with ASHRAE Class A3 specifications. System performance may be impacted when operating temperature is outside ASHRAE A2 specification or fan failed condition. The Lenovo ThinkSystem SN550 compute node is supported in the following environment:</p> <ul style="list-style-type: none"> <li>• Air temperature: <ul style="list-style-type: none"> <li>– Operating: <ul style="list-style-type: none"> <li>– ASHRAE Class A2: 10 °C - 35 °C (50 °F - 95 °F); decrease the maximum ambient temperature by 1 °C for every 300 m (984 ft) increase in altitude above 900 m (2,953 ft)</li> <li>– ASHRAE Class A3: 5 °C - 40 °C (41 °F - 104 °F); decrease the maximum ambient temperature by 1 °C for every 175 m (574 ft) increase in altitude above 900 m (2,953 ft)</li> </ul> </li> <li>– Compute node off: 5°C to 45°C (41°F to 113°F)</li> <li>– Shipment/Storage: -40 °C to 60 °C (-40 °F to 140 °F)</li> </ul> </li> <li>• Maximum altitude: 3,050 m (10,000 ft)</li> <li>• Relative Humidity (non-condensing): <ul style="list-style-type: none"> <li>– Operating: <ul style="list-style-type: none"> <li>– ASHRAE Class A2: 8% - 80%, maximum dew point: 21°C (70°F)</li> <li>– ASHRAE Class A3: 8% - 85%, maximum dew point: 24°C (75°F)</li> </ul> </li> <li>– Shipment/Storage: 8% - 90%</li> </ul> </li> <li>• Particulate contamination</li> </ul> <p><b>Attention:</b> Airborne particulates and reactive gases acting alone or in combination with other environmental factors such as humidity or temperature might pose a risk to the server. For information about the limits for particulates and gases, see “Particulate contamination” on page 7.</p>

**Notes:** Future support is planned for the single M.2 backplane function in the UEFI Setup page. Currently, users are unable to enable this functionality. This functionality is found in the following paths in the UEFI setup page.

- **F1 Setup → System Settings → Device and I/O Ports → Enable/Disable Onboard Device(s)**
- **F1 Setup → System Settings → Device and I/O Ports → Enable/Disable Adapter Option ROM Support**
- **F1 Setup → System Settings → Device and I/O Ports → Set Option ROM Execution Order**

## Particulate contamination

**Attention:** Airborne particulates (including metal flakes or particles) and reactive gases acting alone or in combination with other environmental factors such as humidity or temperature might pose a risk to the device that is described in this document.

Risks that are posed by the presence of excessive particulate levels or concentrations of harmful gases include damage that might cause the device to malfunction or cease functioning altogether. This specification sets forth limits for particulates and gases that are intended to avoid such damage. The limits must not be viewed or used as definitive limits, because numerous other factors, such as temperature or moisture content of the air, can influence the impact of particulates or environmental corrosives and gaseous contaminant transfer. In the absence of specific limits that are set forth in this document, you must implement practices that maintain particulate and gas levels that are consistent with the protection of human

health and safety. If Lenovo determines that the levels of particulates or gases in your environment have caused damage to the device, Lenovo may condition provision of repair or replacement of devices or parts on implementation of appropriate remedial measures to mitigate such environmental contamination. Implementation of such remedial measures is a customer responsibility.

Table 3. Limits for particulates and gases

Contaminant	Limits
Particulate	<ul style="list-style-type: none"> <li>The room air must be continuously filtered with 40% atmospheric dust spot efficiency (MERV 9) according to ASHRAE Standard 52.2<sup>1</sup>.</li> <li>Air that enters a data center must be filtered to 99.97% efficiency or greater, using high-efficiency particulate air (HEPA) filters that meet MIL-STD-282.</li> <li>The deliquescent relative humidity of the particulate contamination must be more than 60%<sup>2</sup>.</li> <li>The room must be free of conductive contamination such as zinc whiskers.</li> </ul>
Gaseous	<ul style="list-style-type: none"> <li>Copper: Class G1 as per ANSI/ISA 71.04-1985<sup>3</sup></li> <li>Silver: Corrosion rate of less than 300 Å in 30 days</li> </ul>
<p><sup>1</sup> ASHRAE 52.2-2008 - <i>Method of Testing General Ventilation Air-Cleaning Devices for Removal Efficiency by Particle Size</i>. Atlanta: American Society of Heating, Refrigerating and Air-Conditioning Engineers, Inc.</p> <p><sup>2</sup> The deliquescent relative humidity of particulate contamination is the relative humidity at which the dust absorbs enough water to become wet and promote ionic conduction.</p> <p><sup>3</sup> ANSI/ISA-71.04-1985. <i>Environmental conditions for process measurement and control systems: Airborne contaminants</i>. Instrument Society of America, Research Triangle Park, North Carolina, U.S.A.</p>	

## Management options

Several management interfaces are available for managing your server. The management options described in this section are provided to support the direct management of Lenovo servers.

In addition to the tools described in the following table, you can use the Chassis Management Module (CMM) to manage all devices in a Flex System chassis, including the ThinkSystem compute nodes. The CMM provides system-management functions for all components in a Lenovo Flex System Enterprise Chassis. It controls a serial port for connection to a local console or a serial management network and supports data rates of 10/100 Mbps and 1 Gbps with autonegotiate. For more information about the CMM, see the following site:

[http://flexsystem.lenovofiles.com/help/topic/com.lenovo.acc.cmm.doc/cmm\\_product\\_page.html](http://flexsystem.lenovofiles.com/help/topic/com.lenovo.acc.cmm.doc/cmm_product_page.html)

**Note:** The second generation Lenovo Chassis Management Module (CMM2; 00FJ669) must be at firmware level 1.6.1 or above to support the ThinkSystem SN550. This applies to both CMMs that are installed in the chassis.



Function	Lenovo XClarity Administrator	Lenovo XClarity Integrator	Lenovo XClarity Energy Manager	Lenovo XClarity Provisioning Manager	Lenovo XClarity Essentials <sup>1</sup>	Lenovo XClarity Controller	Lenovo Capacity Planner	Lenovo Business Vantage
Multiple systems management	√	√	√		√			
Operating system deployment	√			√				
Firmware updates <sup>2</sup>	√	√		√ <sup>3</sup>	√	√		
System configuration	√	√		√	√	√		
Events / alerts	√	√	√			√		
Inventory / Log	√	√		√ <sup>4</sup>	√	√		
Power management		√ <sup>5</sup>	√					
Data center planning							√	
Security management								√ <sup>6</sup>

**Notes:**

1. Lenovo XClarity Essentials includes Lenovo XClarity Essentials OneCLI, Lenovo XClarity Essentials Bootable Media Creator, and Lenovo XClarity Essentials UpdateXpress.
2. Most options can be updated through the Lenovo tools. Some options, such as GPU firmware or Omni-Path firmware require the use of vendor tools.
3. Firmware updates are limited to Lenovo XClarity Provisioning Manager, Lenovo XClarity Controller firmware, and UEFI updates only. Firmware updates for optional devices, such as adapters, are not supported.
4. Limited inventory.
5. Power management function is supported by Lenovo XClarity Integrator for VMware vCenter.
6. Available only in the People's Republic of China.

**Lenovo XClarity Administrator**

Lenovo XClarity Administrator is a centralized, resource-management solution that simplifies infrastructure management, speeds responses, and enhances the availability of Lenovo server systems and solutions. It runs as a virtual appliance that automates discovery, inventory, tracking, monitoring, and provisioning for server, network, and storage hardware in a secure environment.

Lenovo XClarity Administrator provides a central interface to perform the following functions for all managed endpoints:

- **Manage and monitor hardware.** Lenovo XClarity Administrator provides agent-free hardware management. It can automatically discover manageable endpoints, including server, network, and storage hardware. Inventory data is collected for managed endpoints for an at-a-glance view of the managed hardware inventory and status.
- **Configuration management.** You can quickly provision and pre-provision all of your servers using a consistent configuration. Configuration settings (such as local storage, I/O adapters, boot settings, firmware, ports, and Lenovo XClarity Controller and UEFI settings) are saved as a server pattern that can be applied to one or more managed servers. When the server patterns are updated, the changes are automatically deployed to the applied servers.
- **Firmware compliance and updates.** Firmware management is simplified by assigning firmware-compliance policies to managed endpoints. When you create and assign a compliance policy to managed endpoints, Lenovo XClarity Administrator monitors changes to the inventory for those endpoints and flags any endpoints that are out of compliance.

When an endpoint is out of compliance, you can use Lenovo XClarity Administrator to apply and activate firmware updates for all devices in that endpoint from a repository of firmware updates that you manage.

- **Operating System deployment.** You can use Lenovo XClarity Administrator to manage a repository of operating-system images and to deploy operating-system images to up to 28 managed servers concurrently.
- **Service and support.** Lenovo XClarity Administrator can be set up to collect and send diagnostic files automatically to your preferred service provider when certain serviceable events occur in Lenovo XClarity Administrator and the managed endpoints. You can choose to send diagnostic files to Lenovo Support using Call Home or to another service provider using SFTP. You can also manually collect diagnostic files, open a problem record, and send diagnostic files to the Lenovo Support Center.

Lenovo XClarity Administrator can be integrated into external, higher-level management and automation platforms through open REST application programming interfaces (APIs). Using the REST APIs, Lenovo XClarity Administrator can easily integrate with your existing management infrastructure. In addition, you can automate tasks using the PowerShell toolkit or the Python toolkit.

To obtain the latest version of the Lenovo XClarity Administrator, see:

<https://datacentersupport.lenovo.com/us/en/documents/LNVO-LXCAUPD>

Documentation for Lenovo XClarity Administrator is available at:

[http://sysmgt.lenovofiles.com/help/topic/com.lenovo.lxca.doc/aug\\_product\\_page.html](http://sysmgt.lenovofiles.com/help/topic/com.lenovo.lxca.doc/aug_product_page.html)

### Lenovo XClarity Integrator

Lenovo also provides the following integrators that you can use to manage Lenovo servers from higher-level management tools:

- Lenovo XClarity Integrator for VMware vCenter
- Lenovo XClarity Integrator Microsoft System Center

For more information about Lenovo XClarity Integrator, see:

<http://www3.lenovo.com/us/en/data-center/software/systems-management/xclarity-integrators>

### Lenovo XClarity Energy Manager

Lenovo XClarity Energy Manager is a web-based power and temperature management solution designed for data center administrators. It monitors and manages the power consumption and temperature of servers, such as Converged, NeXtScale, System x, ThinkServer, and ThinkSystem servers. Lenovo XClarity Energy Manager models data center physical hierarchy and monitors power and temperature at the server/group level. By analyzing monitored power and temperature data, Lenovo XClarity Energy Manager greatly improves business continuity and energy efficiency.

With Lenovo XClarity Energy Manager, administrators can take control of power usage through improved data analysis and lower the TCO (total cost of ownership). The tool optimizes data center efficiency by allowing administrators to:

- Monitor energy consumption, estimate power need, and re-allocate power to servers as needed via IPMI or Redfish.
- Track platform power consumption, inlet temperature, CPU and memory power consumption.
- Visually check the layout of room, row and rack via 2D thermal map.
- Send notifications when certain events occur or thresholds are reached.
- Limit the consumed amount of energy of an endpoint by setting up policies.
- Optimize energy efficiency by monitoring real-time inlet temperatures, identifying low-usage servers based on out-of-band power data, measuring power rangers for different server models, and evaluating how servers accommodate new workloads based on the availability of resources.
- Reduce the power consumption to the minimum level to prolong service time during emergency power event (such as a data-center power failure).

For more information about downloading, installation, and usage, see:

<http://www3.lenovo.com/us/en/data-center/software/systems-management/xclarity-energy-manager/>

### Lenovo XClarity Provisioning Manager

Lenovo XClarity Provisioning Manager provides a graphic user interface for configuring the system. When you start a server and press F1, the Lenovo XClarity Provisioning Manager interface is displayed by default.

**Note:** The text-based interface to system configuration (the Setup Utility) is also available. From Lenovo XClarity Provisioning Manager, you can choose to restart the server and access the text-based interface. In addition, you can choose to make the text-based interface the default interface that is displayed when you press F1.

Lenovo XClarity Provisioning Manager provides a system summary of all installed devices and includes the following functions:

- **UEFI setup.** Use this function to configure UEFI system settings, such as processor configuration, start options, and user security. You can also view POST events and the System Event Log (SEL).
- **Platform update.** Use this function to update the firmware for Lenovo XClarity Controller, Lenovo XClarity Provisioning Manager, and operating system device drivers.
- **RAID setup.** Use this function to configure RAID for the server. It provides an easy-to-use graphical wizard that supports a unified process for performing RAID setup for a variety of RAID adapters. You can also perform advanced RAID configuration from the UEFI Setup.
- **OS installation.** Use this function to install an operating system for the server. You can install Microsoft Windows, Linux, and VMware ESXi.
- **Diagnostics.** Use this function to view the overall health of devices installed in the server and to perform diagnostics for hard disk drives and memory. You can also collect service data that can be saved to a USB device and sent to Lenovo Support.

**Note:** The service data collected by Lenovo XClarity Provisioning Manager does not include the operating system logs. To collect the operating system logs and the hardware service data, use Lenovo XClarity Essentials OneCLI.

Documentation for Lenovo XClarity Provisioning Manager is available at:

[http://sysmgt.lenovofiles.com/help/topic/LXPM/LXPM\\_introduction.html](http://sysmgt.lenovofiles.com/help/topic/LXPM/LXPM_introduction.html)

## Lenovo XClarity Essentials

Lenovo XClarity Essentials (LXCE) is a collection of server management utilities that provides a less complicated method to enable customers to manage Lenovo ThinkSystem, System x, and Thinkserver servers more efficiently and cost-effectively.

Lenovo XClarity Essentials includes the following utilities:

- Lenovo XClarity Essentials OneCLI is a collection of several command line applications, which can be used to:
  - Configure the server.
  - Collect service data for the server. If you run Lenovo XClarity Essentials OneCLI from the server operating system (in-band), you can collect operating system logs as well. You can also choose to view the service data that has been collected or to send the service data to Lenovo Support.
  - Update firmware and device drivers for the server. Lenovo XClarity Essentials OneCLI can help to download UpdateXpress System Packs (UXSPs) for your server and update all the firmware and device drivers payloads within the UXSP.
  - Perform miscellaneous functions, such as rebooting the server or rebooting the BMC.

To learn more about Lenovo XClarity Essentials OneCLI, see:

<https://datacentersupport.lenovo.com/us/en/documents/LNVO-CENTER>

Documentation for Lenovo XClarity Essentials OneCLI is available at:

[http://sysmgt.lenovofiles.com/help/topic/xclarity\\_essentials/overview.html](http://sysmgt.lenovofiles.com/help/topic/xclarity_essentials/overview.html)

- Lenovo XClarity Essentials Bootable Media Creator (BoMC) is a software application that applies UpdateXpress System Packs and individual updates to your system.

Using Lenovo XClarity Essentials Bootable Media Creator, you can:

- Update the server using an ISO image or CD.
- Update the server using a USB key.
- Update the server using the Preboot Execution Environment (PXE) interface.
- Update the server in unattendance mode.
- Update the server in Serial Over LAN (SOL) mode.

To learn more about Lenovo XClarity Essentials Bootable Media Creator, see:

<https://datacentersupport.lenovo.com/us/en/solutions/lnvo-bomc>

- Lenovo XClarity Essentials UpdateXpress is a software application that applies UpdateXpress System Packs and individual updates to your system.

Using Lenovo XClarity Essentials UpdateXpress, you can:

- Update the local server.
- Update a remote server.
- Create a repository of updates.

To learn more about Lenovo XClarity Essentials UpdateXpress, see:

<https://datacentersupport.lenovo.com/us/en/solutions/ht503692>

## Lenovo XClarity Controller

Lenovo XClarity Controller is the management processor for the server. It is the third generation of the Integrated Management Module (IMM) service processor that consolidates the service processor functionality, super I/O, video controller, and remote presence capabilities into a single chip on the server system board.

There are two ways to access the management processor:

- **Web-based interface.** To access the web-based interface, point your browser to the IP address for the management processor.
- **Command-line interface.** To access the CLI interface, use SSH or Telnet to log in to the management processor.

Whenever power is applied to a server, the management processor is available. From the management processor interface, you can perform the following functions:

- Monitor all hardware devices installed in the server.
- Power the server on and off.
- View the system event log and system audit log for the server.
- Use the Remote management function to log in to the server itself.

Documentation for Lenovo XClarity Controller is available at:

[http://sysmgt.lenovofiles.com/help/topic/com.lenovo.systems.management.xcc.doc/product\\_page.html](http://sysmgt.lenovofiles.com/help/topic/com.lenovo.systems.management.xcc.doc/product_page.html)

### **Lenovo Capacity Planner**

Lenovo Capacity Planner is a power consumption evaluation tool that enhances data center planning by enabling IT administrators and pre-sales to understand important parameters of different type of racks, servers, and other devices. Lenovo Capacity Planner can dynamically calculate the power consumption, current, British Thermal Unit (BTU), and volt-ampere (VA) rating at the rack level, and therefore improves the efficiency of large scale deployments.

Lenovo Capacity Planner provides the following functions:

- Power/thermal evaluation in different deployments, device copying, configuration saving, and reporting.
- Customizable server configuration, selectable workload, CPU turbo model, and worst case of fans for different evaluations in different user scenarios.
- Flex/Density servers, chassis and node level customizable configuration.
- Easy to download and run with popular web browsers, like Internet Explorer 11, Firefox, Chrome, and Edge.

**Note:** Users can also access the Lenovo website to run the tool online.

More information about Lenovo Capacity Planner is available at:

<http://datacentersupport.lenovo.com/us/en/products/solutions-and-software/software/lenovo-capacity-planner>

### **Lenovo Business Vantage**

Lenovo Business Vantage is a security software tool suite designed to work with the Trusted Cryptographic Module (TCM) adapter for enhanced security, to keep user data safe, and to erase confidential data completely from a hard disk drive.

Lenovo Business Vantage provides the following functions:

- **Data Safe.** Encrypt files to ensure data safety by using TCM chip , even when the disk is in “rest” status.
- **Sure Erase.** Erase confidential data from a hard disk. This tool follows the industry standard method to do the erasing and allows the user to select different erasing levels.
- **Smart USB Protection.** Prohibit unauthorized access to the USB port of devices.

- **USB Data Safe.** Encrypt data in USB Flash on a certain device and prohibit access of data on other devices.

**Note:** This tool is available in the People's Republic of China only.

More information about Lenovo Business Vantage is available at:

<http://www.lenovo.com>

## Chapter 2. Compute node components

Use the information in this section to learn about each of the components associated with your compute node.

### Power, controls, and indicators

Use this information to view power features, turn on and turn off the compute node, and view the functions of the controls and indicators.

### Compute node controls, connectors, and LEDs

Use this information for details about the controls, connectors, and LEDs.

The following illustration identifies the buttons, connectors, and LEDs on the control panel.

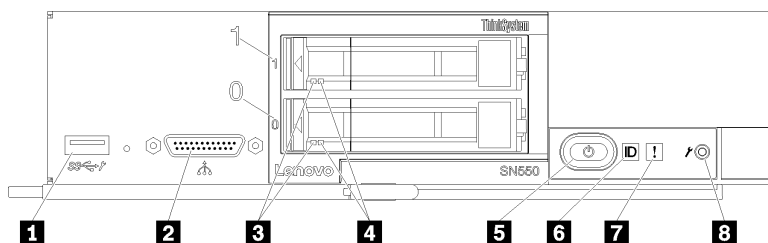

Figure 4. Compute node control panel buttons, connectors, and LEDs

Table 4. Compute node control panel buttons, connectors, and LEDs

<b>1</b> USB 3.0 connector	<b>5</b> Power button/LED (green)
<b>2</b> KVM connector	<b>6</b> Identification LED
<b>3</b> Drive activity LED (green)	<b>7</b> Fault LED (yellow)
<b>4</b> Drive status LED (yellow)	<b>8</b> USB management button

#### **1** USB 3.0 connector

Connect a USB device to this USB 3.0 connector.

**Note:** It is best practice to connect a USB device to the front of only one compute node at a time in each Lenovo Flex System chassis.

#### **2** KVM connector

Connect the console breakout cable to this connector (see “KVM cable” on page 19 for more information).

**Attention:** Use only the console breakout cable that comes with the chassis. Attempting to connect other console breakout cable types might damage the console breakout cable and the compute node.

**Note:** It is best practice to connect the console breakout cable to only one compute node at a time in each Lenovo Flex System chassis.

#### **3** Drive activity LED (green)

Green LEDs are on all hot swap drives. When this green LED is lit, it indicates that there is activity on the associated hard disk drive or solid-state drive.

- When this LED is flashing, it indicates that the drive is actively reading or writing data.
- For SAS and SATA drives, this LED is off when the drive is powered but not active.
- For NVMe (PCIe) SSDs, this LED is on solid when the drive is powered but not active.

**Note:** The drive activity LED might be in a different location on the front of the drive, depending on the drive type that is installed.

#### 4 Drive status LED (yellow)

The state of this yellow LED indicates an error condition or the RAID status of the associated hard disk drive or solid-state drive:

- When the yellow LED is lit continuously, it indicates that an error has occurred with the associated drive. The LED turns off only after the error is corrected. You can check the CMM event log to determine the source of the condition.
- When the yellow LED flashes slowly, it indicates that the associated drive is being rebuilt.
- When the yellow LED flashes rapidly, it indicates that the associated drive is being located.

**Note:** The hard disk drive status LED might be in a different location on the front of the hard disk drive, depending on the drive type that is installed.

#### 5 Power button/LED (green)

When the compute node is connected to power through the Lenovo Flex System chassis, press this button to turn on or turn off the compute node.

**Note:** The power button works only if local power control is enabled for the compute node. Local power control is enabled and disabled through the CMM **power** command and the CMM web interface.

- For more information about the CMM **power** command, see the *Flex System Chassis Management Module: Command-Line Interface Reference Guide* at [http://flexsystem.lenovofiles.com/help/topic/com.lenovo.acc.cmm.doc/cli\\_command\\_power.html](http://flexsystem.lenovofiles.com/help/topic/com.lenovo.acc.cmm.doc/cli_command_power.html).
- From the CMM web interface, select **Compute Nodes** from the **Chassis Management** menu. For more information, see the "Flex System Chassis Management Module: User's Guide" at [http://flexsystem.lenovofiles.com/help/topic/com.lenovo.acc.cmm.doc/cmm\\_user\\_guide.html](http://flexsystem.lenovofiles.com/help/topic/com.lenovo.acc.cmm.doc/cmm_user_guide.html). All fields and options are described in the CMM web interface online help.

After the compute node is removed from the chassis, press and hold this button to activate the system-board LEDs (light path diagnostics). See the *Lenovo ThinkSystem SN550 Type 7X16 Maintenance Manual* for more information.

This button is also the power LED. This green LED indicates the power status of the compute node:

- **Flashing rapidly (Four times per second):** The LED flashes rapidly for one of the following reasons:
  - The compute node has been installed in a powered chassis. When you install the compute node, the LED flashes rapidly while the XClarity Controller in the compute node is initializing and synchronizing with the Chassis Management Module. The time required for a compute node to initialize varies by system configuration.
  - Power permissions have not been assigned to the compute node through the Chassis Management Module.
  - The Lenovo Flex System chassis does not have enough power to turn on the compute node.
  - The XClarity Controller in the compute node is not communicating with the Chassis Management Module.

The power LED blink rate slows when the compute node is ready to be turned on.

- **Flashing slowly (One time per second):** The compute node is connected to power through the Lenovo Flex System chassis and is ready to be turned on.



- **Lit continuously:** The compute node is connected to power through the Lenovo Flex System chassis and is turned on.

When the compute node is on, pressing this button causes an orderly shutdown of the compute node so that it can be removed safely from the chassis. This includes shutting down the operating system (if possible) and removing power from the compute node.

**Attention:** If an operating system is running, you might have to press the button for approximately 4 seconds to initiate the shutdown. This forces the operating system to shut down immediately. Data loss is possible.

### 6 Identification LED (blue)

The system administrator can remotely light this blue LED to aid in visually locating the compute node. When this LED is lit, the identification LED on the Lenovo Flex System chassis is also lit. The identification LED can be lit and turned off through the CMM **led** command, the CMM web interface and the Lenovo XClarity Administrator application (if installed).

- For more information about the CMM **led** command, see the *Flex System Chassis Management Module: Command-Line Interface Reference Guide* at [http://flexsystem.lenovofiles.com/help/topic/com.lenovo.acc.cmm.doc/cli\\_command\\_led.html](http://flexsystem.lenovofiles.com/help/topic/com.lenovo.acc.cmm.doc/cli_command_led.html).
- From the CMM web interface, select **Compute Nodes** from the **Chassis Management** menu. For more information, see the "Flex System Chassis Management Module: User's Guide" at [http://flexsystem.lenovofiles.com/help/topic/com.lenovo.acc.cmm.doc/cmm\\_user\\_guide.html](http://flexsystem.lenovofiles.com/help/topic/com.lenovo.acc.cmm.doc/cmm_user_guide.html). All fields and options are described in the CMM web interface online help.
- For more information about the Lenovo XClarity Administrator application, see <https://support.lenovo.com/us/en/documents/LNVO-XCLARIT>.

### 7 Fault LED (yellow)

When this yellow LED is lit, it indicates that a system error has occurred in the compute node. In addition, the fault LED on the chassis system LED panel is lit. You can check the CMM event log and the light path diagnostics LEDs to determine the source of the condition. See "Light path diagnostics LEDs" on page 17 for more information about the LEDs on the compute node.

The fault LED turns off only after the error is corrected.

**Note:** When the fault LED turns off, you should also clear the XClarity Controller event log. Use the Setup utility to clear the XClarity Controller event log.

### 8 USB management button

Enables the USB port for system management.

**Note:** When enabling the USB port for system management, do not insert USB 3.0 devices.

## Light path diagnostics

Use this information as an overview of light path diagnostics.

Light path diagnostics is a system of LEDs above the control panel and on various internal components of the compute node. When an error occurs, LEDs can be lit throughout the compute node to help identify the source of the error.

### Light path diagnostics LEDs

Use this information to diagnose possible errors that are indicated by the light path diagnostics LEDs.

The following table describes the LEDs on the light path diagnostics panel and the light path diagnostics LEDs on the system board.

See the *Lenovo ThinkSystem SN550 Type 7X16 Maintenance Manual* for information about lighting the LEDs.

**Note:** Additional information about error conditions is in the CMM event log.

Table 5. Light path diagnostics LEDs

Light path diagnostics LED	Description
Light path diagnostics	The power source for the light path diagnostics LEDs is charged.
System board	The system board has failed.
NMI	The system board has failed.
CPU Mismatch	The processors are mismatched.
Temperature	The system temperature has exceeded a threshold level.
Memory	A memory error has occurred.
Storage BP 1	A hard disk drive backplane error has occurred.
M.2	A M.2 backplane error has occurred.

## System-board LEDs

Use this information to locate the system-board LEDs.

The following illustration shows the locations of the LEDs on the system board.

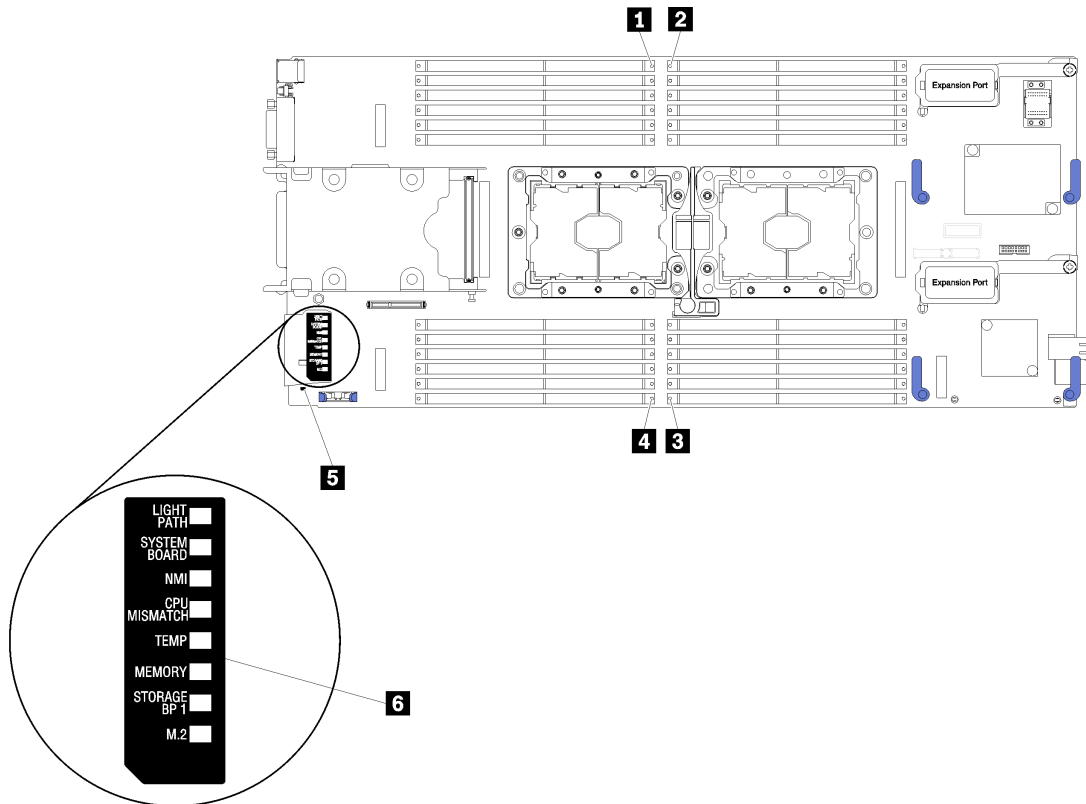

Figure 5. System-board LEDs

Table 6. System-board LEDs

<b>1</b> DIMM error 13–18 LEDs	<b>4</b> DIMM error 19–24 LEDs
<b>2</b> DIMM error 1–6 LEDs	<b>5</b> Battery error LEDs
<b>3</b> DIMM error 7–12 LEDs	<b>6</b> Light path diagnostics LEDs

See “Light path diagnostics LEDs” on page 17 for information about how to interpret the system-board LEDs.

## KVM cable

Use this information for details about the KVM cable.

Use the KVM cable to connect external I/O devices to the compute node. The KVM cable connects through the KVM connector (see “Compute node controls, connectors, and LEDs” on page 15). The console breakout cable has connectors for a display device (video), two USB 2.0 connectors for a USB keyboard and mouse, and a serial interface connector.

The following illustration identifies the connectors and components on the KVM cable.

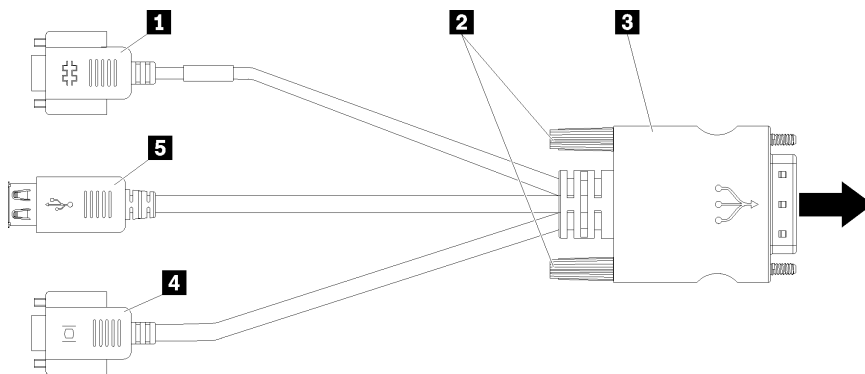

Figure 6. Connectors and components on the KVM cable

Table 7. Connectors and components on the KVM cable

<b>1</b> Serial connector	<b>4</b> Video connector (blue)
<b>2</b> Captive screws	<b>5</b> USB 2.0 ports (2)
<b>3</b> to KVM connector	

## System-board layout

Use this information to locate the connectors, LEDs, and switches on the system board.

### System-board connectors

Use this information to locate compute node system-board components and connectors for optional devices.

The following illustration shows the system-board components, including connectors for user-installable optional devices, in the compute node.

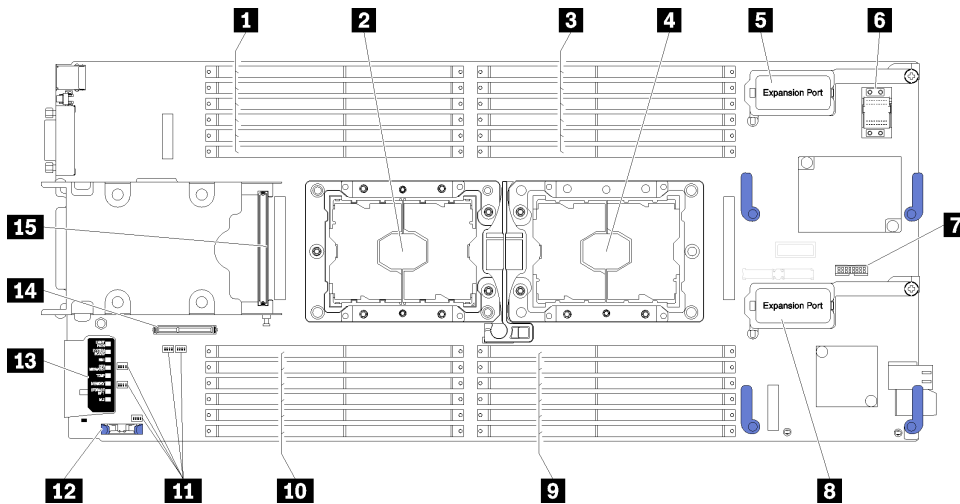

Figure 7. System-board connectors

Table 8. System-board connectors

<b>1</b> DIMM slots 13–18	<b>9</b> DIMM slots 7–12
<b>2</b> Processor socket 2	<b>10</b> DIMM slots 19–24
<b>3</b> DIMM slots 1–6	<b>11</b> Switch blocks
<b>4</b> Processor socket 1	<b>12</b> CMOS battery - CR2032
<b>5</b> I/O expansion 1 connector	<b>13</b> Light path diagnostics
<b>6</b> Fabric connector socket	<b>14</b> M.2 backplane connector
<b>7</b> Trusted Cryptographic Module (TCM) connector	<b>15</b> 2.5-inch drive backplane connector
<b>8</b> I/O expansion 2 connector	

## System-board switches

Use this information to locate the system-board switches.

The following illustration shows the location of the switch blocks on the system board.

### Important:

1. Before you change any switch settings or move any jumpers, turn off the compute node; then, disconnect all power cords and external cables. Review the information in [http://thinksystem.lenovofiles.com/help/topic/safety\\_documentation/pdf\\_files.html](http://thinksystem.lenovofiles.com/help/topic/safety_documentation/pdf_files.html), “Installation Guidelines” on page 26, “Handling static-sensitive devices” on page 28, and “Power on the compute node” on page 55.
2. Any system-board switch or jumper block that is not shown in the illustrations in this document are reserved.

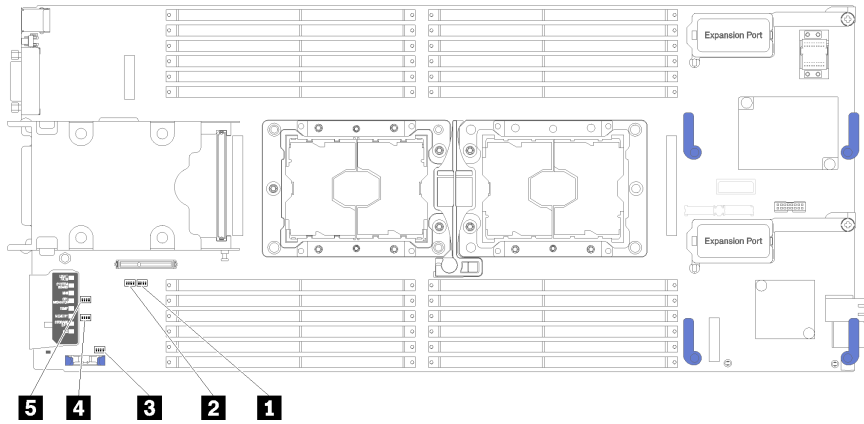

Figure 8. System board switches

Table 9. System board switches

<b>1</b> SW5 switch block	<b>4</b> SW3 switch block
<b>2</b> SW8 switch block	<b>5</b> SW2 switch block
<b>3</b> SW1 switch block	

**Note:** Any system-board switches or jumpers that are not described in this section are reserved.

Switch and jumper functions are as follows:

- All jumpers on the system board are reserved and should be removed.
- The following table describes the functions of the switches on switch block SW5.

Table 10. System-board switch block SW1

Switch number	Description	Definition
SW1-1	ME recovery	ME boots to recovery
SW1-2	ME firmware security override	For debug only.
SW1-3	Power permission	Changing this switch to the on position enables Power On
SW1-4	BMC reset	Changing this switch to the on position forces the compute node to reset the BMC.

- The following table describes the functions of the switches on switch block SW5.

Table 11. System-board switch block SW5

Switch number	Description	Definition
SW5-1	Password override	The default position is Off. Changing this switch to the On position overrides the power-on password.
SW5-2	Trusted Platform Module (TPM) physical presence	The default position is Off. Changing this switch to the On position indicates a physical presence to the TPM.

Table 11. System-board switch block SW5 (continued)

Switch number	Description	Definition
SW5-3	Real time clock (RTC) reset	The default position is Off. Changing this switch to the On position resets the RTC. A momentary toggle is all that is required. To avoid excessive CMOS battery drain, do not leave this switch in the On position.
SW5-4	Serial select	The default position is Off (send the serial input output (SIO) to the front serial port). Changing this switch to the On position sends the BMC to the serial port.

- The following table describes the functions of the switches on switch block SW8.

Table 12. System-board switch block SW8

Switch number	Description	Definition
SW8-1	Boot backup XClarity Controller	When the switch is in the default Off position, the compute node will boot by using the primary XClarity Controller firmware. When the switch is in the On position, the compute node will boot by using a backup of the XClarity Controller firmware.
SW8-2	Boot backup UEFI	The default position is Off. Changing this switch to the On position forces the compute node to boot from the backup UEFI image.
SW8-3	iBMC force update	The default position is Off. Changing this switch to the On position bypasses the operational firmware image and performs a BMC firmware update, if the normal firmware update procedure results in an inoperative BMC. <b>Note:</b> Use this switch only if the normal firmware update procedure fails and the operational firmware image is corrupted. Use of this switch disables normal baseboard management controller operation.
SW8-4	Wake on LAN (WOL) disable	Changing this switch to the On position disables WOL.

## Parts list

Use the parts list to identify each of the components that are available for your compute node.

For more information about ordering the parts shown in Figure 9 “Compute node components” on page 23:

<https://datacentersupport.lenovo.com/products/servers/thinksystem/sn550/7x16/parts>

**Note:** Depending on the model, your compute node might look slightly different from the illustration.

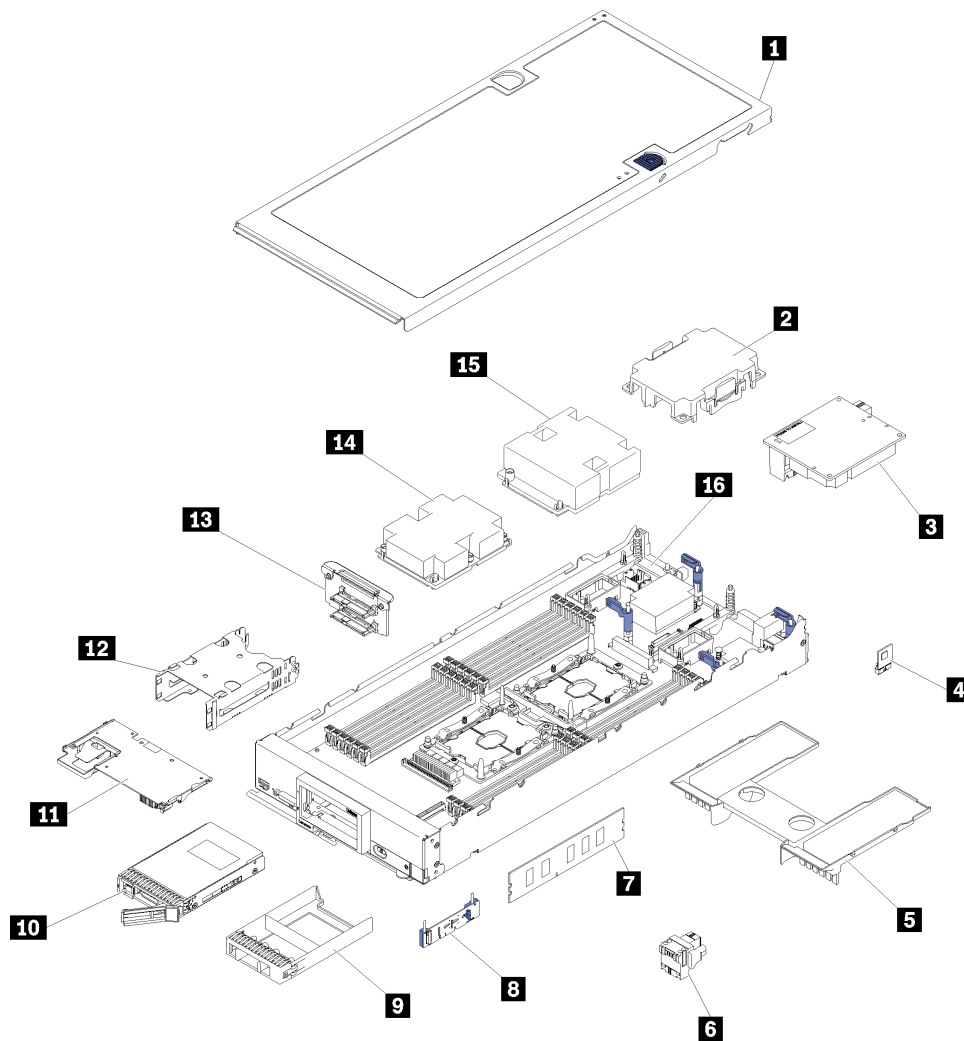

Figure 9. Compute node components

The parts listed in the following table are identified as one of the following:

- **Tier 1 customer replaceable unit (CRU):** Replacement of Tier 1 CRUs is your responsibility. If Lenovo installs a Tier 1 CRU at your request with no service agreement, you will be charged for the installation.
- **Tier 2 customer replaceable unit:** You may install a Tier 2 CRU yourself or request Lenovo to install it, at no additional charge, under the type of warranty service that is designated for your server.
- **Field replaceable unit (FRU):** FRUs must be installed only by trained service technicians.
- **Consumable and Structural parts:** Purchase and replacement of consumable and structural parts (components, such as a cover or bezel) is your responsibility. If Lenovo acquires or installs a structural component at your request, you will be charged for the service.

Table 13. Parts listing

Index	Description	Consumable and Structural part	Tier 1 CRU	Tier 2 CRU	FRU
For more information about ordering the parts shown in Figure 9 “Compute node components” on page 23: <a href="https://datacentersupport.lenovo.com/products/servers/thinksystem/sn550/7x16/parts">https://datacentersupport.lenovo.com/products/servers/thinksystem/sn550/7x16/parts</a>					
<b>1</b>	Compute node cover	√			
<b>2</b>	Processor heat sink filler	√			
<b>3</b>	I/O expansion adapter		√		
<b>4</b>	Trusted Cryptographic Module				√
<b>5</b>	Air baffle	√			
<b>6</b>	Fabric connector		√		
<b>7</b>	Memory module		√		
<b>8</b>	M.2 backplane		√		
<b>9</b>	Drive bay filler	√			
<b>10</b>	2.5-inch drive		√		
<b>11</b>	RAID adapter		√		
<b>12</b>	Storage cage	√			
<b>13</b>	2.5-inch drive backplane		√		
<b>14</b>	Processor 2, heat sink, and clip assembly				√
<b>15</b>	Processor 1, heat sink, and clip assembly				√
<b>16</b>	System board				√



---

## Chapter 3. Compute node hardware setup

To set up the compute node, install any options that have been purchased, cable the compute node, configure and update the firmware, and install the operating system.

---

### Compute node setup checklist

Use the compute node setup checklist to ensure that you have performed all tasks that are required to set up your compute node.

The compute node setup procedure varies depending on the configuration of the compute node when it was delivered. In some cases, the compute node is fully configured and you just need to connect the compute node to the network and an ac power source, and then you can power on the compute node. In other cases, the compute node needs to have hardware options installed, requires hardware and firmware configuration, and requires an operating system to be installed.

The following steps describe the general procedure for setting up a compute node:

1. Unpack the compute node package. See “Compute node package contents” on page 3.
2. Set up the compute node hardware.
  - a. Install the required compute node components. See the related topics in “Install compute node hardware options” on page 28.
  - b. Install the compute node into the chassis.
  - c. Make sure the chassis is connected to power.
  - d. Connect the management controller to the network.
  - e. Power on the compute node.

**Note:** You can access the management processor interface to configure the system without powering on the compute node. Whenever the compute node is connected to power, the management processor interface is available. For details about accessing the management compute node processor, see: [http://sysmgt.lenovofiles.com/help/topic/com.lenovo.systems.management.xcc.doc/dw1lm\\_c\\_chapter2\\_openingandusing.html](http://sysmgt.lenovofiles.com/help/topic/com.lenovo.systems.management.xcc.doc/dw1lm_c_chapter2_openingandusing.html)
  - f. Validate that the compute node hardware was set up successfully. See Validate compute node setup.
3. Configure the system.
  - a. Connect the Lenovo XClarity Controller to the management network. See Set the network connection for the Lenovo XClarity Controller.
  - b. Update the firmware for the compute node, if necessary. See “Update the firmware” on page 60.
  - c. Configure the firmware for the compute node. See “Configure the firmware” on page 62.

The following information is available for RAID configuration:

    - <https://lenovopress.com/lp0578-lenovo-raid-introduction>
    - <https://lenovopress.com/lp0579-lenovo-raid-management-tools-and-resources>
  - d. Install the operating system. See “Install the operating system” on page 67.
  - e. Back up the compute node configuration. See “Back up the compute node configuration” on page 68.
  - f. Install the applications and programs for which the compute node is intended to be used.

## Notes:

- The first generation Chassis Management Module (CMM1; 68Y7030) is not supported by the ThinkSystem SN550 compute node.
- The second generation Chassis Management Module (CMM2; 00FJ669) must be at firmware level 1.6.1 or above to support the ThinkSystem SN550 compute node. This applies to both CMMs that are installed in the chassis.

---

## Installation Guidelines

Use the installation guidelines to install components in your server.

Before installing optional devices, read the following notices carefully:

**Attention:** Prevent exposure to static electricity, which might lead to system halt and loss of data, by keeping static-sensitive components in their static-protective packages until installation, and handling these devices with an electrostatic-discharge wrist strap or other grounding system.

- Read the safety information and guidelines to ensure that you work safely.
  - A complete list of safety information for all products is available at:  
[http://thinksystem.lenovofiles.com/help/topic/safety\\_documentation/pdf\\_files.html](http://thinksystem.lenovofiles.com/help/topic/safety_documentation/pdf_files.html)
  - The following guidelines are available as well: “Handling static-sensitive devices” on page 28 and “Working inside the server with the power on” on page 27.
- Make sure the components you are installing are supported by the server. For a list of supported optional components for the server, see <http://www.lenovo.com/serverproven/>.
- When you install a new server, download and apply the latest firmware. This will help ensure that any known issues are addressed, and that your server is ready to work with optimal performance. Go to ThinkSystem SN550 Drivers and Software to download firmware updates for your server.

**Important:** Some cluster solutions require specific code levels or coordinated code updates. If the component is part of a cluster solution, verify that the latest level of code is supported for the cluster solution before you update the code.

- Before you remove a compute node from the Flex System chassis, you must shut down the operating system and turn off the compute node. You do not have to shut down the chassis itself.
- It is good practice to make sure that the server is working correctly before you install an optional component.
- Keep the working area clean, and place removed components on a flat and smooth surface that does not shake or tilt.
- Do not attempt to lift an object that might be too heavy for you. If you have to lift a heavy object, read the following precautions carefully:
  - Make sure that you can stand steadily without slipping.
  - Distribute the weight of the object equally between your feet.
  - Use a slow lifting force. Never move suddenly or twist when you lift a heavy object.
  - To avoid straining the muscles in your back, lift by standing or by pushing up with your leg muscles.
- Back up all important data before you make changes related to the disk drives.
- Have a small flat-blade screwdriver, a small Phillips screwdriver, and a T8 torx screwdriver available.
- To view the error LEDs on the system board and internal components, leave the power on.
- You do not have to turn off the server to remove or install hot-swap power supplies, hot-swap fans, or hot-plug USB devices. However, you must turn off the server before you perform any steps that involve

removing or installing adapter cables, and you must disconnect the power source from the server before you perform any steps that involve removing or installing a riser card.

- Blue on a component indicates touch points, where you can grip to remove a component from or install it in the server, open or close a latch, and so on.
- The Red strip on the drives, adjacent to the release latch, indicates that the drive can be hot-swapped if the server and operating system support hot-swap capability. This means that you can remove or install the drive while the server is still running.

**Note:** See the system specific instructions for removing or installing a hot-swap drive for any additional procedures that you might need to perform before you remove or install the drive.

- After finishing working on the server, make sure you reinstall all safety shields, guards, labels, and ground wires.

## System reliability guidelines

Review the system reliability guidelines to ensure proper system cooling and reliability.

Make sure the following requirements are met:

- To ensure proper cooling, the Flex System chassis is not operated without a compute node or node bay filler in each node bay.
- When the server comes with redundant power, a power supply must be installed in each power-supply bay.
- Adequate space around the server must be spared to allow server cooling system to work properly. Leave approximately 50 mm (2.0 in.) of open space around the front and rear of the server. Do not place any object in front of the fans.
- For proper cooling and airflow, refit the server cover before you turn the power on. Do not operate the server for more than 30 minutes with the server cover removed, for it might damage server components.
- Cabling instructions that come with optional components must be followed.
- A failed fan must be replaced within 48 hours since malfunction.
- A removed hot-swap fan must be replaced within 30 seconds after removal.
- A removed hot-swap drive must be replaced within two minutes after removal.
- A removed hot-swap power supply must be replaced within two minutes after removal.
- Every air baffle that comes with the server must be installed when the server starts (some servers might come with more than one air baffle). Operating the server with a missing air baffle might damage the processor.
- All processor sockets must contain either a socket cover or a processor with heat sink.
- When more than one processor is installed, fan population rules for each server must be strictly followed.

## Working inside the server with the power on

Guidelines to work inside the server with the power on.

**Attention:** The server might stop and loss of data might occur when internal server components are exposed to static electricity. To avoid this potential problem, always use an electrostatic-discharge wrist strap or other grounding systems when working inside the server with the power on.

- Avoid loose-fitting clothing, particularly around your forearms. Button or roll up long sleeves before working inside the server.
- Prevent your necktie, scarf, badge rope, or long hair from dangling into the server.
- Remove jewelry, such as bracelets, necklaces, rings, cuff links, and wrist watches.

- Remove items from your shirt pocket, such as pens and pencils, in case they fall into the server as you lean over it.
- Avoid dropping any metallic objects, such as paper clips, hairpins, and screws, into the server.

## Handling static-sensitive devices

Use this information to handle static-sensitive devices.

**Attention:** Prevent exposure to static electricity, which might lead to system halt and loss of data, by keeping static-sensitive components in their static-protective packages until installation, and handling these devices with an electrostatic-discharge wrist strap or other grounding system.

- Limit your movement to prevent building up static electricity around you.
- Take additional care when handling devices during cold weather, for heating would reduce indoor humidity and increase static electricity.
- Always use an electrostatic-discharge wrist strap or other grounding system, particularly when working inside the server with the power on.
- While the device is still in its static-protective package, touch it to an unpainted metal surface on the outside of the server for at least two seconds. This drains static electricity from the package and from your body.
- Remove the device from the package and install it directly into the server without putting it down. If it is necessary to put the device down, put it back into the static-protective package. Never place the device on the server or on any metal surface.
- When handling a device, carefully hold it by the edges or the frame.
- Do not touch solder joints, pins, or exposed circuitry.
- Keep the device from others' reach to prevent possible damages.

---

## Install compute node hardware options

This section includes instructions for performing initial installation of optional hardware. Each component installation procedure references any tasks that need to be performed to gain access to the component being replaced.

Installation procedures are presented in the optimum sequence to minimize work.

**Attention:** To ensure the components you install work correctly without problems, read the following precautions carefully.

- Make sure the components you are installing are supported by the server. For a list of supported optional components for the server, see <http://www.lenovo.com/serverproven/>.
- Always download and apply the latest firmware. This will help ensure that any known issues are addressed, and that your server is ready to work with optimal performance. Go to ThinkSystem SN550 Drivers and Software to download firmware updates for your server.
- It is good practice to make sure that the server is working correctly before you install an optional component.
- Follow the installation procedures in this section and use appropriate tools. Incorrectly installed components can cause system failure from damaged pins, damaged connectors, loose cabling, or loose components.

## Remove the top cover

Remove the top cover by pulling up the cover-release latch and sliding the cover toward the rear of the server.

1. Read the safety information and guidelines to ensure that you work safely.

- The safety information is available at:  
[http://thinksystem.lenovofiles.com/help/topic/safety\\_documentation/pdf\\_files.html](http://thinksystem.lenovofiles.com/help/topic/safety_documentation/pdf_files.html)
- These guidelines are available as well: “Working inside the server with the power on” on page 27, and “Handling static-sensitive devices” on page 28.

### **S012**



**CAUTION:**  
Hot surface nearby.

### **S021**



**CAUTION:**  
Hazardous energy is present when the blade is connected to the power source. Always replace the blade cover before installing the blade.

2. Carefully lay the compute node on a flat, static-protective surface, orienting the compute node with the bezel pointing toward you.

To remove the compute node cover, complete the following steps:

**Watch the procedure.** A video of the installation process is available:

- Youtube: [https://www.youtube.com/playlist?list=PLYV5R7hVcs-B4\\_LYuT9X1MRWBU6UzX9gO](https://www.youtube.com/playlist?list=PLYV5R7hVcs-B4_LYuT9X1MRWBU6UzX9gO)
- Youku: [http://list.youku.com/albumlist/show/id\\_50481482](http://list.youku.com/albumlist/show/id_50481482)

Step 1. Press on the release button and the push point at the same time and slide the cover toward the rear of the compute node.

Step 2. Lift the cover away from the compute node.

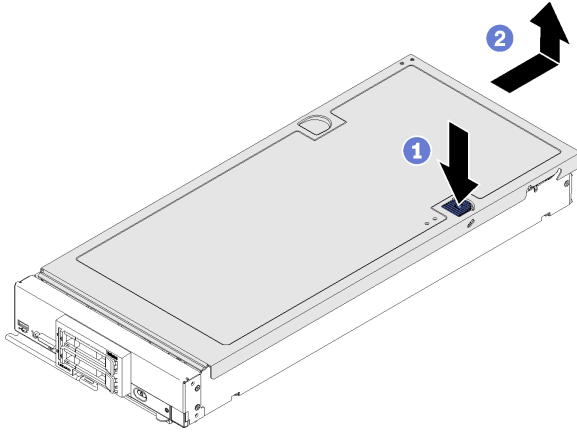

Figure 10. Compute node cover removal

Step 3. Lay the cover flat or store it for future use.

## Remove the air baffle

If you intend to install DIMMs in the compute node, you must first remove the air baffle from the compute node. Remove the air baffle by placing your fingers under the air baffle and lifting it out of the compute node.

Before removing the air baffle:

1. Read the safety information and guidelines to ensure that you work safely.
  - The safety information is available at:  
[http://thinksystem.lenovofiles.com/help/topic/safety\\_documentation/pdf\\_files.html](http://thinksystem.lenovofiles.com/help/topic/safety_documentation/pdf_files.html)
  - These guidelines are available as well: “Working inside the server with the power on” on page 27, and “Handling static-sensitive devices” on page 28.

### **S012**



**CAUTION:**  
**Hot surface nearby.**

2. Carefully lay the compute node on a flat, static-protective surface, orienting the compute node with the bezel pointing toward you.
3. Remove the compute node cover (see “Remove the top cover” on page 29).

To remove the air baffle, complete the following steps:

**Watch the procedure.** A video of the installation process is available:

- Youtube: [https://www.youtube.com/playlist?list=PLYV5R7hVcs-B4\\_LYuT9X1MRWBU6UzX9gO](https://www.youtube.com/playlist?list=PLYV5R7hVcs-B4_LYuT9X1MRWBU6UzX9gO)
- Youku: [http://list.youku.com/albumlist/show/id\\_50481482](http://list.youku.com/albumlist/show/id_50481482)

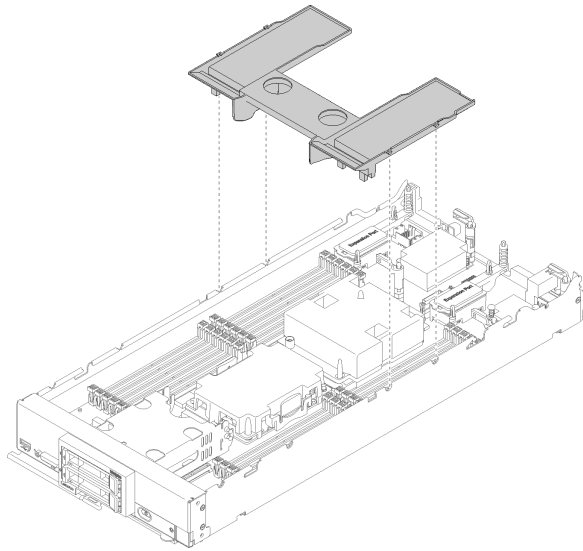

Figure 11. Air baffle removal

Step 1. Lift the air baffle up and set it aside.

**Attention:** For proper cooling and airflow, reinstall the air baffle before you turn on the compute node. Operating the compute node with the air baffle removed might damage compute node components.

After removing the air baffle, begin installing any options that you have purchased.

## Remove the 2.5-inch drive backplane

Use this information to remove the 2.5-inch drive backplane.

Before you remove the 2.5-inch drive backplane, complete the following steps:

1. Read the safety information and guidelines to ensure that you work safely.
  - The safety information is available at:  
[http://thinksystem.lenovofiles.com/help/topic/safety\\_documentation/pdf\\_files.html](http://thinksystem.lenovofiles.com/help/topic/safety_documentation/pdf_files.html)
  - These guidelines are available as well: “Working inside the server with the power on” on page 27, and “Handling static-sensitive devices” on page 28.
2. Carefully lay the compute node on a flat, static-protective surface, orienting the compute node with the bezel pointing toward you.
3. Remove the compute node cover (see “Remove the top cover” on page 29).

### Notes:

- Several different types of 2.5-inch drive backplanes can be installed in the compute node. For example, some 2.5-inch drive backplanes come with a lever, while others don’t (refer to the illustrations below). All are removed and installed in a similar manner.
- See the documentation that comes with an optional drive backplane for device-specific information and information about removing other components that might be included as part of the option.
- If necessary, remove the RAID adapter to more easily access the drive backplane. (see “Remove the RAID adapter” on page 32).

To remove the 2.5-inch drive backplane, complete the following steps:

**Watch the procedure.** A video of the installation process is available:

- Youtube: [https://www.youtube.com/playlist?list=PLYV5R7hVcs-B4\\_LYuT9X1MRWBU6UzX9gO](https://www.youtube.com/playlist?list=PLYV5R7hVcs-B4_LYuT9X1MRWBU6UzX9gO)
- Youku: [http://list.youku.com/albumlist/show/id\\_50481482](http://list.youku.com/albumlist/show/id_50481482)

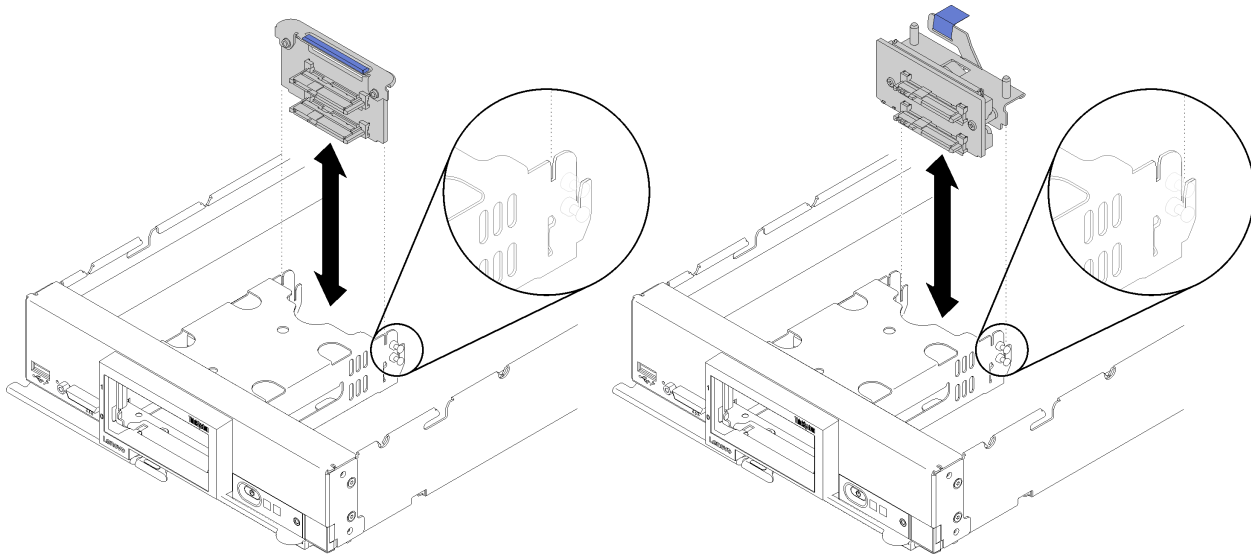

Figure 12. 2.5-inch drive backplane removal

- Step 1. Remove any drive bay fillers; then, pull the drives out slightly from the bays to disengage them from the backplane.
- Step 2. Lift out the 2.5-inch drive backplane.

If you are instructed to return the component or optional device, follow all packaging instructions, and use any packaging materials for shipping that are supplied to you.

## Remove the RAID adapter

Use this information to remove the RAID adapter.

Before you remove the RAID adapter, complete the following steps:

1. Read the safety information and guidelines to ensure that you work safely.
  - The safety information is available at:  
[http://thinksystem.lenovofiles.com/help/topic/safety\\_documentation/pdf\\_files.html](http://thinksystem.lenovofiles.com/help/topic/safety_documentation/pdf_files.html)
  - These guidelines are available as well: “Working inside the server with the power on” on page 27, and “Handling static-sensitive devices” on page 28.
2. Carefully lay the compute node on a flat, static-protective surface, orienting the compute node with the bezel pointing toward you.
3. Remove the compute node cover (see “Remove the top cover” on page 29).

The RAID adapter uses a specific drive backplane.

- If you need to remove the RAID adapter to access components on the system board (for example DIMM sockets 13-24), there is no need to remove the backplane.
- If you are removing only the RAID adapter to replace it, there is no need to remove the backplane.

To remove the RAID adapter, complete the following steps:



**Watch the procedure.** A video of the installation process is available:

- Youtube: [https://www.youtube.com/playlist?list=PLYV5R7hVcs-B4\\_LYuT9X1MRWBU6UzX9gO](https://www.youtube.com/playlist?list=PLYV5R7hVcs-B4_LYuT9X1MRWBU6UzX9gO)
- Youku: [http://list.youku.com/albumlist/show/id\\_50481482](http://list.youku.com/albumlist/show/id_50481482)

Step 1. Locate the RAID adapter installed in the compute node.

Step 2. Remove the RAID adapter.

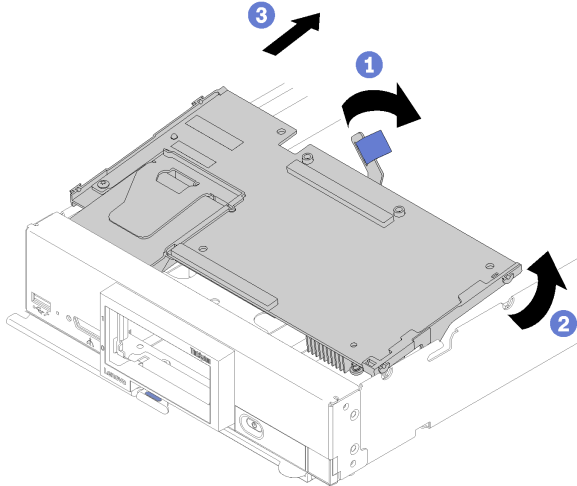

Figure 13. RAID adapter removal

- a. Rotate the lever on the hard disk drive backplane to disengage the RAID adapter from the backplane connector.
- b. Lift the RAID adapter and remove it from the compute node.

If you are instructed to return the component or optional device, follow all packaging instructions, and use any packaging materials for shipping that are supplied to you.

## Install a 2.5-inch drive backplane

Use this information to install a 2.5-inch drive backplane option.

Before you install a 2.5-inch drive backplane, complete the following steps:

1. Read the safety information and guidelines to ensure that you work safely.
  - The safety information is available at:  
[http://thinksystem.lenovofiles.com/help/topic/safety\\_documentation/pdf\\_files.html](http://thinksystem.lenovofiles.com/help/topic/safety_documentation/pdf_files.html)
  - These guidelines are available as well: “Working inside the server with the power on” on page 27, and “Handling static-sensitive devices” on page 28.
2. Carefully lay the compute node on a flat, static-protective surface, orienting the compute node with the bezel pointing toward you.
3. Remove the compute node cover (see “Remove the top cover” on page 29).

### Notes:

- Several different types of 2.5-inch drive backplanes can be installed in the compute node. For example, some 2.5-inch drive backplanes come with a lever, while others don’t (refer to the illustrations below). All are removed and installed in a similar manner.
- See the documentation that comes with an optional 2.5-inch drive backplane for device-specific information and information about installing other components that might be included as part of the option

or about other components or modules that must be installed to use the option. For example, some optional 2.5-inch drive backplanes might require installation of a second processor.

To install a 2.5-inch drive backplane, complete the following steps:

**Watch the procedure.** A video of the installation process is available:

- Youtube: [https://www.youtube.com/playlist?list=PLYV5R7hVcs-B4\\_LYuT9X1MRWBU6UzX9gO](https://www.youtube.com/playlist?list=PLYV5R7hVcs-B4_LYuT9X1MRWBU6UzX9gO)
- Youku: [http://list.youku.com/albumlist/show/id\\_50481482](http://list.youku.com/albumlist/show/id_50481482)

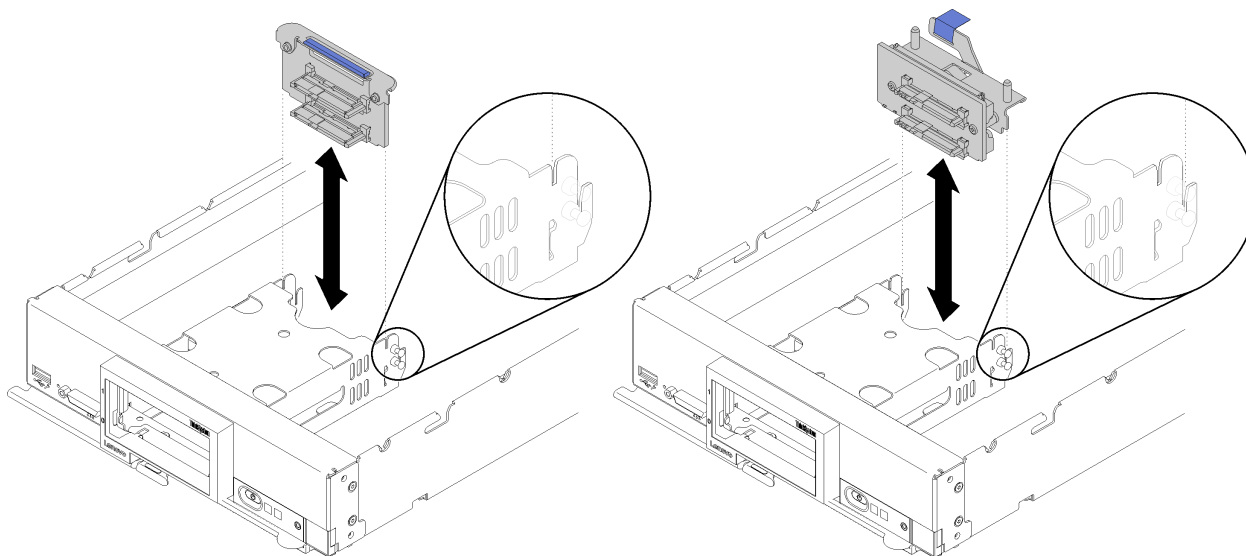

Figure 14. 2.5-inch drive backplane installation

Step 1. Align the backplane with the storage cage and the connector on the system board and press the backplane into position until it is fully seated in the connector.

**Note:** All 2.5-inch drive backplanes use the same connector on the system board; however, there are two alignment slots in the storage cage to accommodate different backplane types. Make sure that you align the backplane and system board connectors when inserting the backplane in the storage cage.

After you install the 2.5-inch drive backplane, complete the following steps:

- If the RAID adapter was removed, install it now. (see “Install a RAID adapter” on page 49).
- Install any removed storage drives and drive bay fillers (see “Install a 2.5-inch hot-swap drive” on page 34).

**Note:** Install storage drives in the same bay locations as from which they were removed.

- Install the compute node cover (see “Install the compute node cover” on page 52 ).
- Install the compute node into the chassis (see “Install the compute node in the chassis” on page 54 ).

## Install a 2.5-inch hot-swap drive

Use this information to install a 2.5-inch hot-swap drive option.

Before you install a 2.5-inch hot-swap drive, complete the following steps:

1. Read the safety information and guidelines to ensure that you work safely.
  - The safety information is available at:  
[http://thinksystem.lenovofiles.com/help/topic/safety\\_documentation/pdf\\_files.html](http://thinksystem.lenovofiles.com/help/topic/safety_documentation/pdf_files.html)

- These guidelines are available as well: “Working inside the server with the power on” on page 27, and “Handling static-sensitive devices” on page 28.
2. Carefully lay the compute node on a flat, static-protective surface, orienting the compute node with the bezel pointing toward you.

The compute node has two 2.5-inch drive bays for installing hot-swap drives. One drive might already be installed in the compute node. If the compute node is equipped with one drive, you can install an additional drive. RAID level-0 (striping) can be configured on a compute node with a single drive installed. A minimum of two disk drives of the same interface type must be installed to implement and manage RAID level-1 (mirroring) arrays. See the *Lenovo ThinkSystem SN550 Type 7X16 Setup Guide* for more information.

To install a 2.5-inch hot-swap drive, complete the following steps:

**Watch the procedure.** A video of the installation process is available:

- Youtube: [https://www.youtube.com/playlist?list=PLYV5R7hVcs-B4\\_LYuT9X1MRWBU6UzX9gO](https://www.youtube.com/playlist?list=PLYV5R7hVcs-B4_LYuT9X1MRWBU6UzX9gO)
- Youku: [http://list.youku.com/albumlist/show/id\\_50481482](http://list.youku.com/albumlist/show/id_50481482)

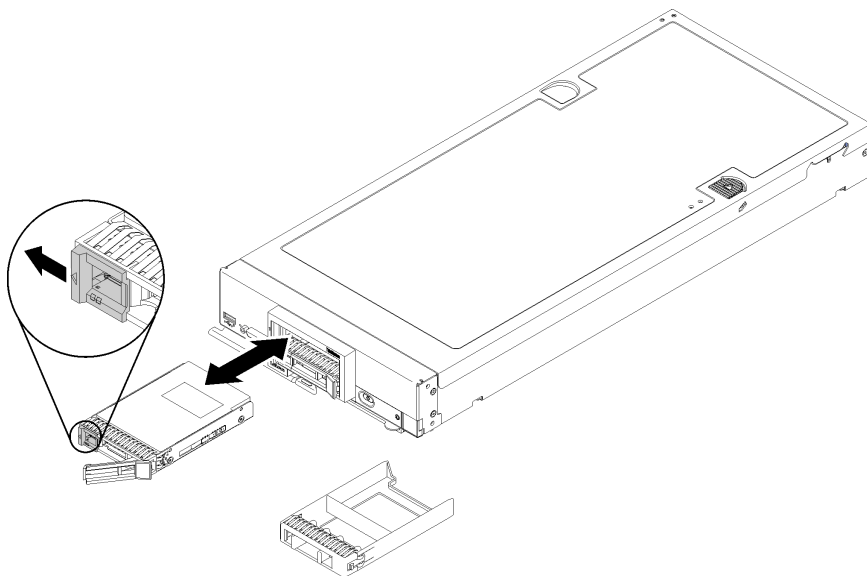

Figure 15. 2.5-inch hot-swap drive installation

- Step 1. Identify the drive bay in which you plan to install the hot-swap drive.
- Step 2. If a drive bay filler is installed, remove it from the compute node by pulling the release lever and sliding the filler away from the compute node.
- Step 3. Touch the static-protective package that contains the hot-swap drive to any *unpainted* metal surface on the Lenovo Flex System chassis or any *unpainted* metal surface on any other grounded rack component; then, remove the drive from the package.
- Step 4. Open the release lever on the hot-swap drive and slide the drive into the bay until the lever catches on the bezel, then rotate the handle to fully seat the drive.
- Step 5. Lock the drive into place by closing the release lever.
- Step 6. Check the drive status LEDs to make sure that the drive is operating correctly.

## Install a DIMM

Use this information to install a DIMM option.

Before installing a DIMM, make sure that you understand the required installation order, depending on whether you are implementing memory mirroring, memory rank sparing, or independent memory mode. See “Installation order” on page 38 for the required installation order.

If you are installing an optional processor, install it before installing DIMMs. See “Install a processor-heat-sink module” on page 47

Before you install a DIMM, complete the following steps:

1. Read the safety information and guidelines to ensure that you work safely.
  - The safety information is available at:  
[http://thinksystem.lenovofiles.com/help/topic/safety\\_documentation/pdf\\_files.html](http://thinksystem.lenovofiles.com/help/topic/safety_documentation/pdf_files.html)
  - These guidelines are available as well: “Working inside the server with the power on” on page 27, and “Handling static-sensitive devices” on page 28.
2. Carefully lay the compute node on a flat, static-protective surface, orienting the compute node with the bezel pointing toward you.
3. Remove the compute node cover (see “Remove the top cover” on page 29).

To install a DIMM, complete the following steps:

**Watch the procedure.** A video of the installation process is available:

- Youtube: [https://www.youtube.com/playlist?list=PLYV5R7hVcs-B4\\_LYuT9X1MRWBU6UzX9gO](https://www.youtube.com/playlist?list=PLYV5R7hVcs-B4_LYuT9X1MRWBU6UzX9gO)
- Youku: [http://list.youku.com/albumlist/show/id\\_50481482](http://list.youku.com/albumlist/show/id_50481482)

**Attention:** Memory modules are sensitive to static discharge and require special handling. In addition to the standard guidelines for Handling static-sensitive devices:

- Always wear an electrostatic-discharge strap when removing or installing memory modules. Electrostatic-discharge gloves can also be used.
- Never hold two or more memory modules together so that they touch. Do not stack memory modules directly on top of each other during storage.
- Never touch the gold memory module connector contacts or allow these contacts to touch the outside of the memory-module connector housing.
- Handle memory modules with care: never bend, twist, or drop a memory module.

**Note:** Remove or install DIMMs for one processor at a time.

Step 1. Locate the DIMM connectors. Determine which DIMM connector you want to install the DIMM.

Step 2. Touch the static-protective package that contains the DIMM to any *unpainted* metal surface on the Lenovo Flex System chassis or any *unpainted* metal surface on any other grounded rack component in the rack in which you are installing the DIMM for at least 2 seconds; then, remove the DIMM from its package.

Step 3. Make sure that both retaining clips on the DIMM connector are in the open position.

**Attention:**

- DIMMs are static-sensitive devices. The package must be grounded before it is opened.
- To avoid breaking the retaining clips or damaging the DIMM connector, handle the clips gently.

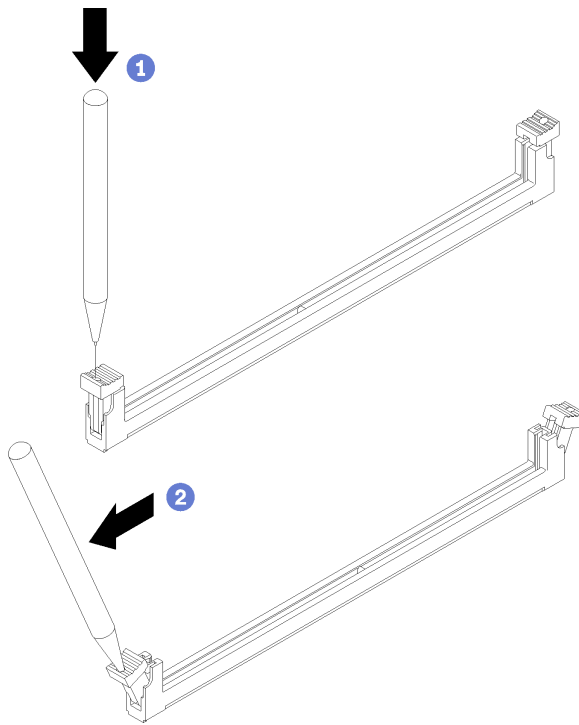

Figure 16. Opening retaining clip

**Notes:**

- If necessary, due to space constraints, you can use a pointed tool to open the retaining clips. Place the tip of the tool in the recess on the top of the retaining clip; then, carefully rotate the retaining clip away from the DIMM connector.
- The retaining clips for adjacent DIMM connectors of processor one and processor two can not be open at the same time. Remove or install the DIMMs for each processor one at a time.

Step 4. Turn the DIMM so that the DIMM keys align correctly with the DIMM connector on the system board.

Step 5. Press the DIMM into the DIMM connector. The retaining clips lock the DIMM into the connector.

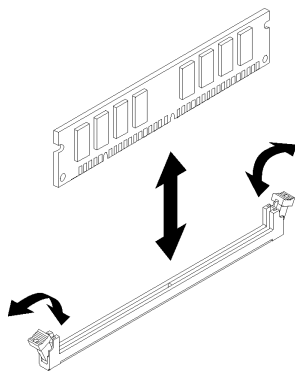

Figure 17. DIMM installation

Step 6. Make sure that the small tabs on the retaining clips engage the notches on the DIMM. If there is a gap between the DIMM and the retaining clips, the DIMM has not been correctly installed. Press

the DIMM firmly into the connector, and then press the retaining clips toward the DIMM until the tabs are fully seated.

**Note:** Retaining clips on the DIMM connectors must be in the closed position to install the air baffle.

After you install the memory module, complete the following steps:

- Install the air baffle (see “Install the air baffle” on page 52).

**Attention:** To maintain proper system cooling, do not operate the compute node without an air baffle installed over the memory module connectors.

- Install the compute node cover (see “Install the compute node cover” on page 52 ).
- Install the compute node into the chassis (see “Install the compute node in the chassis” on page 54 ).

## Installation order

DIMMs must be installed in a specific order based on the memory configuration that you implement on your compute node.

The following memory configurations are available:

### Memory mirroring population sequence

For information about memory mirroring, see “Memory mirroring” on page 65.

### Memory rank sparing population sequence

For information about memory rank sparing, see “Memory rank sparing” on page 66.

### Independent memory mode population sequence

For information about independent memory mode, see “Independent memory mode” on page 64.

## Install the flash power module

Use this information to install the flash power module.

Before you install the flash power module, complete the following steps:

1. Read the safety information and guidelines to ensure that you work safely.
  - The safety information is available at:  
[http://thinksystem.lenovofiles.com/help/topic/safety\\_documentation/pdf\\_files.html](http://thinksystem.lenovofiles.com/help/topic/safety_documentation/pdf_files.html)
  - These guidelines are available as well: “Working inside the server with the power on” on page 27, and “Handling static-sensitive devices” on page 28.
2. Carefully lay the compute node on a flat, static-protective surface, orienting the compute node with the bezel pointing toward you.

**Note:** This section only applies to RAID adapters that come with a flash power module.

To install the flash power module, complete the following steps:

**Watch the procedure.** A video of the installation process is available:

- Youtube: [https://www.youtube.com/playlist?list=PLYV5R7hVcs-B4\\_LYuT9X1MRWBU6UzX9gO](https://www.youtube.com/playlist?list=PLYV5R7hVcs-B4_LYuT9X1MRWBU6UzX9gO)
- Youku: [http://list.youku.com/albumlist/show/id\\_50481482](http://list.youku.com/albumlist/show/id_50481482)

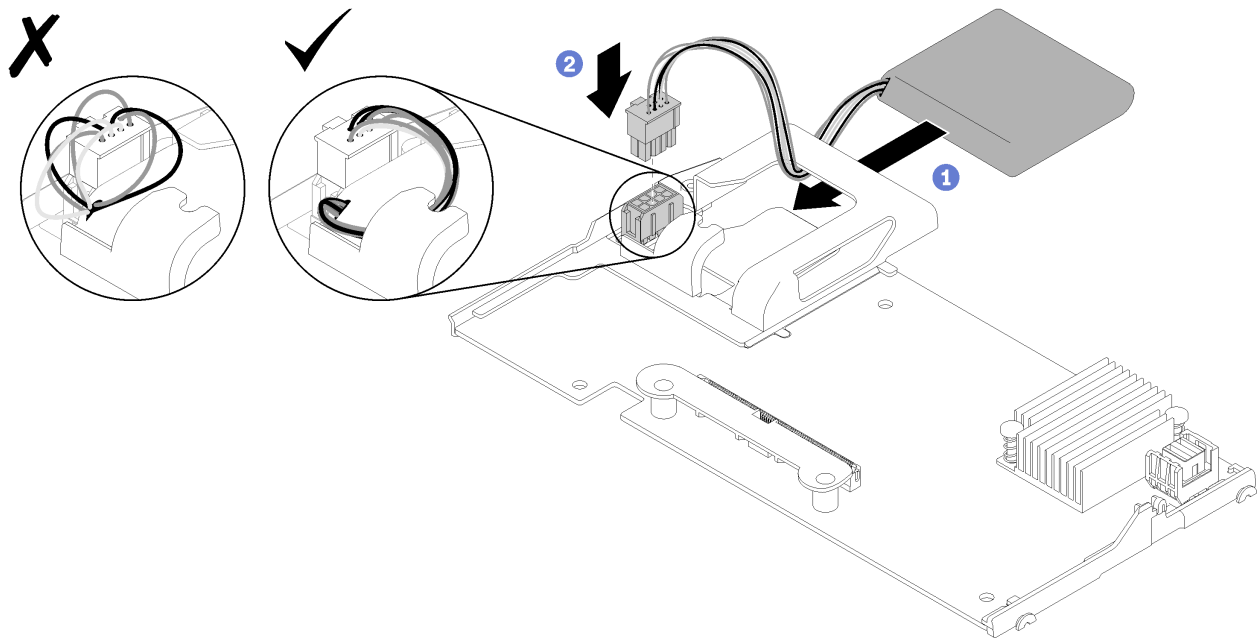

Figure 18. Flash power module installation

- Step 1. Orient the flash power module with the cable side facing the retaining clip on the RAID adapter; then, feed the cable up through the flash power module holder.
- Step 2. Slide the flash power module into the holder.
- Step 3. Connect the flash power module cable to its connector on the RAID adapter. The connector is keyed. Press the cable into the connector until the connector retaining clip snaps in place.
- Step 4. Route the flash power module cable through the notch in the holder; then, press the flash power module forward to seat it in the holder.

**Attention:** It is important to route the flash power module cable through the notch in holder to prevent the cable from catching on the DIMM connector latches when the RAID adapter is installed in a ThinkSystem node.

After you install the flash power module, complete the following steps:

1. Install the RAID adapter in the compute node. (see “Install a RAID adapter” on page 49).
2. Install the compute node cover (see “Install the compute node cover” on page 52 ).
3. Install the compute node into the chassis (see “Install the compute node in the chassis” on page 54 ).

## Install an I/O expansion adapter

Use this information to install an I/O expansion adapter option

Before you install an I/O expansion adapter, complete the following steps:

1. Read the safety information and guidelines to ensure that you work safely.
  - The safety information is available at:  
[http://thinksystem.lenovofiles.com/help/topic/safety\\_documentation/pdf\\_files.html](http://thinksystem.lenovofiles.com/help/topic/safety_documentation/pdf_files.html)
  - These guidelines are available as well: “Working inside the server with the power on” on page 27, and “Handling static-sensitive devices” on page 28.
2. Carefully lay the compute node on a flat, static-protective surface, orienting the compute node with the bezel pointing toward you.

3. Remove the compute node cover (see “Remove the top cover” on page 29).

This component can be installed as an optional device or as a CRU. The installation procedure is the same for the optional device and the CRU.

The optional Flex System PCIe Expansion Node supports additional PCIe adapters and I/O expansion adapters to provide a cost-effective way for you to increase and customize the capabilities of the compute node. For additional information, see "PCIe Expansion Node" at [http://flexsystem.lenovofiles.com/help/topic/com.lenovo.acc.pme.doc/product\\_page.html](http://flexsystem.lenovofiles.com/help/topic/com.lenovo.acc.pme.doc/product_page.html).

**Attention:** When installing an I/O adapter in one of the I/O expansion connectors, make sure the numbers in the Hexagon and Pentagon on the I/O expansion connector (see the service labeling on top of the compute node cover for details) corresponds to the particular shape and numbering of the I/O module bay on the Flex chassis (see the service labeling at the top on the rear of the chassis for details). If the correlation is incorrect, communication with the chassis may fail.

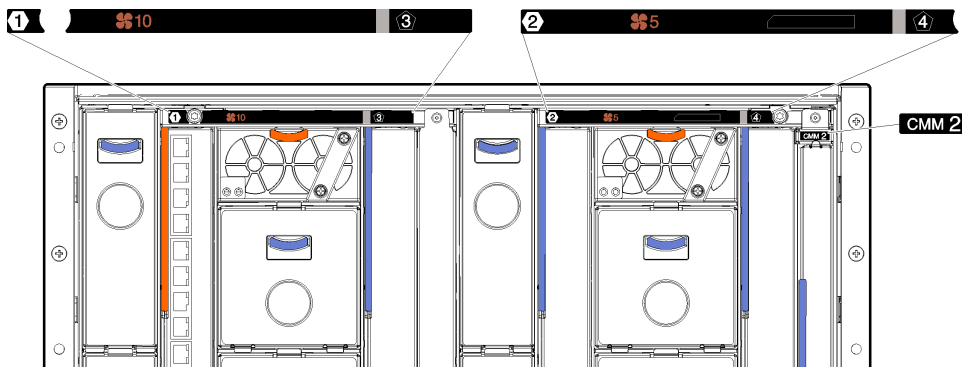

Figure 19. Service labeling on the rear of the chassis



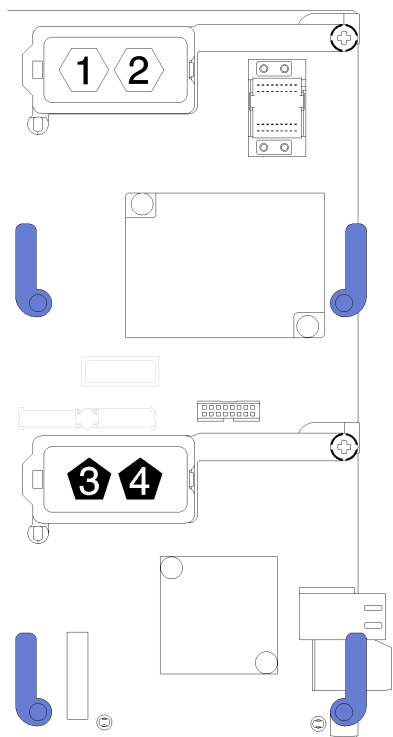

Figure 20. Hexagon and Pentagon number location on the I/O expansion connector

To install an I/O expansion adapter, complete the following steps:

**Watch the procedure.** A video of the installation process is available:

- Youtube: [https://www.youtube.com/playlist?list=PLYV5R7hVcs-B4\\_LYuT9X1MRWBU6UzX9gO](https://www.youtube.com/playlist?list=PLYV5R7hVcs-B4_LYuT9X1MRWBU6UzX9gO)
- Youku: [http://list.youku.com/albumlist/show/id\\_50481482](http://list.youku.com/albumlist/show/id_50481482)

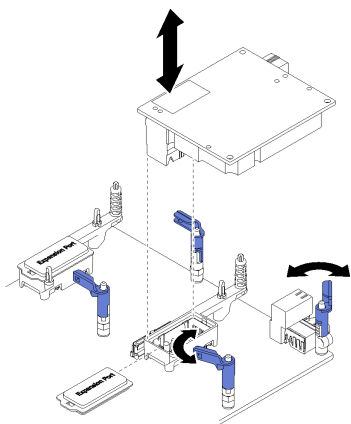

Figure 21. I/O expansion adapter installation

- Step 1. Locate the I/O expansion connectors.
- Step 2. Remove the expansion cover from the connector, if one is present.
- Step 3. Touch the static-protective package that contains the expansion adapter to any *unpainted* metal surface on the Lenovo Flex System chassis or any *unpainted* metal surface on any other grounded rack component; then, remove the expansion adapter from the package.
- Step 4. Rotate the retention clips outward.

- Step 5. Orient the connector on the expansion adapter with the I/O expansion connector and alignment pins on the system board; then, press the adapter into the I/O expansion connector.
- Step 6. Firmly press on the indicated locations to seat the expansion adapter in the connector and over the alignment pins.
- Step 7. Close the retention clips to secure the adapter.

After you install the I/O expansion adapter, complete the following steps:

1. Install the compute node cover (see “Install the compute node cover” on page 52 ).
2. Install the compute node into the chassis (see “Install the compute node in the chassis” on page 54 ).
3. See the documentation that comes with the expansion adapter for device-driver and configuration information to complete the installation.

## Install the M.2 backplane

Use this information to install the M.2 backplane.

Before you install the M.2 backplane, complete the following steps:

1. Read the safety information and guidelines to ensure that you work safely.
  - The safety information is available at:  
[http://thinksystem.lenovofiles.com/help/topic/safety\\_documentation/pdf\\_files.html](http://thinksystem.lenovofiles.com/help/topic/safety_documentation/pdf_files.html)
  - These guidelines are available as well: “Working inside the server with the power on” on page 27, and “Handling static-sensitive devices” on page 28.
2. Carefully lay the compute node on a flat, static-protective surface, orienting the compute node with the bezel pointing toward you.
3. Remove the compute node cover (see “Remove the top cover” on page 29).

To install the M.2 backplane, complete the following steps:

**Watch the procedure.** A video of the installation process is available:

- Youtube: [https://www.youtube.com/playlist?list=PLYV5R7hVcs-B4\\_LYuT9X1MRWBU6UzX9gO](https://www.youtube.com/playlist?list=PLYV5R7hVcs-B4_LYuT9X1MRWBU6UzX9gO)
- Youku: [http://list.youku.com/albumlist/show/id\\_50481482](http://list.youku.com/albumlist/show/id_50481482)

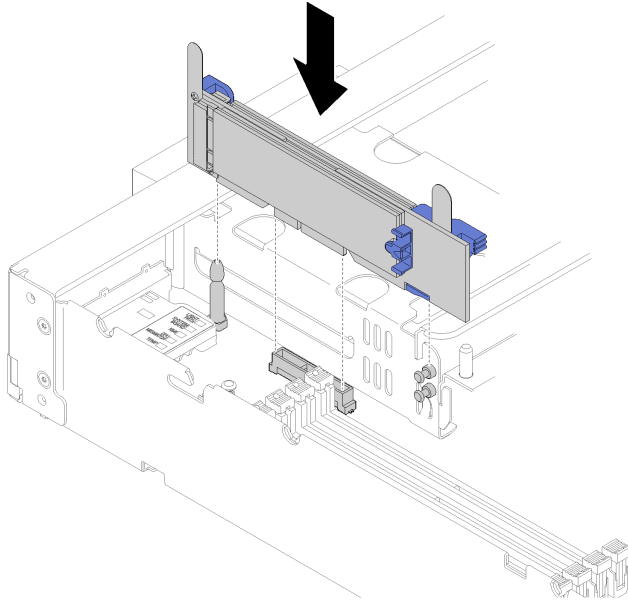

Figure 22. M.2 backplane installation

Step 1. Align the openings located at the bottom of the blue plastic supports at each end of the M.2 backplane with the guide pin on the system board and T-head pins on the hard drive cage; then, insert the backplane in the system board connector. Press down on the M.2 backplane to fully seat it.

After you install the M.2 backplane, complete the following steps:

1. Install the compute node cover (see “Install the compute node cover” on page 52 ).
2. Install the compute node into the chassis (see “Install the compute node in the chassis” on page 54 ).
3. See the documentation that comes with the M.2 backplane for device-driver and configuration information to complete the installation.

## Install an M.2 drive

Use this information to install an M.2 drive option.

Before you install an M.2 drive in the M.2 backplane, complete the following steps:

1. Read the safety information and guidelines to ensure that you work safely.
  - The safety information is available at:  
[http://thinksystem.lenovofiles.com/help/topic/safety\\_documentation/pdf\\_files.html](http://thinksystem.lenovofiles.com/help/topic/safety_documentation/pdf_files.html)
  - These guidelines are available as well: “Working inside the server with the power on” on page 27, and “Handling static-sensitive devices” on page 28.
2. Carefully lay the compute node on a flat, static-protective surface, orienting the compute node with the bezel pointing toward you.
3. Remove the compute node cover (see “Remove the top cover” on page 29).
4. Touch the static-protective package that contains the M.2 drive to any *unpainted* metal surface on the chassis or any *unpainted* metal surface on any other grounded rack component; then, remove the M.2 drive from the package.

5. Make sure the retainer on the M.2 backplane is in the correct keyhole to accommodate the particular size of the M.2 drive you wish to install (see “Adjust the position of the retainer on the M.2 backplane” on page 45).

To install an M.2 drive in the M.2 backplane, complete the following steps:

**Watch the procedure.** A video of the installation process is available:

- Youtube: [https://www.youtube.com/playlist?list=PLYV5R7hVcs-B4\\_LYuT9X1MRWBU6UzX9gO](https://www.youtube.com/playlist?list=PLYV5R7hVcs-B4_LYuT9X1MRWBU6UzX9gO)
- Youku: [http://list.youku.com/albumlist/show/id\\_50481482](http://list.youku.com/albumlist/show/id_50481482)

Step 1. Locate the connector on each side of the M.2 backplane.

**Notes:**

- Some M.2 backplanes support two identical M.2 drives. When two drives are installed, align and support both drives when sliding the retainer forward to secure the drives.
- Install the M.2 drive in slot 0 first.

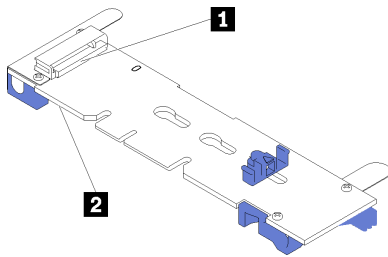

Figure 23. M.2 drive slot

Table 14. M.2 drive slot

1 Slot 0	2 Slot 1
----------	----------

Step 2. Insert the M.2 drive at an angle (approximately 30 degrees) into the connector and rotate it until the notch catches on the lip of the retainer; then, slide the retainer forward (toward the connector) to secure the M.2 drive in the M.2 backplane.

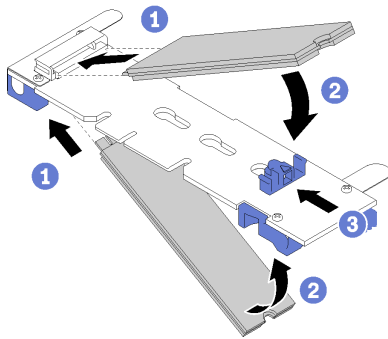

Figure 24. M.2 drive installation

**Attention:** When sliding the retainer forward, make sure the two nubs on the retainer enter the small holes on the M.2 backplane. Once they enter the holes, you will hear a soft “click” sound.

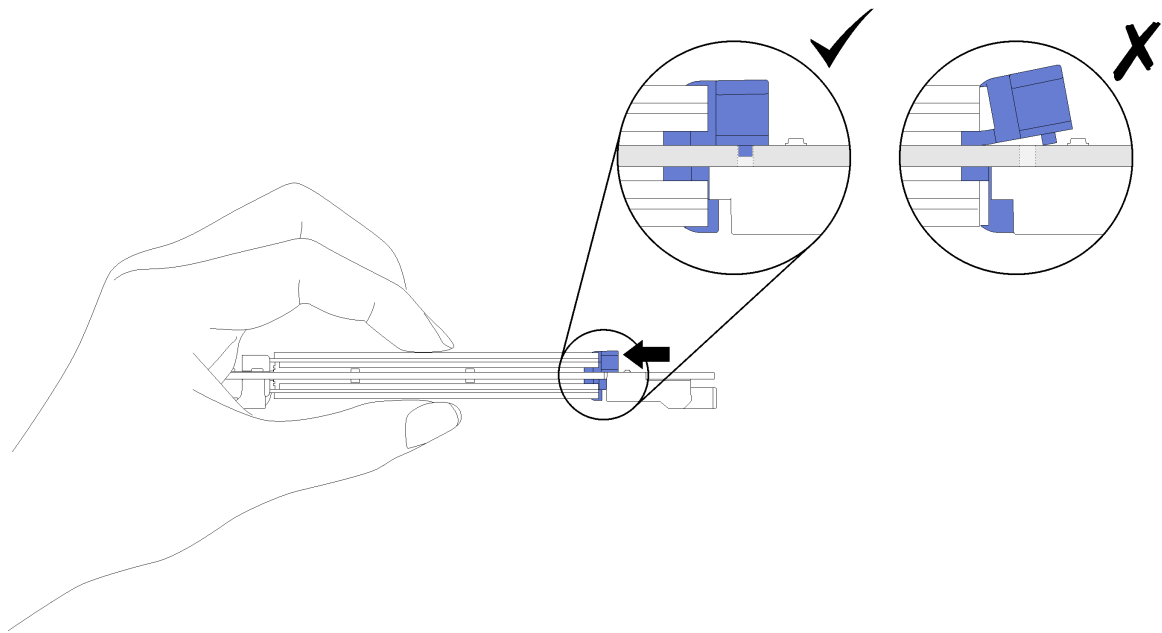

Figure 25. M.2 drive installation

After you install the M.2 drive into the M.2 backplane, complete the following steps:

1. Install the M.2 backplane (see “Install the M.2 backplane” on page 42).
2. Install the compute node cover (see “Install the compute node cover” on page 52 ).
3. Install the compute node into the chassis (see “Install the compute node in the chassis” on page 54 ).
4. See the documentation that comes with the expansion adapter for device-driver and configuration information to complete the installation.

### Adjust the position of the retainer on the M.2 backplane

Use this information to adjust the position of the retainer on the M.2 backplane.

Before you adjust the position of the retainer on the M.2 backplane, complete the following steps:

1. Read the safety information and guidelines to ensure that you work safely.
  - The safety information is available at:  
[http://thinksystem.lenovofiles.com/help/topic/safety\\_documentation/pdf\\_files.html](http://thinksystem.lenovofiles.com/help/topic/safety_documentation/pdf_files.html)
  - These guidelines are available as well: “Working inside the server with the power on” on page 27, and “Handling static-sensitive devices” on page 28.

To adjust the position of the retainer on the M.2 backplane, complete the following steps:

**Watch the procedure.** A video of the installation process is available:

- Youtube: [https://www.youtube.com/playlist?list=PLYV5R7hVcs-B4\\_LYuT9X1MRWBU6UzX9gO](https://www.youtube.com/playlist?list=PLYV5R7hVcs-B4_LYuT9X1MRWBU6UzX9gO)
- Youku: [http://list.youku.com/albumlist/show/id\\_50481482](http://list.youku.com/albumlist/show/id_50481482)

- Step 1. Locate the correct keyhole that the retainer should be installed into to accommodate the particular size of the M.2 drive you wish to install.
- Step 2. Press both sides of the retainer and move it forward until it is in the large opening of the keyhole; then, remove it from the backplane.
- Step 3. Insert the retainer into the correct keyhole and slide it backwards until the nubs are in the holes.

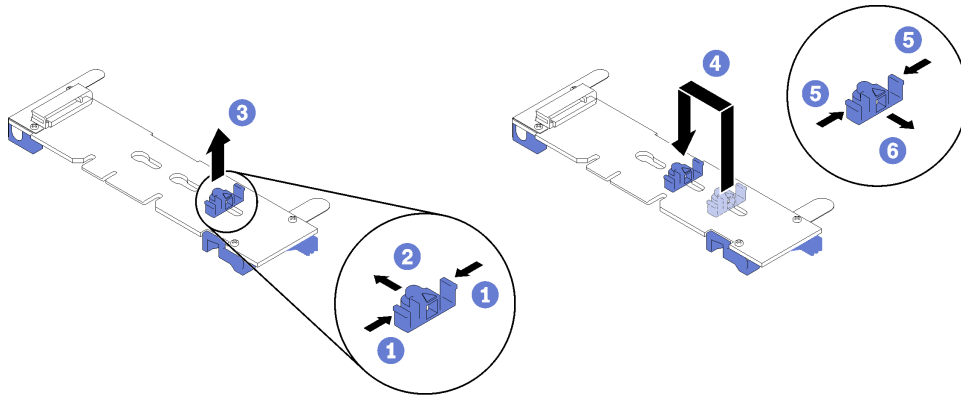

Figure 26. M.2 retainer adjustment

## Install a processor-heat-sink module

The processor and heat sink are removed together as part of a processor-heat-sink-module (PHM) assembly. PHM installation requires a Torx T30 driver.

**Note:** If you are installing multiple options relating to the compute system board, the PHM installation should be performed first.

### Attention:

- Each processor socket must always contain a cover or a PHM. When removing or installing a PHM, protect empty processor sockets with a cover.
- Do not touch the processor socket or processor contacts. Processor-socket contacts are very fragile and easily damaged. Contaminants on the processor contacts, such as oil from your skin, can cause connection failures.
- Remove and install only one PHM at a time. If the system board supports multiple processors, install the PHMs starting with the first processor socket.
- Do not allow the thermal grease on the processor or heat sink to come in contact with anything. Contact with any surface can compromise the thermal grease, rendering it ineffective. Thermal grease can damage components, such as electrical connectors in the processor socket. Do not remove the grease cover from a heat sink until you are instructed to do so.

### Notes:

- PHMs are keyed for the socket where they can be installed and for their orientation in the socket.
- See <http://www.lenovo.com/serverproven/> for a list of processors supported for your compute node. All processors on the system board must have the same speed, number of cores, and frequency.
- Before you install a new PHM or replacement processor, update your system firmware to the latest level. See “Update the firmware” on page 60.
- Installing an additional PHM can change the memory requirements for your system. See “Install a DIMM” on page 35 for a list of processor-to-memory relationships.
- Optional devices available for your system might have specific processor requirements. See the documentation that comes with the optional device for information.

Before installing a PHM:

**Note:** The PHM for your system might be different than the PHM shown in the illustrations.

1. Read the safety information and guidelines to ensure that you work safely.
  - The safety information is available at:  
[http://thinksystem.lenovofiles.com/help/topic/safety\\_documentation/pdf\\_files.html](http://thinksystem.lenovofiles.com/help/topic/safety_documentation/pdf_files.html)
  - These guidelines are available as well: “Working inside the server with the power on” on page 27, and “Handling static-sensitive devices” on page 28.

**Watch the procedure.** A video of the installation process is available:

- Youtube: [https://www.youtube.com/playlist?list=PLYV5R7hVcs-B4\\_LYuT9X1MRWBU6UzX9gO](https://www.youtube.com/playlist?list=PLYV5R7hVcs-B4_LYuT9X1MRWBU6UzX9gO)
  - Youku: [http://list.youku.com/albumlist/show/id\\_50481482](http://list.youku.com/albumlist/show/id_50481482)
2. Carefully lay the compute node on a flat, static-protective surface, orienting the compute node with the bezel pointing toward you.
  3. Remove the compute node cover (see “Remove the top cover” on page 29).
  4. Remove the air baffle. See “Remove the air baffle” on page 30.

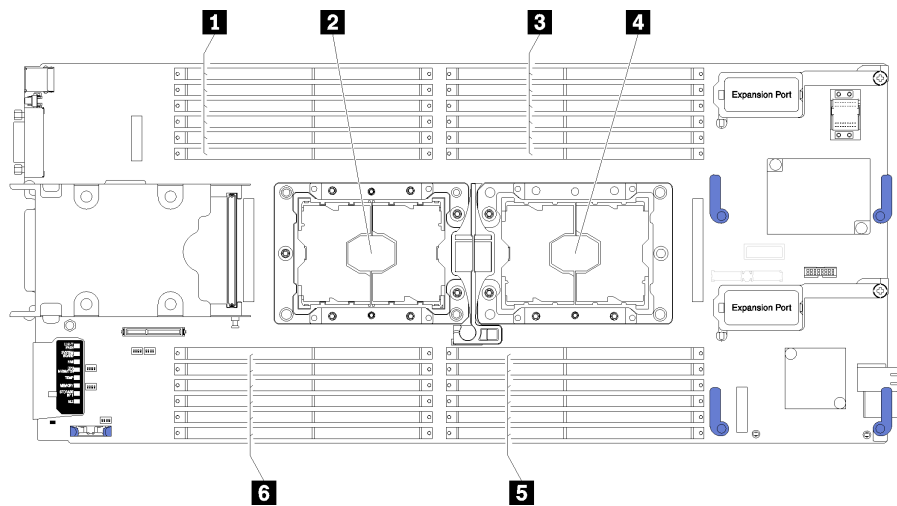

Figure 27. DIMM and processor location

Table 15. DIMM and processor location

<b>1</b> DIMM connectors 13–18	<b>4</b> Processor socket 1
<b>2</b> Processor socket 2	<b>5</b> DIMM connectors 7–12
<b>3</b> DIMM connectors 1–6	<b>6</b> DIMM connectors 19–24

Complete the following steps to install a PHM.

- Step 1. Remove the processor socket cover, if one is installed on the processor socket, by placing your fingers in the half-circles at each end of the cover and lifting it from the system board.
- Step 2. Install the processor-heat-sink module on the system board.





2. Carefully lay the compute node on a flat, static-protective surface, orienting the compute node with the bezel pointing toward you.
3. Remove the compute node cover (see “Remove the top cover” on page 29).

To install a RAID adapter, complete the following steps:

**Watch the procedure.** A video of the installation process is available:

- Youtube: [https://www.youtube.com/playlist?list=PLYV5R7hVcs-B4\\_LYuT9X1MRWBU6UzX9gO](https://www.youtube.com/playlist?list=PLYV5R7hVcs-B4_LYuT9X1MRWBU6UzX9gO)
- Youku: [http://list.youku.com/albumlist/show/id\\_50481482](http://list.youku.com/albumlist/show/id_50481482)

- Step 1. If a drive backplane is installed in the compute node that is not compatible with the RAID adapter, remove it (see “Remove the 2.5-inch drive backplane” on page 31).

**Note:** All drive backplanes use the same connector on the system board; however, there are two alignment slots in the drive cage to accommodate different backplane types. Make sure that you align the backplane and system board connectors when inserting the backplane in the drive cage.

- Step 2. If you are installing both the RAID adapter and drive backplane, first install the backplane in the system-board assembly (see “Install a 2.5-inch drive backplane” on page 33). The drive backplane goes in the rear alignment slots on the drive cage.

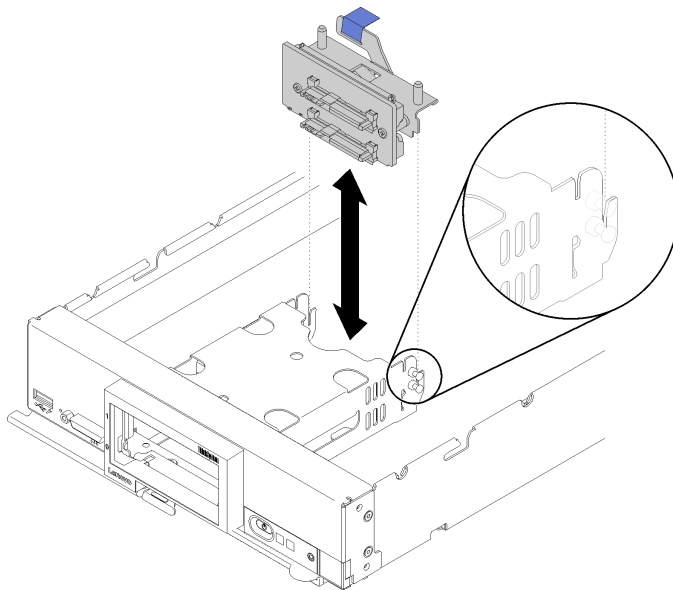
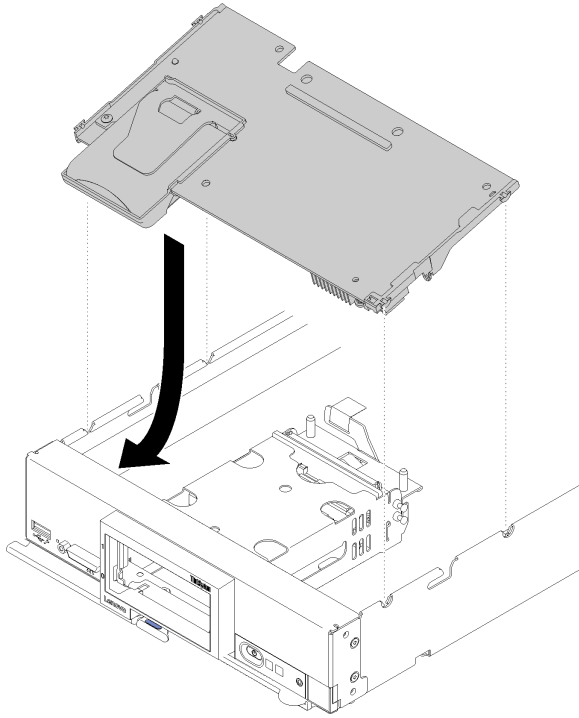

Figure 29. Drive backplane installation

- Step 3. Touch the static-protective package that contains the RAID adapter to an *unpainted* metal surface on any grounded rack component; then, remove the controller from the package.

**Note:** For the Lenovo ThinkSystem RAID 930-4i-2GB 2 Drive Adapter Kit, make sure that the flash power module is installed before installing the controller in the compute node (see “Install the flash power module” on page 38 ).

- Step 4. Locate the RAID adapter connector on the drive backplane.
- Step 5. Orient the connector on the RAID adapter with the connector on the drive backplane.



*Figure 30. RAID adapter installation*

Step 6. Firmly press on the foam to seat the RAID adapter into the connector.

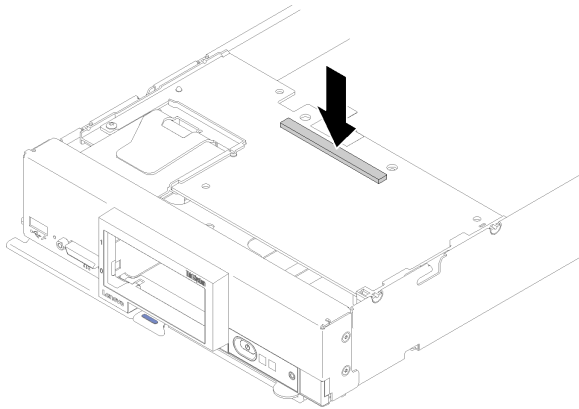

*Figure 31. RAID adapter installation*

After you install the RAID adapter, complete the following steps:

1. Install any removed storage drives and hard disk drive bay fillers (see “Install a 2.5-inch hot-swap drive” on page 34).

**Note:** Install storage drives in the same bay locations as from which they were removed.

2. Install the compute node cover (see “Install the compute node cover” on page 52 ).
3. Install the compute node into the chassis (see “Install the compute node in the chassis” on page 54 ).
4. Power on the compute node.
5. Configure the RAID array (see “RAID configuration” on page 67 ).

## Install the air baffle

Use this procedure to install the air baffle.

1. Read the safety information and guidelines to ensure that you work safely.
  - The safety information is available at:  
[http://thinksystem.lenovofiles.com/help/topic/safety\\_documentation/pdf\\_files.html](http://thinksystem.lenovofiles.com/help/topic/safety_documentation/pdf_files.html)
  - These guidelines are available as well: “Working inside the server with the power on” on page 27, and “Handling static-sensitive devices” on page 28.
2. Carefully lay the compute node on a flat, static-protective surface, orienting the compute node with the bezel pointing toward you.
3. Remove the compute node cover (see “Remove the top cover” on page 29).

To install the air baffle, complete the following steps:

**Watch the procedure.** A video of the installation process is available:

- Youtube: [https://www.youtube.com/playlist?list=PLYV5R7hVcs-B4\\_LYuT9X1MRWBU6UzX9gO](https://www.youtube.com/playlist?list=PLYV5R7hVcs-B4_LYuT9X1MRWBU6UzX9gO)
- Youku: [http://list.youku.com/albumlist/show/id\\_50481482](http://list.youku.com/albumlist/show/id_50481482)

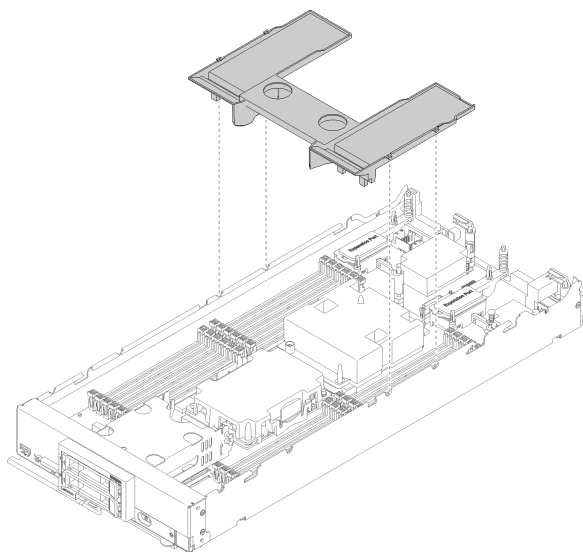

Figure 32. Air baffle installation

Step 1. Align the air baffle pins with the pin holes on both sides of the chassis; then, lower the air baffle into the compute node. Press the air baffle down until it is securely seated.

**Note:** Close the retaining clip on each end of the DIMM connector before installing the air baffle.

After you install the air baffle, complete the following steps:

1. Install the compute node cover (see “Install the compute node cover” on page 52).
2. Install the compute node into the chassis (see “Install the compute node in the chassis” on page 54 ).

## Install the compute node cover

Use this procedure to install the compute node cover.

Before installing the compute node cover:

1. Read the safety information and guidelines to ensure that you work safely.

- The safety information is available at:  
[http://thinksystem.lenovofiles.com/help/topic/safety\\_documentation/pdf\\_files.html](http://thinksystem.lenovofiles.com/help/topic/safety_documentation/pdf_files.html)
  - These guidelines are available as well: “Working inside the server with the power on” on page 27, and “Handling static-sensitive devices” on page 28.
2. Carefully lay the compute node on a flat, static-protective surface, orienting the compute node with the bezel pointing toward you.

**Attention:** You cannot insert the compute node into the Lenovo Flex System chassis until the cover is installed and closed. Do not attempt to override this protection.

**Statement 21**



**CAUTION:**

**Hazardous energy is present when the compute node is connected to the power source. Always replace the compute node cover before installing the compute node.**

**Watch the procedure.** A video of the installation process is available:

- Youtube: [https://www.youtube.com/playlist?list=PLYV5R7hVcs-B4\\_LYuT9X1MRWBU6UzX9gO](https://www.youtube.com/playlist?list=PLYV5R7hVcs-B4_LYuT9X1MRWBU6UzX9gO)
- Youku: [http://list.youku.com/albumlist/show/id\\_50481482](http://list.youku.com/albumlist/show/id_50481482)

Step 1. Orient the cover so that the posts on the inside of the cover slide into the slots on the compute node.

**Note:** Before you close the cover, make sure that the air baffle and all components are installed and seated correctly and that you have not left loose tools or parts inside the compute node. Retention clips that secure the I/O expansion adapters must be in the closed position to install the cover.

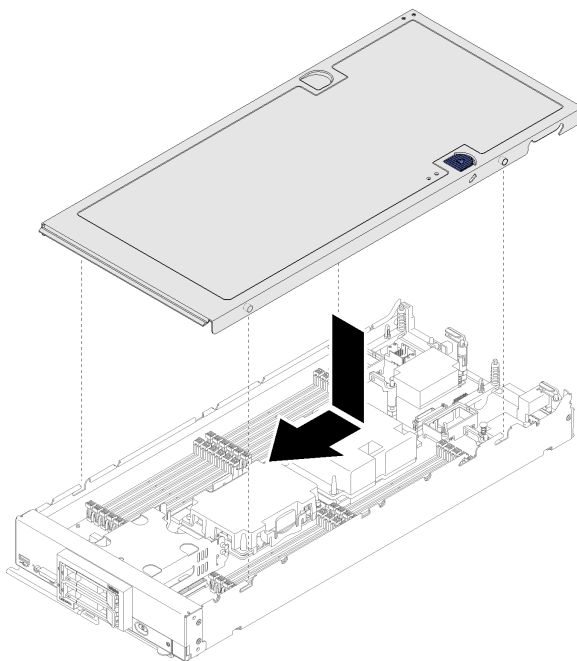

*Figure 33. Compute node cover installation*

Step 2. Hold the front of the compute node and slide the cover forward to the closed position, until it clicks into place.

1. Install the compute node into the chassis (see “Install the compute node in the chassis” on page 54 ).

---

## Install the compute node in the chassis

Use this information to install the compute node in the chassis.

Before you install the compute node in the chassis:

1. Read the safety information and guidelines to ensure that you work safely.
  - The safety information is available at:  
[http://thinksystem.lenovofiles.com/help/topic/safety\\_documentation/pdf\\_files.html](http://thinksystem.lenovofiles.com/help/topic/safety_documentation/pdf_files.html)
  - These guidelines are available as well: “Working inside the server with the power on” on page 27, and “Handling static-sensitive devices” on page 28.

### S021



#### **CAUTION:**

**Hazardous energy is present when the blade is connected to the power source. Always replace the blade cover before installing the blade.**

To install the compute node in a chassis, complete the following steps:

**Watch the procedure.** A video of the installation process is available:

- Youtube: [https://www.youtube.com/playlist?list=PLYV5R7hVcs-B4\\_LYuT9X1MRWBU6UzX9gO](https://www.youtube.com/playlist?list=PLYV5R7hVcs-B4_LYuT9X1MRWBU6UzX9gO)
- Youku: [http://list.youku.com/albumlist/show/id\\_50481482](http://list.youku.com/albumlist/show/id_50481482)

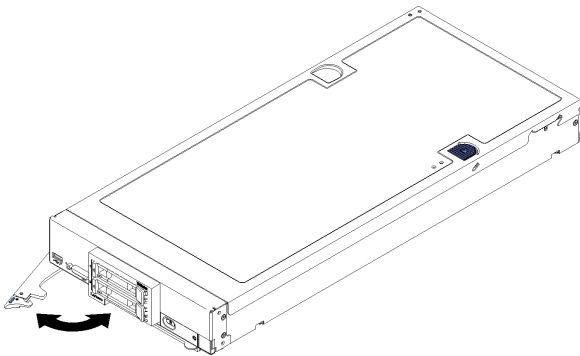

*Figure 34. Compute node installation in chassis*

Step 1. Select the node bay.

#### **Notes:**

1. If you are reinstalling a compute node that you removed, you must install it in the same node bay from which you removed it. Some compute node configuration information and update options are established according to node bay number. Reinstalling a compute node into a different node bay can have unintended consequences. If you reinstall the compute node into a different node bay, you might have to reconfigure the compute node.

2. To maintain proper system cooling, do not operate the Lenovo Flex System chassis without a compute node, or node bay filler in each node bay.

Step 2. Make sure that the front handle on the compute node is in the fully open position.

Step 3. Slide the compute node into the node bay until it stops.

Step 4. Push the front handle on the front of the compute node to the closed position.

**Note:** After the compute node is installed, the Lenovo XClarity Controller in the compute node initializes and synchronizes with the Chassis Management Module. The time required for a compute node to initialize varies by system configuration. The power LED flashes rapidly; the power button on the compute node does not respond until the power LED flashes slowly, indicating that the initialization process is complete.

Step 5. Turn on the compute node.

**Important:** If an Attention label is on the front panel of the compute node above the power button, read it; then, remove the label and discard it before turning on the compute node.

Step 6. Make sure that the power LED on the compute node control panel is lit continuously, indicating that the compute node is receiving power and is turned on.

Step 7. If you have other compute nodes to install, do so now.

If this is the initial installation of the compute node in the chassis, you must configure the compute node through the Setup utility and install the compute node operating system. See Chapter 4 “System configuration” on page 59 for details.

If you have changed the configuration of the compute node or if you are installing a different compute node from the one that you removed, you must configure the compute node through the Setup utility, and you might have to install the compute node operating system. See Chapter 4 “System configuration” on page 59 for details.

- For instructions related to the Flex System Enterprise chassis, see [http://flexsystem.lenovofiles.com/help/topic/com.lenovo.acc.8721.doc/installing\\_components.html](http://flexsystem.lenovofiles.com/help/topic/com.lenovo.acc.8721.doc/installing_components.html).
- For instructions related to the Flex System Carrier-Grade chassis, see [http://flexsystem.lenovofiles.com/help/topic/com.lenovo.acc.7385.doc/installing\\_components.html](http://flexsystem.lenovofiles.com/help/topic/com.lenovo.acc.7385.doc/installing_components.html).

---

## Power on the compute node

Use this information for details about power on the compute node.

After you connect the compute node to power through the Lenovo Flex System chassis, the compute node can be started in any of the following ways.

**Important:** If an Attention label is on the front panel of the compute node above the power button, read it; then, remove the label and discard it before turning on the compute node.

- You can press the power button on the front of the compute node to start the compute node. The power button works only if local power control is enabled for the compute node. Local power control is enabled and disabled through the CMM **power** command and the CMM web interface.
  - For more information about the CMM **power** command, see the *Flex System Chassis Management Module: Command-Line Interface Reference Guide* at [http://flexsystem.lenovofiles.com/help/topic/com.lenovo.acc.cmm.doc/cli\\_command\\_power.html](http://flexsystem.lenovofiles.com/help/topic/com.lenovo.acc.cmm.doc/cli_command_power.html).
  - From the CMM web interface, select **Compute Nodes** from the **Chassis Management** menu. For more information, see the “Flex System Chassis Management Module: User’s Guide” at [http://flexsystem.lenovofiles.com/help/topic/com.lenovo.acc.cmm.doc/cmm\\_user\\_guide.html](http://flexsystem.lenovofiles.com/help/topic/com.lenovo.acc.cmm.doc/cmm_user_guide.html). All fields and options are described in the CMM web interface online help.

## Notes:

1. Wait until the power LED on the compute node flashes slowly before you press the power button. While the Lenovo XClarity Controller in the compute node is initializing and synchronizing with the Chassis Management Module, the power LED flashes rapidly, and the power button on the compute node does not respond. The time required for a compute node to initialize varies by system configuration; however, the power LED blink rate slows when the compute node is ready to be turned on.
  2. While the compute node is starting, the power LED on the front of the compute node is lit and does not flash.
- If a power failure occurs, the Lenovo Flex System chassis and the compute node can be configured through the CMM **power** command and the CMM web interface to start automatically when power is restored.
    - For more information about the CMM **power** command, see the *Flex System Chassis Management Module: Command-Line Interface Reference Guide* at [http://flexsystem.lenovofiles.com/help/topic/com.lenovo.acc.cmm.doc/cli\\_command\\_power.html](http://flexsystem.lenovofiles.com/help/topic/com.lenovo.acc.cmm.doc/cli_command_power.html).
    - From the CMM web interface, select **Compute Nodes** from the **Chassis Management** menu. For more information, see the "Flex System Chassis Management Module: User's Guide" at [http://flexsystem.lenovofiles.com/help/topic/com.lenovo.acc.cmm.doc/cmm\\_user\\_guide.html](http://flexsystem.lenovofiles.com/help/topic/com.lenovo.acc.cmm.doc/cmm_user_guide.html). All fields and options are described in the CMM web interface online help.
  - You can turn on the compute node through the CMM **power** command, the CMM web interface and the Lenovo XClarity Administrator application (if installed).
    - For more information about the CMM **power** command, see the *Flex System Chassis Management Module: Command-Line Interface Reference Guide* at [http://flexsystem.lenovofiles.com/help/topic/com.lenovo.acc.cmm.doc/cli\\_command\\_power.html](http://flexsystem.lenovofiles.com/help/topic/com.lenovo.acc.cmm.doc/cli_command_power.html).
    - From the CMM web interface, select **Compute Nodes** from the **Chassis Management** menu. For more information, see the "Flex System Chassis Management Module: User's Guide" at [http://flexsystem.lenovofiles.com/help/topic/com.lenovo.acc.cmm.doc/cmm\\_user\\_guide.html](http://flexsystem.lenovofiles.com/help/topic/com.lenovo.acc.cmm.doc/cmm_user_guide.html). All fields and options are described in the CMM web interface online help.
    - For more information about the Lenovo XClarity Administrator application, see <https://support.lenovo.com/us/en/documents/LNVO-XCLARIT>.
  - You can turn on the compute node through the Wake on LAN (WOL) feature when an optional I/O adapter with WOL capability is installed. The compute node must be connected to power (the power LED is flashing slowly) and must be communicating with the Chassis Management Module. The operating system must support the Wake on LAN feature, and the Wake on LAN feature must be enabled through the Chassis Management Module interface.

---

## Validate compute node setup

After powering up the compute node, make sure that the LEDs are lit and that they are green.

---

## Power off the compute node

Use this information for details about turning off the compute node.

When you turn off the compute node, it is still connected to power through the Lenovo Flex System chassis. The compute node can respond to requests from the XClarity Controller, such as a remote request to turn on the compute node. To remove all power from the compute node, you must remove it from the Lenovo Flex System chassis.

Before you turn off the compute node, shut down the operating system. See the operating-system documentation for information about shutting down the operating system.



The compute node can be turned off in any of the following ways:

- You can press the power button on the compute node. This starts an orderly shutdown of the operating system, if this feature is supported by the operating system.
- If the operating system stops functioning, you can press and hold the power button for more than four seconds to turn off the compute node.

**Attention:** Pressing the power button for 4 seconds forces the operating system to shut down immediately. Data loss is possible.

- You can turn off the compute node through the CMM **power** command, the CMM web interface and the Lenovo XClarity Administrator application (if installed).
  - For more information about the CMM **power** command, see the *Flex System Chassis Management Module: Command-Line Interface Reference Guide* at [http://flexsystem.lenovofiles.com/help/topic/com.lenovo.acc.cmm.doc/cli\\_command\\_power.html](http://flexsystem.lenovofiles.com/help/topic/com.lenovo.acc.cmm.doc/cli_command_power.html).
  - From the CMM web interface, select **Compute Nodes** from the **Chassis Management** menu. For more information, see the "Flex System Chassis Management Module: User's Guide" at [http://flexsystem.lenovofiles.com/help/topic/com.lenovo.acc.cmm.doc/cmm\\_user\\_guide.html](http://flexsystem.lenovofiles.com/help/topic/com.lenovo.acc.cmm.doc/cmm_user_guide.html). All fields and options are described in the CMM web interface online help.
  - For more information about the Lenovo XClarity Administrator application, see <https://support.lenovo.com/us/en/documents/LNVO-XCLARIT>.



---

## Chapter 4. System configuration

Complete these procedures to configure your system.

---

### Set the network connection for the Lenovo XClarity Controller

Before you can access the Lenovo XClarity Controller over your network, you need to specify how Lenovo XClarity Controller will connect to the network. Depending on how the network connection is implemented, you might need to specify a static IP address as well.

The procedure for setting the network connection will depend on whether or not you have a video connection to the server.

- If a monitor is attached to the server, you can use Lenovo XClarity Controller to set the network connection.
- If no monitor is attached to the server, you can set the network connection through the Chassis Management Module.
  1. Make sure that the subnet of your computer is set to the same value as the CMM (the default CMM subnet is 255.255.255.0). The IP address of the CMM must also be in the same local domain as the client computer. To connect to the CMM for the first time, you might have to change the Internet Protocol properties on the client computer.
  2. Connect an Ethernet cable from your laptop to the management port on the CMM.
  3. Open a web browser on the client computer, and direct it to the CMM IP address. For the first connection to the CMM, use the default IP address of the CMM; if a new IP address has been assigned to the CMM, use that one instead.

**Note:** The manufacturing default static IPv4 IP address is 192.168.70.100, the default IPv4 subnet address is 255.255.255.0, and the default host name is MMxxxxxxxxxxx, where xxxxxxxxxxxx is the burned-in MAC address. The MAC address is on a label on the CMM, below the reset button (see CMM controls and indicators for the reset button location). See IPv6 addressing for initial connection for information about determining IPv6 addressing for the initial connection.

4. After logging in to the CMM, click **Chassis Management** → **Compute Nodes** to set the IP address of the compute node.

**Important:** The Lenovo XClarity Controller is set initially with a user name of USERID and password of PASSWORD (with a zero, not the letter O). This default user setting has Supervisor access. Change this user name and password during your initial configuration for enhanced security.

You can use the Lenovo XClarity Administrator Mobile app to connect to the Lenovo XClarity Controller interface and configure the network address. For additional information about the Mobile app, see the following site:

[http://sysmgt.lenovofiles.com/help/topic/com.lenovo.lxca.doc/lxca\\_usemobileapp.html](http://sysmgt.lenovofiles.com/help/topic/com.lenovo.lxca.doc/lxca_usemobileapp.html)

Complete the following steps to connect the Lenovo XClarity Controller to the network using the Lenovo XClarity Provisioning Manager.

- Step 1. Start the server.
- Step 2. When you see <F1> Setup, press F1.
- Step 3. Specify how the Lenovo XClarity Controller will connect to the network.

- If you choose a static IP connection, make sure that you specify an IPv4 or IPv6 address that is available on the network.
- If you choose a DHCP connection, make sure that the MAC address for the server has been configured in the DHCP server.

Step 4. Click **OK** to continue starting the server.

## Update the firmware

Several options are available to update the firmware for the server.

You can use the tools listed here to update the most current firmware for your server and the devices that are installed in the server.

**Note:** Lenovo typically releases firmware in bundles called UpdateXpress System Packs (UXSPs). To ensure that all of the firmware updates are compatible, you should update all firmware at the same time. If you are updating firmware for both the Lenovo XClarity Controller and UEFI, update the firmware for Lenovo XClarity Controller first.

### Important terminology

- **In-band update.** The installation or update is performed using a tool or application within an operating system that is executing on the server's core CPU.
- **Out-of-band update.** The installation or update is performed by the Lenovo XClarity Controller collecting the update and then directing the update to the target subsystem or device. Out-of-band updates have no dependency on an operating system executing on the core CPU. However, most out-of-band operations do require the server to be in the S0 (Working) power state.
- **On-Target update.** The installation or update is initiated from an Operating System executing on the server's operating system.
- **Off-Target update.** The installation or update is initiated from a computing device interacting directly with the server's Lenovo XClarity Controller.
- **UpdateXpress System Packs (UXSPs).** UXSPs are bundled updates designed and tested to provide the interdependent level of functionality, performance, and compatibility. UXSPs are server machine-type specific and are built (with firmware and device driver updates) to support specific Windows Server, Red Hat Enterprise Linux (RHEL) and SUSE Linux Enterprise Server (SLES) operating system distributions. Machine-type-specific firmware-only UXSPs are also available.

See the following table to determine the best Lenovo tool to use for installing and setting up the firmware:

Tool	In-band update	Out-of-band update	On-target update	Off-target update	Graphical user interface	Command-line interface	Supports UXSPs
<b>Lenovo XClarity Provisioning Manager</b>  Limited to core system firmware only.	√			√	√		√
<b>Lenovo XClarity Controller</b>  Supports core system firmware and most advanced I/O option firmware updates		√		√	√	√	

Tool	In-band update	Out-of-band update	On-target update	Off-target update	Graphical user interface	Command-line interface	Supports UXSPs
<b>Lenovo XClarity Essentials OneCLI</b>  Supports all core system firmware, I/O firmware, and installed operating system driver updates	√	√				√	√
<b>Lenovo XClarity Essentials UpdateXpress</b>  Supports all core system firmware, I/O firmware, and installed operating system driver updates	√	√			√		√
<b>Lenovo XClarity Administrator</b>  Supports core system firmware and I/O firmware updates	√	√		√	√		

The latest firmware can be found at the following site:

<http://datacentersupport.lenovo.com/products/servers/thinksystem/sn550/7X16/downloads>

- **Lenovo XClarity Provisioning Manager**

From Lenovo XClarity Provisioning Manager, you can update the Lenovo XClarity Controller firmware, the UEFI firmware, and the Lenovo XClarity Provisioning Manager software.

**Note:** By default, the Lenovo XClarity Provisioning Manager Graphical User Interface is displayed when you press F1. If you have changed that default to be the text-based system setup, you can bring up the Graphical User Interface from the text-based system setup interface.

Additional information about using Lenovo XClarity Provisioning Manager to update firmware is available at:

[http://sysmgt.lenovofiles.com/help/topic/LXPM/platform\\_update.html](http://sysmgt.lenovofiles.com/help/topic/LXPM/platform_update.html)

- **Lenovo XClarity Controller**

If you need to install a specific update, you can use the Lenovo XClarity Controller interface for a specific server.

**Notes:**

- To perform an in-band update through Windows or Linux, the operating system driver must be installed and the Ethernet-over-USB (sometimes called LAN over USB) interface must be enabled.

Additional information about configuring Ethernet over USB is available at:

[http://sysmgt.lenovofiles.com/help/topic/com.lenovo.systems.management.xcc.doc/NN1ia\\_c\\_configuringUSB.html](http://sysmgt.lenovofiles.com/help/topic/com.lenovo.systems.management.xcc.doc/NN1ia_c_configuringUSB.html)

- If you update firmware through the Lenovo XClarity Controller, make sure that you have downloaded and installed the latest device drivers for the operating system that is running on the server.

Specific details about updating firmware using Lenovo XClarity Controller are available at:

[http://sysmgt.lenovofiles.com/help/topic/com.lenovo.systems.management.xcc.doc/NN1ia\\_c\\_manageserverfirmware.html](http://sysmgt.lenovofiles.com/help/topic/com.lenovo.systems.management.xcc.doc/NN1ia_c_manageserverfirmware.html)

- **Lenovo XClarity Essentials OneCLI**

Lenovo XClarity Essentials OneCLI is a collection of command line applications that can be used to manage Lenovo servers. Its update application can be used to update firmware and device drivers for your servers. The update can be performed within the host operating system of the server (in-band) or remotely through the BMC of the server (out-of-band).

Specific details about updating firmware using Lenovo XClarity Essentials OneCLI is available at:

[http://sysmgt.lenovofiles.com/help/topic/toolsctr\\_cli\\_lenovo/onecli\\_c\\_update.html](http://sysmgt.lenovofiles.com/help/topic/toolsctr_cli_lenovo/onecli_c_update.html)

- **Lenovo XClarity Essentials UpdateXpress**

Lenovo XClarity Essentials UpdateXpress provides most of OneCLI update functions through a graphical user interface (GUI). It can be used to acquire and deploy UpdateXpress System Pack (UXSP) update packages and individual updates. UpdateXpress System Packs contain firmware and device driver updates for Microsoft Windows and for Linux.

You can obtain Lenovo XClarity Essentials UpdateXpress from the following location:

<https://datacentersupport.lenovo.com/us/en/solutions/ht503692>

- **Lenovo XClarity Administrator**

If you are managing multiple servers using the Lenovo XClarity Administrator, you can update firmware for all managed servers through that interface. Firmware management is simplified by assigning firmware-compliance policies to managed endpoints. When you create and assign a compliance policy to managed endpoints, Lenovo XClarity Administrator monitors changes to the inventory for those endpoints and flags any endpoints that are out of compliance.

Specific details about updating firmware using Lenovo XClarity Administrator are available at:

[http://sysmgt.lenovofiles.com/help/topic/com.lenovo.lxca.doc/update\\_fw.html](http://sysmgt.lenovofiles.com/help/topic/com.lenovo.lxca.doc/update_fw.html)

---

## Configure the firmware

Several options are available to install and set up the firmware for the server.

- **Lenovo XClarity Provisioning Manager**

From Lenovo XClarity Provisioning Manager, you can configure the UEFI settings for your server.

**Note:** The Lenovo XClarity Provisioning Manager provides a Graphical User Interface to configure a server. The text-based interface to system configuration (the Setup Utility) is also available. From Lenovo XClarity Provisioning Manager, you can choose to restart the server and access the text-based interface. In addition, you can choose to make the text-based interface the default interface that is displayed when you press F1.

- **Lenovo XClarity Essentials OneCLI**

You can use the config application and commands to view the current system configuration settings and make changes to Lenovo XClarity Controller and UEFI. The saved configuration information can be used to replicate or restore other systems.

For information about configuring the server using Lenovo XClarity Essentials OneCLI, see:

[http://sysmgt.lenovofiles.com/help/topic/toolsctr\\_cli\\_lenovo/onecli\\_c\\_settings\\_info\\_commands.html](http://sysmgt.lenovofiles.com/help/topic/toolsctr_cli_lenovo/onecli_c_settings_info_commands.html)

- **Lenovo XClarity Administrator**

You can quickly provision and pre-provision all of your servers using a consistent configuration. Configuration settings (such as local storage, I/O adapters, boot settings, firmware, ports, and Lenovo XClarity Controller and UEFI settings) are saved as a server pattern that can be applied to one or more managed servers. When the server patterns are updated, the changes are automatically deployed to the applied servers.

Specific details about updating firmware using Lenovo XClarity Administrator are available at:

[http://sysmgt.lenovofiles.com/help/topic/com.lenovo.lxca.doc/server\\_configuring.html](http://sysmgt.lenovofiles.com/help/topic/com.lenovo.lxca.doc/server_configuring.html)

- **Lenovo XClarity Controller**

You can configure the management processor for the server through the Lenovo XClarity Controller Web interface or through the command-line interface.

For information about configuring the server using Lenovo XClarity Controller, see:

[http://sysmgt.lenovofiles.com/help/topic/com.lenovo.systems.management.xcc.doc/NN1ia\\_c\\_manageserverfirmware.html](http://sysmgt.lenovofiles.com/help/topic/com.lenovo.systems.management.xcc.doc/NN1ia_c_manageserverfirmware.html)

## DIMM configuration

Memory performance depends on several variables, such as memory mode, memory speed, memory ranks, memory population and processor.

Information about optimizing memory performance and configuring memory is available at the Lenovo Press website:

<https://lenovopress.com/servers/options/memory>

In addition, you can take advantage of a memory configurator, which is available at the following site:

[http://lesc.lenovo.com/ss/#/memory\\_configuration](http://lesc.lenovo.com/ss/#/memory_configuration)

Specific information about the required installation order of memory modules in your compute node based on the system configuration and memory mode that you are implementing is shown below.

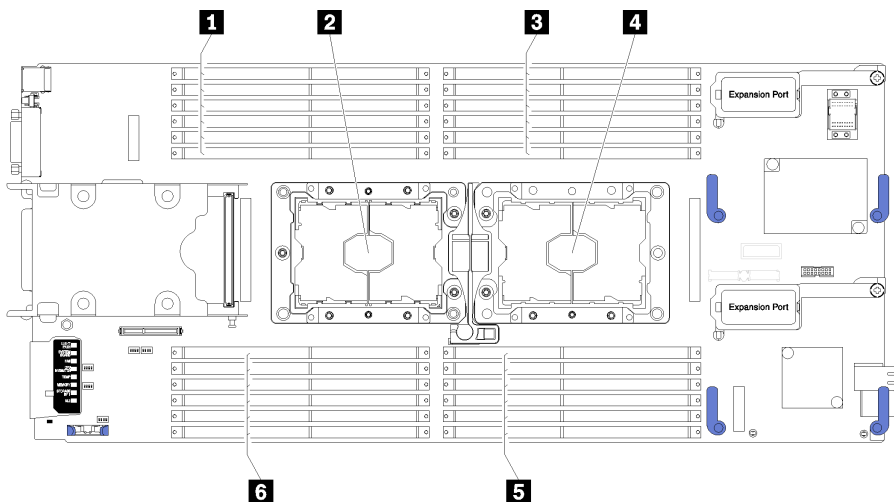

Figure 35. DIMM and processor location

Table 16. DIMM and processor location

<b>1</b> DIMM connectors 13–18	<b>4</b> Processor socket 1
<b>2</b> Processor socket 2	<b>5</b> DIMM connectors 7–12
<b>3</b> DIMM connectors 1–6	<b>6</b> DIMM connectors 19–24

Table 17. Channel and slot information of DIMMs around processor 1 and 2

The memory-channel configuration table is a three-column table that shows the relationship between the processors, memory controllers, memory channels, slot number and the DIMM connectors.

Integrated Memory Controller (iMC)	Controller 0						Controller 1					
	Channel 2		Channel 1		Channel 0		Channel 0		Channel 1		Channel 2	
Channel												
Slot	0	1	0	1	0	1	1	0	1	0	1	0
DIMM connector (processor 1)	1	2	3	4	5	6	7	8	9	10	11	12
DIMM connector (processor 2)	24	23	22	21	20	19	18	17	16	15	14	13

## Independent memory mode

Independent memory mode provides high performance memory capability. The memory channels can be populated with DIMMs in any order in independent mode. You can populate all six channels on each processor in any order with no matching requirements. Individual channels can run at different DIMM timings, but all channels must run at the same interface frequency.

If a memory channel has two DIMMs, populate the DIMM with a higher number of ranks in slot 0. If the ranks are the same, populate the one with higher capacity in slot 0.

Table 18. DIMM population sequence for independent-channel mode (DIMM 1-12)

Number of installed DIMMs	1 processor installed	2 processors installed
	DIMM connector	DIMM connector
1	5	—
2	5, 8	5, 20
3	5, 8, 3	5, 20, 8
4	5, 8, 3, 10	5, 20, 8, 17
5	5, 8, 3, 10, 1	5, 20, 8, 17, 3
6	5, 8, 3, 10, 1, 12	5, 20, 8, 17, 3, 22
7	3, 5, 8, 10, 12, 4, 6	5, 20, 8, 17, 3, 22, 10
8	3, 4, 5, 6, 8, 10, 7, 9	5, 20, 8, 17, 3, 22, 10, 15
9	3, 4, 5, 6, 8, 10, 12, 1, 2	5, 20, 8, 17, 3, 22, 10, 15, 1
10	1, 2, 3, 4, 5, 6, 8, 10, 7, 9	5, 20, 8, 17, 3, 22, 10, 15, 1, 24
11	1, 2, 3, 4, 5, 6, 7, 8, 9, 10, 12	5, 20, 8, 17, 3, 22, 10, 15, 1, 24, 12
12	1, 2, 3, 4, 5, 6, 7, 8, 9, 10, 12, 11	5, 20, 8, 17, 3, 22, 10, 15, 1, 24, 12, 13
13	Not used - maximum of 12 DIMMs in systems with 1 processor	See Table 19 “DIMM population sequence for independent-channel mode” on page 65 for configuration with greater than 12 DIMMs



Table 19. DIMM population sequence for independent-channel mode

Number of installed DIMMs	2 processors installed
	DIMM connector
13	3, 4, 5, 6, 8, 10, 12, 24, 22, 20, 17, 15, 13
14	3, 4, 5, 6, 8, 10, 12, 22, 20, 17, 15, 13, <b>21, 19</b>
15	3, 4, 5, 6, 8, 10, 15, 16, 17, 18, 20, 22, 24, <b>7, 9</b>
16	3, 4, 5, 6, 7, 8, 9, 10, 22, 21, 20, 19, 17, 15, <b>18, 16</b>
17	3, 4, 5, 6, 8, 10, 12, 22, 21, 20, 19, 18, 17, 16, 15, <b>1, 2</b>
18	1, 2, 3, 4, 5, 6, 8, 10, 12, 22, 21, 20, 19, 17, 15, <b>24, 23, 13</b>
19	1, 2, 3, 4, 5, 6, 8, 10, 24, 23, 22, 21, 20, 19, 17, 15, 13, <b>7, 9</b>
20	1, 2, 3, 4, 5, 6, 7, 8, 9, 10, 24, 23, 22, 21, 20, 19, 17, 15, <b>18, 16</b>
21	1, 2, 3, 4, 5, 6, 7, 8, 9, 10, 24, 23, 22, 21, 20, 19, 17, 15, <b>11, 12, 13</b>
22	1, 2, 3, 4, 5, 6, 7, 8, 9, 10, 12, 24, 23, 22, 21, 20, 19, 17, 15, 13, <b>18, 16</b>
23	1, 2, 3, 4, 5, 6, 7, 8, 9, 10, 11, 12, 24, 23, 22, 21, 20, 19, 18, 17, 16, 15, <b>13</b>
24	1, 2, 3, 4, 5, 6, 7, 8, 9, 10, 11, 12, 24, 23, 22, 21, 20, 19, 18, 17, 16, 15, 13, <b>14</b>

## Memory mirroring

In mirrored-channel mode, mirroring of the memory is done between Channels 0, 1, and 2 or Channels 3, 4, and 5. One channel is used as a backup of the other, which provides redundancy. The memory contents on channel 0 are duplicated in channel 1, and the memory contents of channel 2 are duplicated in channel 3. The effective memory that is available to the system is only half of what is installed.

Table 20. DIMM population sequence for mirrored-channel mode

Number of installed DIMMs	1 processor installed
	DIMM connector
2	3, 5
3	1, 3, 5
4	3, 5, 8, 10
6	3, 5, 8, 10, <b>1, 12</b>
8	3, 5, 8, 10, <b>4, 6, 7, 9</b>
9	3, 5, 8, 10, <b>1, 2, 4, 6, 12</b>
12	3, 5, 8, 10, 4, 6, 7, 9, 1, 12, <b>2, 11</b>

**Note:** For mirrored-channel mode, the DIMM pair must be identical in size, type, and rank count.

Table 21. DIMM population sequence for mirrored-channel mode

Number of installed DIMMs	2 processors installed
	DIMM connector
4	3, 5, 22, 20
5	3, 5, 22, 20, 1
6	3, 5, 22, 20, 1, 24
7	3, 5, 22, 20, 8, 10, 24
8	3, 5, 22, 20, 8, 10, 17, 15
9	3, 5, 22, 20, 1, 8, 10, 12, 24
10	3, 5, 8, 10, 22, 20, 17, 15, 1, 12
12	3, 5, 8, 10, 22, 20, 17, 15, 1, 12, 24, 13
13	3, 5, 8, 10, 22, 20, 17, 15, 1, 12, 2, 4, 6
14	3, 5, 8, 10, 22, 20, 17, 15, 1, 12, 21, 19, 18, 16
15	3, 5, 8, 10, 22, 20, 17, 15, 1, 12, 2, 4, 6, 24, 13
16	3, 5, 8, 10, 22, 20, 17, 15, 21, 19, 18, 16, 4, 6, 7, 9
17	3, 4, 5, 6, 8, 10, 22, 21, 20, 19, 18, 17, 16, 15, 1, 2, 12
18	3, 4, 5, 6, 7, 8, 9, 10, 22, 20, 17, 15, 1, 2, 11, 12, 24, 13
20	1, 2, 3, 4, 5, 6, 7, 8, 9, 10, 11, 12, 22, 20, 17, 15, 21, 19, 18, 16
21	1, 2, 3, 4, 5, 6, 7, 8, 9, 10, 11, 12, 22, 21, 20, 19, 17, 15, 24, 14, 13
24	1, 2, 3, 4, 5, 6, 7, 8, 9, 10, 11, 12, 22, 21, 20, 19, 18, 17, 16, 15, 24, 23, 14, 13

**Note:** For mirrored-channel mode, the DIMM pair must be identical in size, type, and rank count.

## Memory rank sparing

In rank-sparing mode, one memory DIMM rank serves as a spare of the other ranks on the same channel. The spare rank is held in reserve and is not used as active memory. The spare rank must have identical or larger memory capacity than all the other active DIMM ranks on the same channel. After an error threshold is surpassed, the contents of that rank is copied to the spare rank. The failed rank of DIMMs is taken offline, and the spare rank is put online and used as active memory in place of the failed rank.

Table 22. DIMM population sequence for rank-sparing mode

Number of installed processors	Number of installed DIMMs	DIMM connector
1	2	5, 6
	4	5, 6, 7, 8
	6	5, 6, 7, 8, 3, 4
	8	5, 6, 7, 8, 3, 4, 9, 10
	10	5, 6, 7, 8, 3, 4, 9, 10, 1, 2
	12	5, 6, 7, 8, 3, 4, 9, 10, 1, 2, 11, 12
2	4	5, 6, 20, 19

Table 22. DIMM population sequence for rank-sparing mode (continued)

Number of installed processors	Number of installed DIMMs	DIMM connector
	6	5, 6, 20, 19, <b>7, 8</b>
	8	5, 6, 20, 19, 7, 8, <b>18, 17</b>
	10	5, 6, 20, 19, 7, 8, 18, 17, <b>3, 4</b>
	12	5, 6, 20, 19, 7, 8, 18, 17, 3, 4, <b>22, 21</b>
	14	5, 6, 20, 19, 7, 8, 18, 17, 3, 4, 22, 21, <b>9, 10</b>
	16	5, 6, 20, 19, 7, 8, 18, 17, 3, 4, 22, 21, 9, 10, <b>16, 15</b>
	18	5, 6, 20, 19, 7, 8, 18, 17, 3, 4, 22, 21, 9, 10, 16, 15, <b>1, 2</b>
	20	5, 6, 20, 19, 7, 8, 18, 17, 3, 4, 22, 21, 9, 10, 16, 15, 1, 2, <b>24, 23</b>
	22	5, 6, 20, 19, 7, 8, 18, 17, 3, 4, 22, 21, 9, 10, 16, 15, 1, 2, 24, 23, <b>11, 12</b>
	24	5, 6, 20, 19, 7, 8, 18, 17, 3, 4, 22, 21, 9, 10, 16, 15, 1, 2, 24, 23, 11, 12, <b>14, 13</b>

## RAID configuration

Using a Redundant Array of Independent Disks (RAID) to store data remains one of the most common and cost-efficient methods to increase server's storage performance, availability, and capacity.

RAID increases performance by allowing multiple drives to process I/O requests simultaneously. RAID can also prevent data loss in case of a drive failure by reconstructing (or rebuilding) the missing data from the failed drive using the data from the remaining drives.

RAID array (also known as RAID drive group) is a group of multiple physical drives that uses a certain common method to distribute data across the drives. A virtual drive (also known as virtual disk or logical drive) is a partition in the drive group that is made up of contiguous data segments on the drives. Virtual drive is presented up to the host operating system as a physical disk that can be partitioned to create OS logical drives or volumes.

An introduction to RAID is available at the following Lenovo Press website:

<https://lenovopress.com/lp0578-lenovo-raid-introduction>

Detailed information about RAID management tools and resources is available at the following Lenovo Press website:

<https://lenovopress.com/lp0579-lenovo-raid-management-tools-and-resources>

---

## Install the operating system

Several options are available to install an operating system on the server.

- **Lenovo XClarity Administrator**

If you are managing your server using Lenovo XClarity Administrator, you can use it to deploy operating-system images to up to 28 managed servers concurrently. For more information about using Lenovo XClarity Administrator to deploy operating system images, see:

[http://sysmgt.lenovofiles.com/help/topic/com.lenovo.lxca.doc/compute\\_node\\_image\\_deployment.html](http://sysmgt.lenovofiles.com/help/topic/com.lenovo.lxca.doc/compute_node_image_deployment.html)

- **Lenovo XClarity Provisioning Manager**

Lenovo XClarity Provisioning Manager is used to install operating system of single server. You can complete operating system installation by following the instructions in Lenovo XClarity Provisioning Manager OS Installation function.

- **Install the operating system manually**

If you cannot install the operating system through Lenovo XClarity Administrator or Lenovo XClarity Provisioning Manager, you can install the operating system manually. For more information about installing a specific operating system:

1. Go to <http://datacentersupport.lenovo.com> and navigate to the support page for your server.
2. Click **How-tos & Solutions**.
3. Select an operating system and the installation instructions will be displayed.

---

## Back up the compute node configuration

After setting up the compute node or making changes to the configuration, it is a good practice to make a complete backup of the compute node configuration.

Make sure that you create backups for the following compute node components:

- **Management processor**

You can back up the management processor configuration through the Lenovo XClarity Controller interface. For details about backing up the management processor configuration, see:

[http://sysmgt.lenovofiles.com/help/topic/com.lenovo.systems.management.xcc.doc/NN1ia\\_c\\_backupthexcc.html](http://sysmgt.lenovofiles.com/help/topic/com.lenovo.systems.management.xcc.doc/NN1ia_c_backupthexcc.html)

Alternatively, you can use the **save** command from Lenovo XClarity Essentials OneCLI to create a backup of all configuration settings. For more information about the **save** command, see:

[http://sysmgt.lenovofiles.com/help/topic/toolsctr\\_cli\\_lenovo/onecli\\_r\\_save\\_command.html](http://sysmgt.lenovofiles.com/help/topic/toolsctr_cli_lenovo/onecli_r_save_command.html)

- **Operating system**

Use your own operating-system and user-data backup methods to back up the operating system and user data for the compute node.

---

## Chapter 5. Resolving installation issues

Use this information to resolve issues that you might have when setting up your system.

Use the information in this section to diagnose and resolve problems that you might encounter during the initial installation and setup of your server.

- “Single compute node does not power on” on page 69
- “The compute node immediately displays the POST Event Viewer when it is turned on” on page 69
- “Compute node cannot recognize a hard disk drive” on page 70
- “Displayed system memory less than installed physical memory” on page 70
- “A Lenovo optional device that was just installed does not work.” on page 71
- “Voltage planar fault is displayed in the event log” on page 71

### Single compute node does not power on

Complete the following steps until the problem is resolved:

1. If you recently installed, moved, or serviced the compute node, reseal the compute node in the bay. If the compute node was not recently installed, moved, or serviced, perform a virtual reseal through the CMM **service** command. For more information about the CMM **service** command, see the "Flex System Chassis Management Module: Command-Line Interface Reference Guide" at [http://flexsystem.lenovofiles.com/help/topic/com.lenovo.acc.cmm.doc/cli\\_command\\_service.html](http://flexsystem.lenovofiles.com/help/topic/com.lenovo.acc.cmm.doc/cli_command_service.html).
2. Check the event log on the CMM for any events that are related to the compute node and solve them.
3. Make sure that the CMM can recognize the compute node. Log in to the CMM user interface and verify that the compute node appears in the chassis view. If the CMM cannot recognize the compute node, remove it, and inspect the compute node and the back of the node bay to make sure that there is no physical damage to the connectors.
4. Make sure that the power policy that is implemented on the CMM is sufficient to enable the compute node to power on. You can view the power policy using the CMM **pmpolicy** command or the CMM web interface.
  - For more information about the CMM **pmpolicy** command, see the "Flex System Chassis Management Module: Command-Line Interface Reference Guide" at [http://flexsystem.lenovofiles.com/help/topic/com.lenovo.acc.cmm.doc/cli\\_command\\_pmpolicy.html](http://flexsystem.lenovofiles.com/help/topic/com.lenovo.acc.cmm.doc/cli_command_pmpolicy.html).
  - From the CMM web interface, select **Power Modules and Management** from the Chassis Management menu. For more information, see the "Flex System Chassis Management Module: User's Guide" at [http://flexsystem.lenovofiles.com/help/topic/com.lenovo.acc.cmm.doc/cmm\\_user\\_guide.html](http://flexsystem.lenovofiles.com/help/topic/com.lenovo.acc.cmm.doc/cmm_user_guide.html). All fields and options are described in the CMM web interface online help.
5. Replace the system-board assembly (see the *Lenovo ThinkSystem SN550 Type 7X16 Maintenance Manual* for more information).

**Note:** Until you are able to replace the system-board assembly, you can attempt to power on the compute node from the CMM.

### The compute node immediately displays the POST Event Viewer when it is turned on

Complete the following steps until the problem is solved.

1. Correct any errors that are indicated by the light path diagnostics LEDs.
2. Make sure that the compute node supports all the processors and that the processors match in speed and cache size.

You can view processor details from system setup.

To determine if the processor is supported for the compute node, see <http://www.lenovo.com/serverproven/>.

3. (Trained technician only) Make sure that processor 1 is seated correctly
4. (Trained technician only) Remove processor 2 and restart the compute node.
5. Replace the following components one at a time, in the order shown, restarting the compute node each time:
  - a. (Trained technician only) Processor
  - b. (Trained technician only) System board

### Compute node cannot recognize a hard disk drive

Complete the following steps until the problem is solved.

1. Verify that the drive is supported for the compute node. See <http://www.lenovo.com/serverproven/> for a list of supported hard drives.
2. Make sure that the drive is seated in the drive bay properly and that there is no physical damage to the drive connectors.
3. Run the diagnostics tests for the hard disk drives. When you start a compute node and press F1, the Lenovo XClarity Provisioning Manager interface is displayed by default. You can perform hard drive diagnostics from this interface. From the Diagnostic page, click **Run Diagnostic → HDD test**.

Based on those tests:

- a. If the drive fails the diagnostic test, replace the drive.
- b. If the drive passes the diagnostic tests but is still not recognized, complete the following steps:
  - 1) Replace the drive.
  - 2) Replace the hard drive backplane (see “Remove the 2.5-inch drive backplane” on page 31)).
  - 3) Replace the system-board assembly (see *ThinkSystem SN550 Type 7X16 Maintenance Manual* for more information).

### Displayed system memory less than installed physical memory

Complete the following steps until the problem is solved.

1. Make sure that:
  - a. You have installed the correct type of memory (see “Specifications” on page 5).
  - b. Memory mirroring or memory sparing mode does not account for the discrepancy.  
To determine the status of a DIMM, restart the compute node and press F1 to display the Lenovo XClarity Provisioning Manager interface. Then, click **System settings → Memory**.
2. If new memory has recently been installed, make sure that no configuration events are reported in the event log. If there are any events, resolve them.

**Note:** DIMMs are verified as authentic Lenovo or IBM modules by the UEFI software. If any non-authentic DIMMs are detected, an informational message appears in the system event log and memory performance might be limited. Non-authentic DIMMs are not covered by your Lenovo warranty.

3. If the compute node was recently installed, moved, or serviced, make sure that the DIMMs are correctly seated in the connectors (see “Install a DIMM” on page 35).
4. Make sure that all DIMMs are enabled. The compute node might have automatically disabled a DIMM when it detected a problem, or a DIMM might have been manually disabled.

To determine the status of a DIMM, restart the compute node and press F1 to display the Lenovo XClarity Provisioning Manager interface. Then, click **System settings → Memory**.

5. Run memory diagnostics. When you start a compute node and press F1, the Lenovo XClarity Provisioning Manager interface is displayed by default. You can perform memory diagnostics from this interface. From the Diagnostic page, click **Run Diagnostic → Memory test**.
6. Remove DIMMs until the compute node is showing the correct amount of memory. Install one DIMM at a time until you can determine which DIMM is not working properly. Remove that DIMM and replace it with a good DIMM.

**Note:** After you install or remove a DIMM, you must change and save the new configuration information by using the Setup utility. When you turn on the compute node, a message indicates that the memory configuration has changed. Press F1 to display the Lenovo XClarity Provisioning Manager interface. Then, save the configuration.

7. If the problem remains, contact Lenovo Support.

### **A Lenovo optional device that was just installed does not work.**

1. Make sure that:
  - The device is supported for the compute node (see <http://www.lenovo.com/serverproven/>).
  - You followed the installation instructions that came with the device and the device is installed correctly.
  - You have not loosened any other installed devices or cables.
  - You updated the configuration information in the Setup utility. Whenever memory or any other device is changed, you must update the configuration.
2. Reseat the device that you just installed.
3. Replace the device that you just installed.

### **Voltage planar fault is displayed in the event log**

Complete the following steps until the problem is solved.

1. Revert the system to the minimum configuration. See “Specifications” on page 5 for the minimally required number of processors and DIMMs.
2. Restart the system.
  - If the system restarts, add each of the items that you removed one at a time, restarting the system each time, until the error occurs. Replace the item for which the error occurs.
  - If the system does not restart, suspect the system board.





---

## Appendix A. Getting help and technical assistance

If you need help, service, or technical assistance or just want more information about Lenovo products, you will find a wide variety of sources available from Lenovo to assist you.

On the World Wide Web, up-to-date information about Lenovo systems, optional devices, services, and support are available at:

<http://datacentersupport.lenovo.com>

**Note:** This section includes references to IBM web sites and information about obtaining service. IBM is Lenovo's preferred service provider for ThinkSystem.

---

### Before you call

Before you call, there are several steps that you can take to try and solve the problem yourself. If you decide that you do need to call for assistance, gather the information that will be needed by the service technician to more quickly resolve your problem.

#### Attempt to resolve the problem yourself

You can solve many problems without outside assistance by following the troubleshooting procedures that Lenovo provides in the online help or in the Lenovo product documentation. The Lenovo product documentation also describes the diagnostic tests that you can perform. The documentation for most systems, operating systems, and programs contains troubleshooting procedures and explanations of error messages and error codes. If you suspect a software problem, see the documentation for the operating system or program.

You can find the product documentation for your ThinkSystem products at the following location:

<http://thinksystem.lenovofiles.com/help/index.jsp>

You can take these steps to try to solve the problem yourself:

- Check all cables to make sure that they are connected.
- Check the power switches to make sure that the system and any optional devices are turned on.
- Check for updated software, firmware, and operating-system device drivers for your Lenovo product. The Lenovo Warranty terms and conditions state that you, the owner of the Lenovo product, are responsible for maintaining and updating all software and firmware for the product (unless it is covered by an additional maintenance contract). Your service technician will request that you upgrade your software and firmware if the problem has a documented solution within a software upgrade.
- If you have installed new hardware or software in your environment, check <http://www.lenovo.com/serverproven/> to make sure that the hardware and software is supported by your product.
- Go to <http://datacentersupport.lenovo.com> and check for information to help you solve the problem.
  - Check the Lenovo forums at [https://forums.lenovo.com/t5/Datacenter-Systems/ct-p/sv\\_eg](https://forums.lenovo.com/t5/Datacenter-Systems/ct-p/sv_eg) to see if someone else has encountered a similar problem.

You can solve many problems without outside assistance by following the troubleshooting procedures that Lenovo provides in the online help or in the Lenovo product documentation. The Lenovo product documentation also describes the diagnostic tests that you can perform. The documentation for most systems, operating systems, and programs contains troubleshooting procedures and explanations of error

messages and error codes. If you suspect a software problem, see the documentation for the operating system or program.

### **Gathering information needed to call Support**

If you believe that you require warranty service for your Lenovo product, the service technicians will be able to assist you more efficiently if you prepare before you call. You can also see <http://datacentersupport.lenovo.com/warrantylookup> for more information about your product warranty.

Gather the following information to provide to the service technician. This data will help the service technician quickly provide a solution to your problem and ensure that you receive the level of service for which you might have contracted.

- Hardware and Software Maintenance agreement contract numbers, if applicable
- Machine type number (Lenovo 4-digit machine identifier)
- Model number
- Serial number
- Current system UEFI and firmware levels
- Other pertinent information such as error messages and logs

As an alternative to calling Lenovo Support, you can go to <https://www-947.ibm.com/support/servicerequest/Home.action> to submit an Electronic Service Request. Submitting an Electronic Service Request will start the process of determining a solution to your problem by making the pertinent information available to the service technicians. The Lenovo service technicians can start working on your solution as soon as you have completed and submitted an Electronic Service Request.

---

## **Collecting service data**

To clearly identify the root cause of a server issue or at the request of Lenovo Support, you might need collect service data that can be used for further analysis. Service data includes information such as event logs and hardware inventory.

Service data can be collected through the following tools:

- **Lenovo XClarity Provisioning Manager**

Use the Collect Service Data function of Lenovo XClarity Provisioning Manager to collect system service data. You can collect existing system log data or run a new diagnostic to collect new data.

- **Lenovo XClarity Controller**

You can use the Lenovo XClarity Controller web interface or the CLI to collect service data for the server. The file can be saved and sent to Lenovo Support.

- For more information about using the web interface to collect service data, see [http://sysmgt.lenovofiles.com/help/topic/com.lenovo.systems.management.xcc.doc/NN1ia\\_c\\_servicesandsupport.html](http://sysmgt.lenovofiles.com/help/topic/com.lenovo.systems.management.xcc.doc/NN1ia_c_servicesandsupport.html).
- For more information about using the CLI to collect service data, see [http://sysmgt.lenovofiles.com/help/topic/com.lenovo.systems.management.xcc.doc/nn1ia\\_r\\_ffdcommand.html](http://sysmgt.lenovofiles.com/help/topic/com.lenovo.systems.management.xcc.doc/nn1ia_r_ffdcommand.html).

- **Chassis Management Module (CMM)**

Use the Download Service Data function of the CMM to collect service data for compute nodes.

For more information about downloading service data from the CMM, see [http://flexsystem.lenovofiles.com/help/topic/com.lenovo.acc.cmm.doc/cmm\\_ui\\_service\\_and\\_support.html](http://flexsystem.lenovofiles.com/help/topic/com.lenovo.acc.cmm.doc/cmm_ui_service_and_support.html).

- **Lenovo XClarity Administrator**

Lenovo XClarity Administrator can be set up to collect and send diagnostic files automatically to Lenovo Support when certain serviceable events occur in Lenovo XClarity Administrator and the managed endpoints. You can choose to send diagnostic files to Lenovo Support using Call Home or to another service provider using SFTP. You can also manually collect diagnostic files, open a problem record, and send diagnostic files to the Lenovo Support Center.

You can find more information about setting up automatic problem notification within the Lenovo XClarity Administrator at [http://sysmgt.lenovofiles.com/help/topic/com.lenovo.lxca.doc/admin\\_setupcallhome.html](http://sysmgt.lenovofiles.com/help/topic/com.lenovo.lxca.doc/admin_setupcallhome.html).

- **Lenovo XClarity Essentials OneCLI**

Lenovo XClarity Essentials OneCLI has inventory application to collect service data. It can run both in-band and out-of-band. When running in-band within the host operating system on the server, OneCLI can collect information about the operating system, such as the operating system event log, in addition to the hardware service data.

To obtain service data, you can run the **getinfor** command. For more information about running the **getinfor**, see [http://sysmgt.lenovofiles.com/help/topic/toolsctr\\_cli\\_lenovo/onecli\\_r\\_getinfor\\_command.html](http://sysmgt.lenovofiles.com/help/topic/toolsctr_cli_lenovo/onecli_r_getinfor_command.html).

---

## Contacting Support

You can contact Support to obtain help for your issue.

You can receive hardware service through a Lenovo Authorized Service Provider. To locate a service provider authorized by Lenovo to provide warranty service, go to <https://datacentersupport.lenovo.com/us/en/serviceprovider> and use filter searching for different countries. For Lenovo support telephone numbers, see <https://datacentersupport.lenovo.com/us/en/supportphonenumberlist>. In the U.S. and Canada, call 1-800-426-7378.

In the U.S. and Canada, hardware service and support is available 24 hours a day, 7 days a week. In the U.K., these services are available Monday through Friday, from 9 a.m. to 6 p.m.

### China product support

To contact product support in China, go to:  
<http://support.lenovo.com.cn/lenovo/wsi/es/ThinkSystem.html>

You can also call 400-106-8888 for product support. The call support is available Monday through Friday, from 9 a.m. to 6 p.m.

### Taiwan product support

To contact product support for Taiwan, call 0800-016-888. The call support is available 24 hours a day, 7 days a week.



---

# Index

2.5-inch drive backplane  
installing options 33  
removing 31

## A

activity LED 15  
air baffle  
removing 30  
replacing 52

## B

back up the compute node configuration 68  
button, power 15

## C

CMOS battery 19  
collecting service data 74  
Common installation issues 69  
components  
compute node 15  
system board 19  
compute node cover  
installing 52  
compute node in the chassis  
installing 54  
compute node setup 25  
compute node setup checklist 25  
Configuration - ThinkSystem SN550 59  
configure the firmware 62  
connectors, system-board 19  
contamination, particulate and gaseous 7  
cover  
removing 29  
CPU  
option install 47  
creating a personalized support web page 73  
custom support web page 73

## D

devices, static-sensitive  
handling 28  
DIMM  
installing options 35  
DIMM configuration 63  
DIMM connectors 19  
DIMM installation order 38  
Drive status LED 15

## F

fabric connector  
location 19  
fault LED 15  
features 3  
firmware updates 1  
flash power module  
installing 38

## G

gaseous contamination 7  
Getting help 73  
guidelines  
options installation 26  
system reliability 27

## H

handling static-sensitive devices 28  
hardware options  
installing 28  
hardware service and support telephone numbers 75  
HDD backplane connector 19  
help 73  
hot-swap drive  
installing options 34

## I

identification LED 15  
independent memory mode 64  
install the operating system 67  
installation 1  
guidelines 26  
installation guidelines 26  
installing  
compute node cover 52  
compute node in the chassis 54  
flash power module 38  
installing options  
2.5-inch drive backplane 33  
DIMM 35  
hot-swap drive 34  
I/O expansion adapter 39  
M.2 backplane 42  
M.2 driver 43  
memory module 35  
RAID adapter 49  
introduction 1  
I/O expansion adapter  
installing options 39  
I/O expansion connectors 19

## J

jumpers, system board 20

## K

KVM cable 19

## L

LEDs  
activity 15  
CMOS battery error 18  
DIMMs 18  
fault 15  
identification 15  
I/O expansion adapter 18

- microprocessor 18
- power 15
- SAS backplane 18
- system board 18
- light path diagnostics 17
- light path diagnostics panel 18

## M

- M.2 backplane
  - installing options 42
- M.2 drive
  - installing options 43
- management options 8
- memory configuration 63, 67
- memory mirroring 65
- memory module
  - installing options 35
- memory module installation order 38
- memory rank sparing 66
- microprocessor
  - option install 47
- microprocessor connector 19

## O

- online documentation 1
- option install
  - CPU 47
  - microprocessor 47
  - PHM 47
  - processor 47
  - processor-heat-sink module 47

## P

- particulate contamination 7
- parts list 22
- PHM
  - option install 47
- power button 15
- power LED 15
- power off the server 56
- power on the server 55
- powering off the compute node 56
- powering on the compute node 55
- processor
  - option install 47
- processor-heat-sink module
  - option install 47

## R

- RAID adapter
  - installing options 49
  - removing 32
- removing
  - 2.5-inch drive backplane 31
  - air baffle 30
  - RAID adapter 32
  - top cover 29
- replacing
  - air baffle 52
- retainer on M.2 backplane
  - adjustment 45

## S

- safety iii
- safety inspection checklist iv
- service and support
  - before you call 73
  - hardware 75
  - software 75
- service data 74
- SN550
  - introduction 1
- software service and support telephone numbers 75
- starting the compute node 55
- static-sensitive devices
  - handling 28
- stopping the compute node 56
- support web page, custom 73
- switches, system board 20
- system board
  - jumpers 20
  - layout 19
  - LEDs 18
  - switches 20
- System configuration - ThinkSystem SN550 59
- system reliability guidelines 27
- system-board
  - connectors 19

## T

- telephone numbers 75
- top cover
  - removing 29
- turning off the compute node 56
- turning on the compute node 55

## U

- update the firmware 60
- USB management button 15

## V

- validate compute node setup 56

## W

- working inside the server
  - power on 27





Part Number: SP47A10560

Printed in China

(1P) P/N: SP47A10560

