

How to fix the protective glass for X401S

PARTS LIST

Location	Description	Part No	Q'ty	Spec
GLS-1	PROTECTION GLASS X401S	—	1	909.4±1.0mm X 521±0.7mm X 4.0±0.3mm
BRK-1	X401S HOLDER GLASS A		2	
BRK-2	X401S HOLDER GLASS B		2	
CUS-1	BRACKET LED TAPE CUSHION	—	1	98mm X 8mm X 0.65mm
	CUSHION			
	DOUBLE SIDE TAPE			
CUS-2	DOUBLE SIDE TAPE CUSHION	—	2	454.2mm X 8mm X 0.8mm
	CUSHION			
	DOUBLE SIDE TAPE			
CUS-3	DOUBLE SIDE TAPE CUSHION	—	2	832.6mm X 8mm X 0.8mm
	CUSHION			
	DOUBLE SIDE TAPE			

[CUS-1] BRACKET LED TAPE CUSHION : 98 X 8 X 0.65

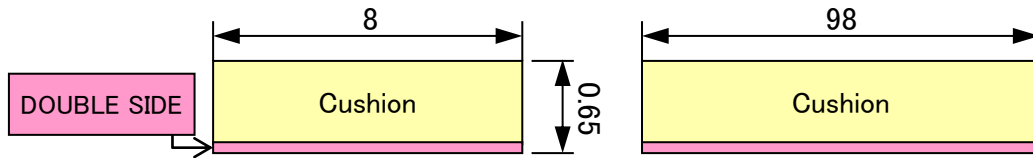

[CUS-2] DOUBLE SIDE TAPE CUSHION : 454.2 X 8 X 0.8

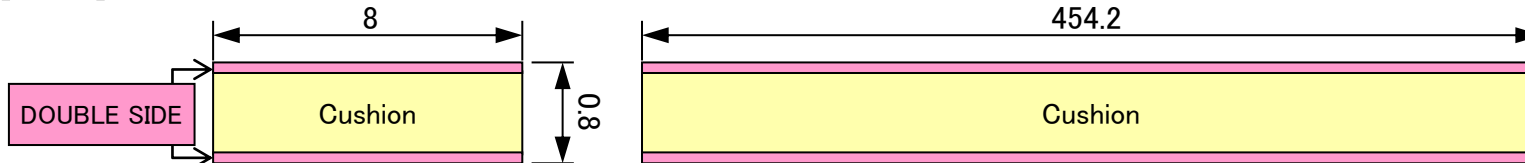

[CUS-3] DOUBLE SIDE TAPE CUSHION : 832.6 X 8 X 0.8

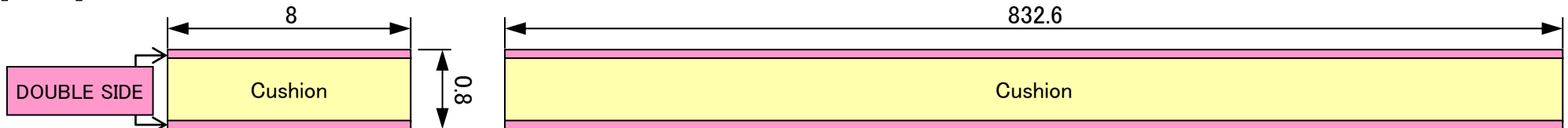

How to fix the protective glass for X401S

1. Remove BEZEL and BRACKET PWB IR.
(Amount of the screws that fix BEZEL is 8 pieces.)

Remove 8 SCREWS.

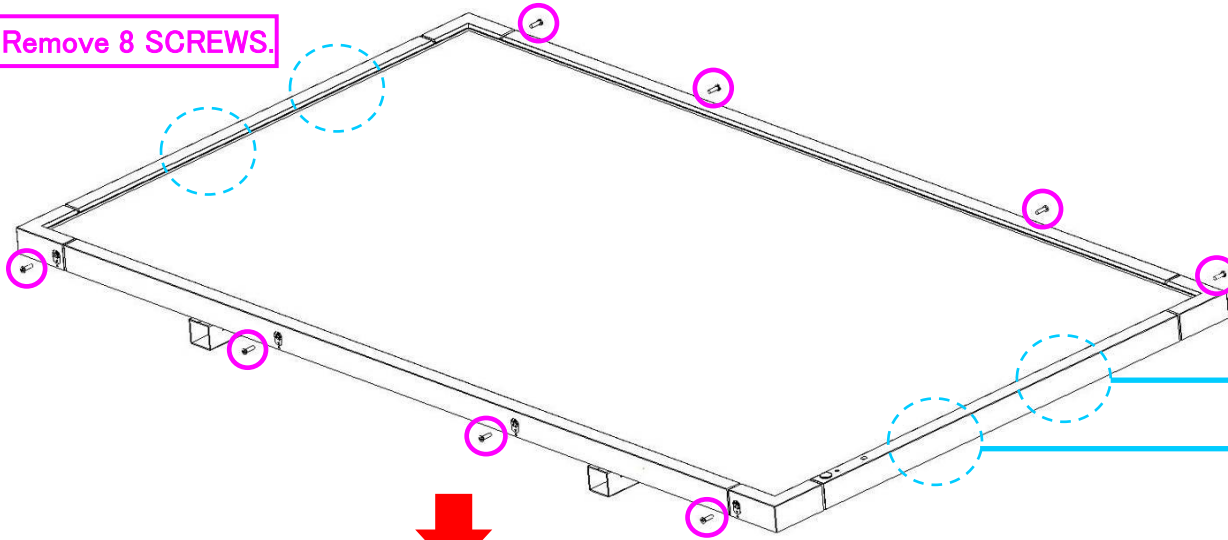

Remove the BEZEL

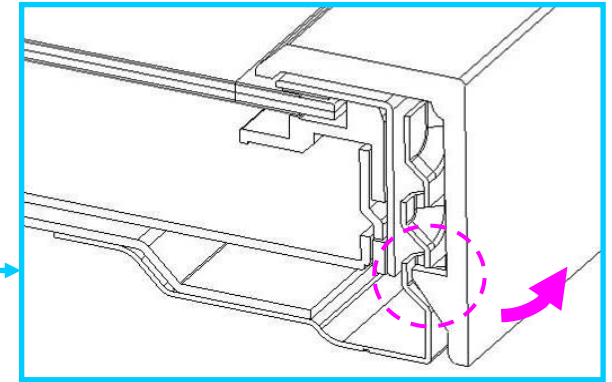
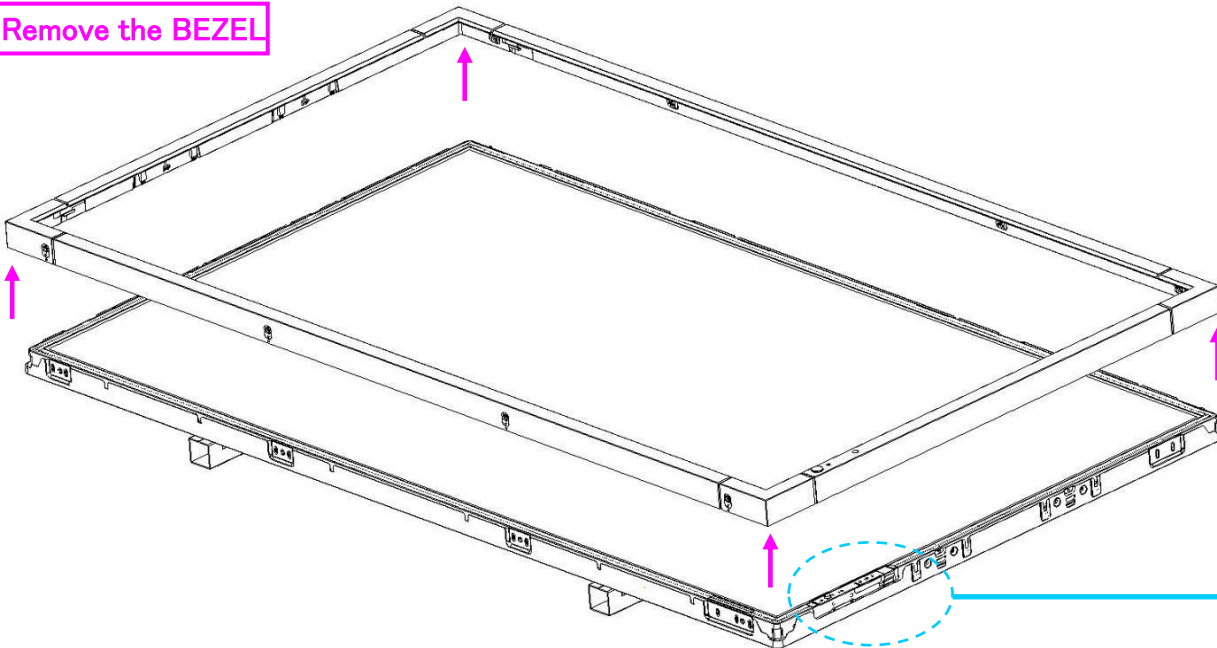

ATTENTION
Remove catching of a hook. (4 places)

REMOVE BRACKET PWB IR

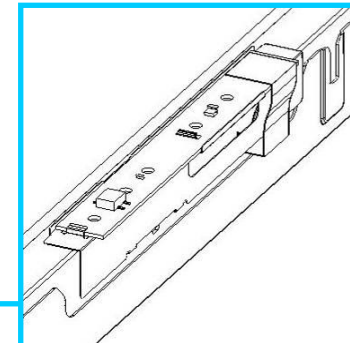

2. Paste CUS-2 and CUS-3 (DOUBLE SIDE TAPE CUSHION) and peel off separator.
Refer to SPEC of PARTS LIST for the specification of CUS-2 and CUS-3.

ATTENTION

Don't paste CUS-2 and CUS-3 on PANEL'S ACTIVE AREA.

Paste CUS-2 and CUS-3

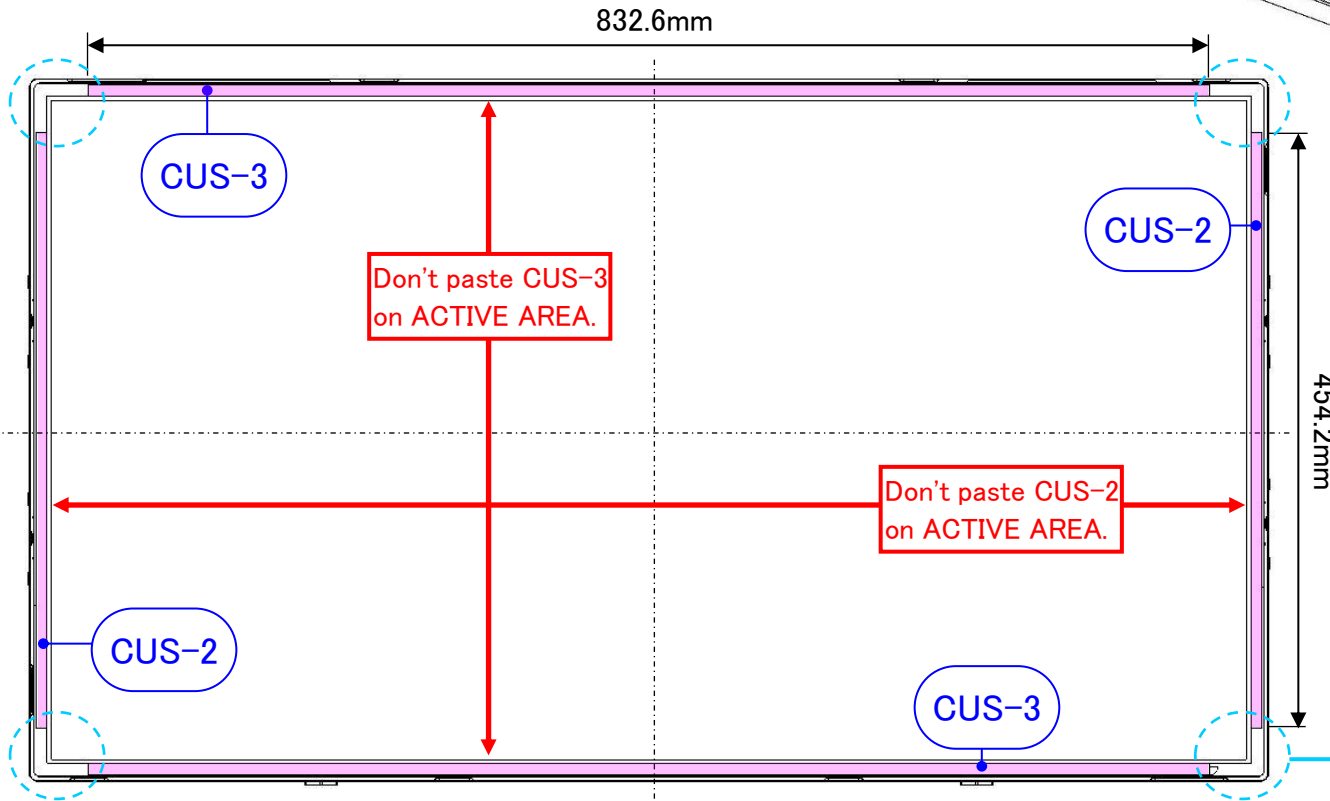
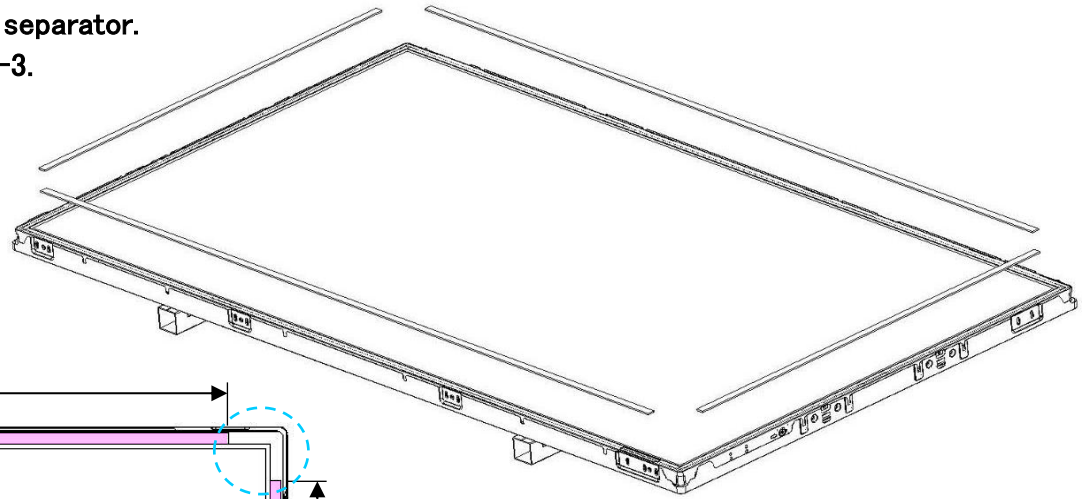

ATTENTION

Criterion which pastes CUS-2 and CUS-3 is the edge of PANEL BEZEL OPENING.

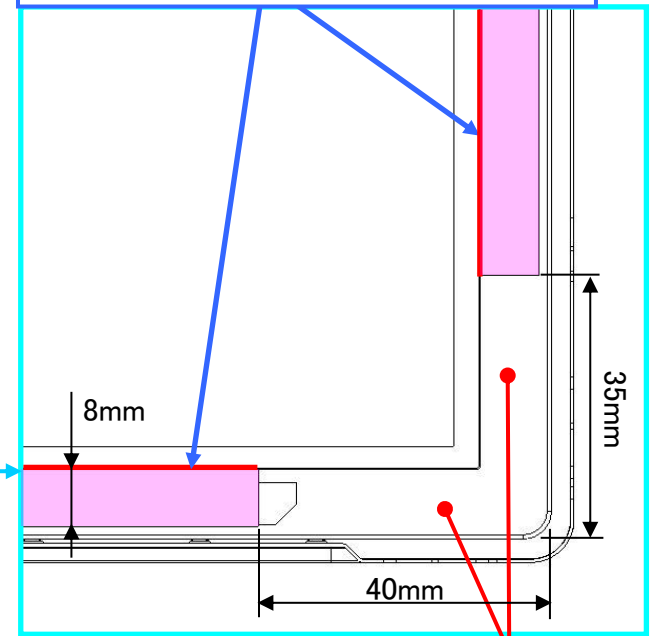

Don't paste CUS-2 and CUS-3 on these area. This note is applied for all corner.

ATTENTION
Don't use the knife to cut CUS-2 and CUS-3.
Use scissors.



3. Assemble GLS-1(PROTECTION GLASS X401S).

Before assembling, check if there's no dust or fingerprint and so on.
If find it, remove by cleaning cloth.

ATTENTION

Before assembling PROTECTION GLASS to PANEL,
remove dust from PROTECTION GLASS and PANEL-front surface.

Assemble GLS-1

Peel off separator of CUS-2 and CUS-3

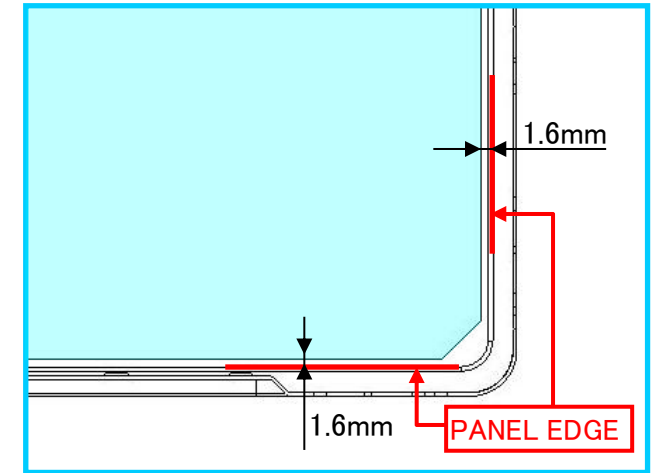
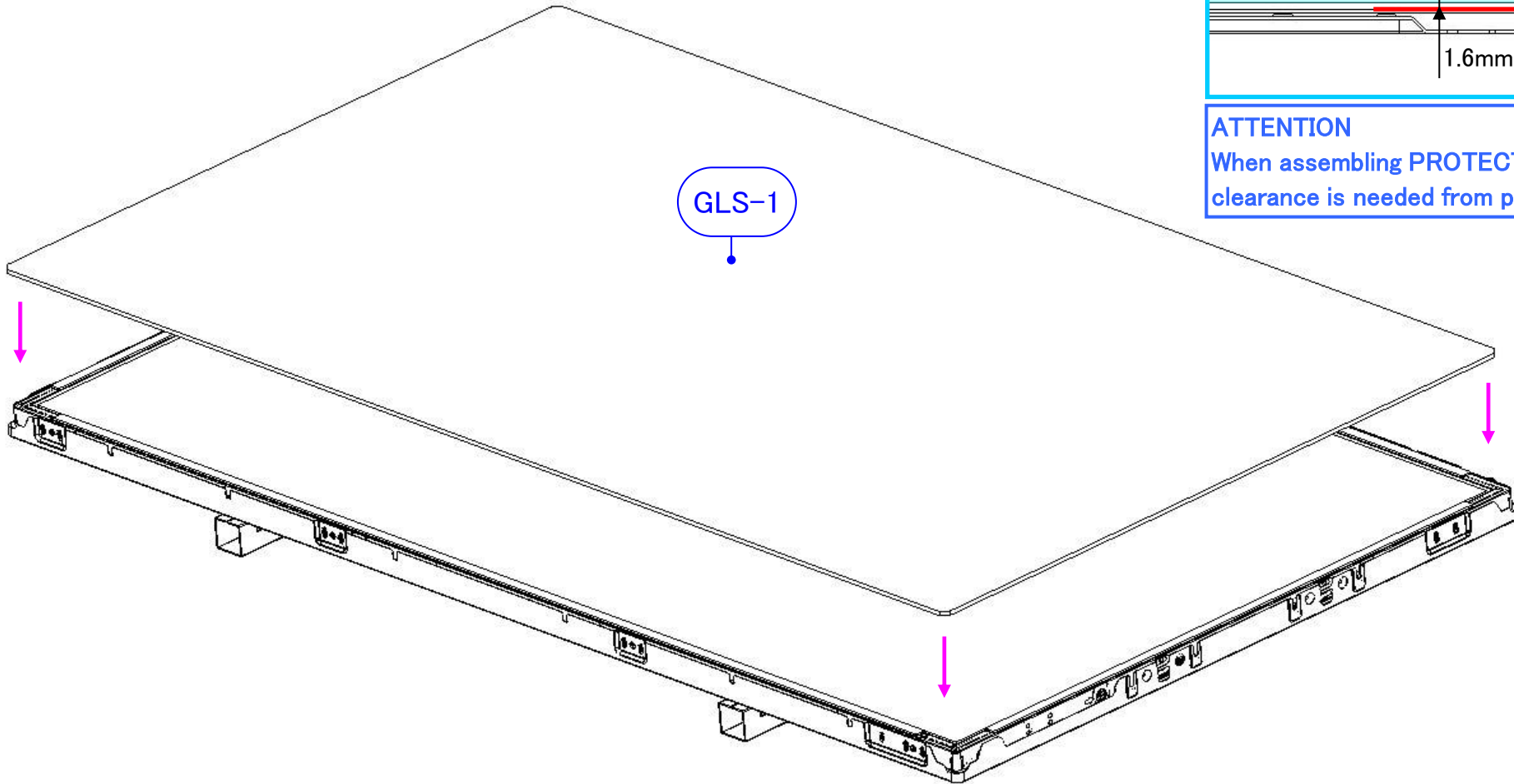

ATTENTION

When assembling PROTECTION GLASS,
clearance is needed from panel edge.

4. Assemble BRK-1 and BRK-2 (X401S HOLDER GLASS A/B).

Assemble BRK-1 and BRK-2

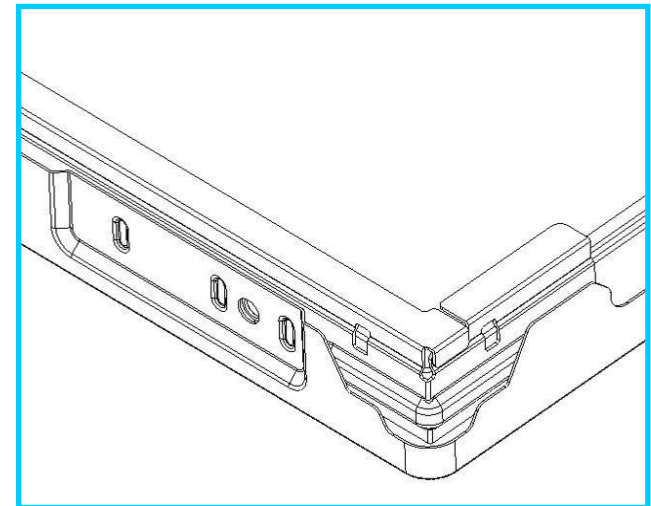
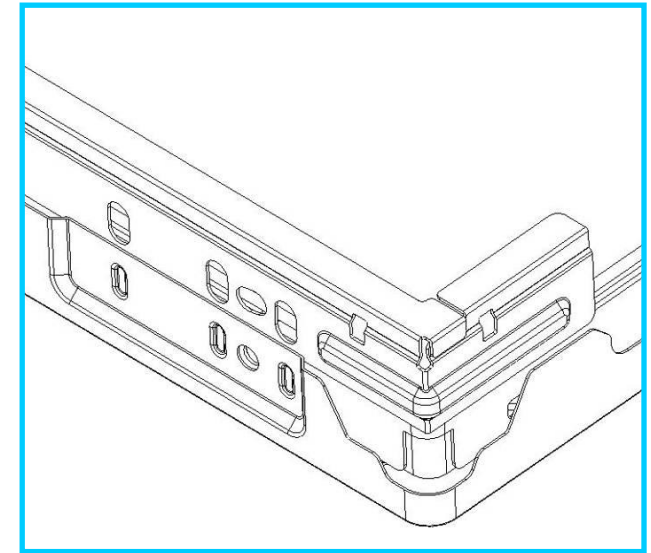
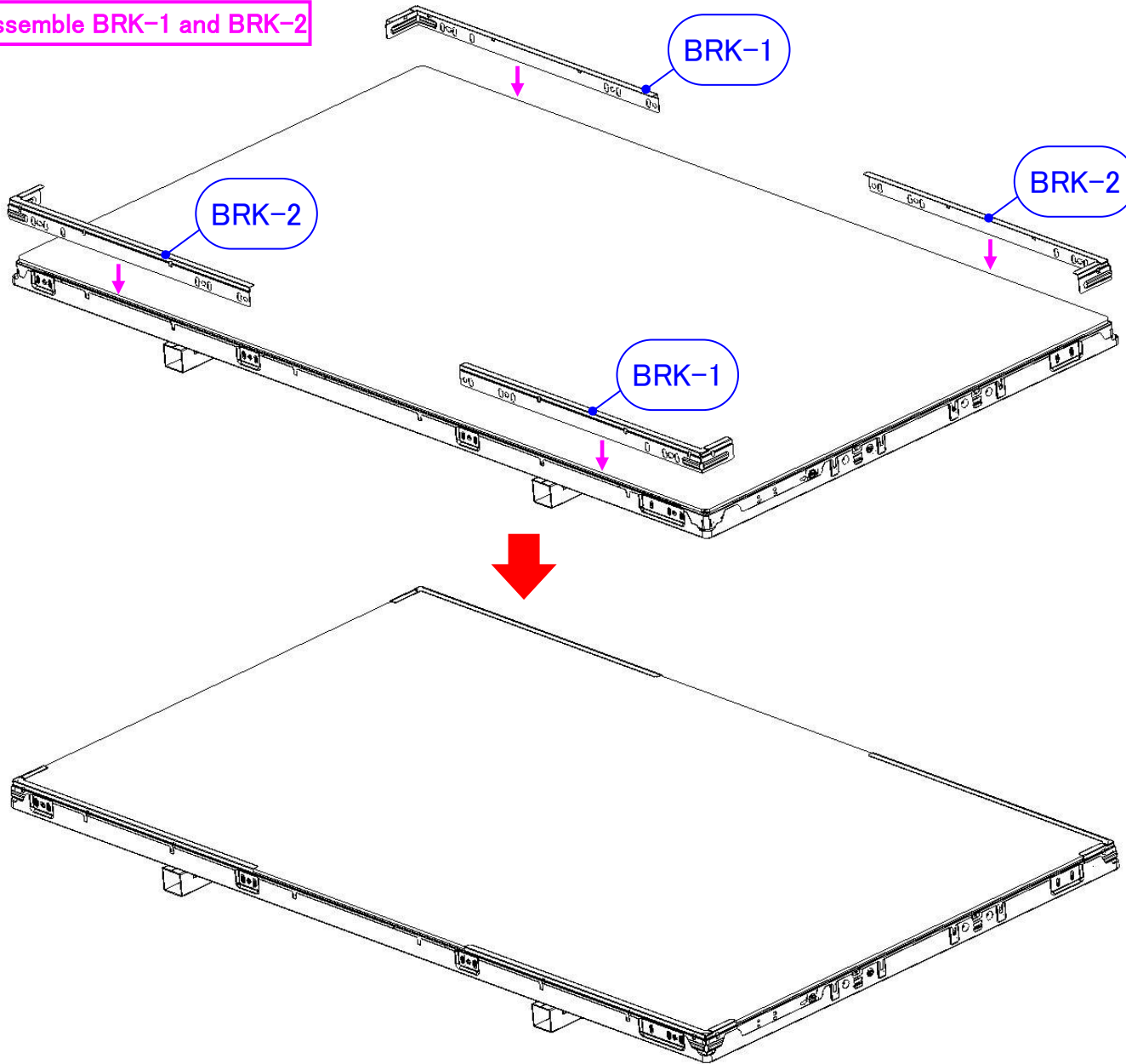

ATTENTION
Insert BRK-1 and BKT-2 between
PANEL and BACK COVER.

5. Paste CUS-1 (BRACKET LED TAPE CUSHION).
Refer to SPEC of PARTS LIST for the specification of CUS-1.
Assemble BRACKET PWB IR again.

Paste CUS-1

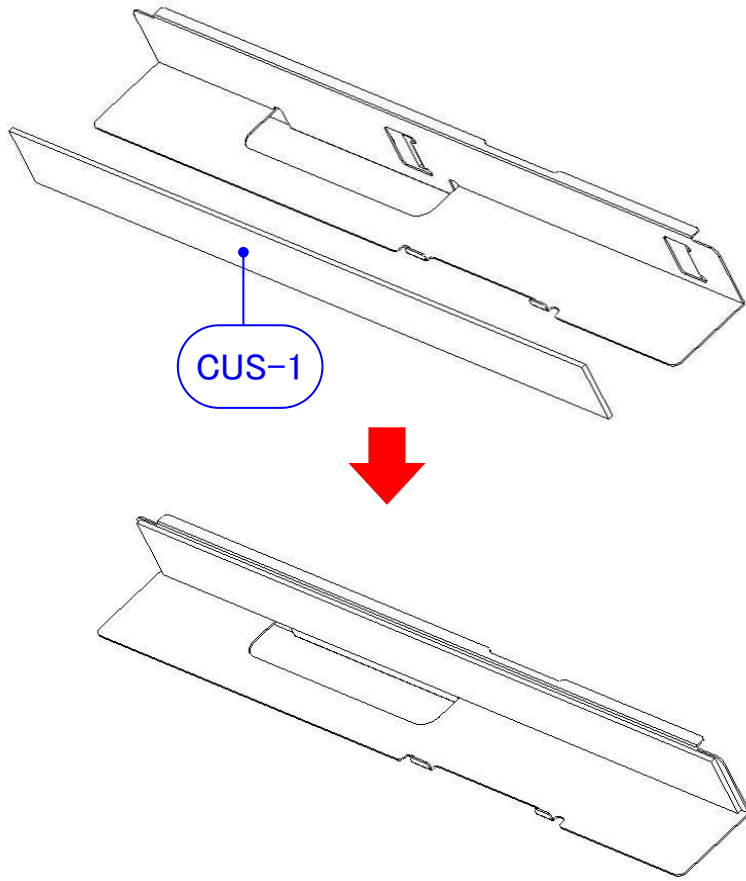

Assemble BRACKET PWB IR again.

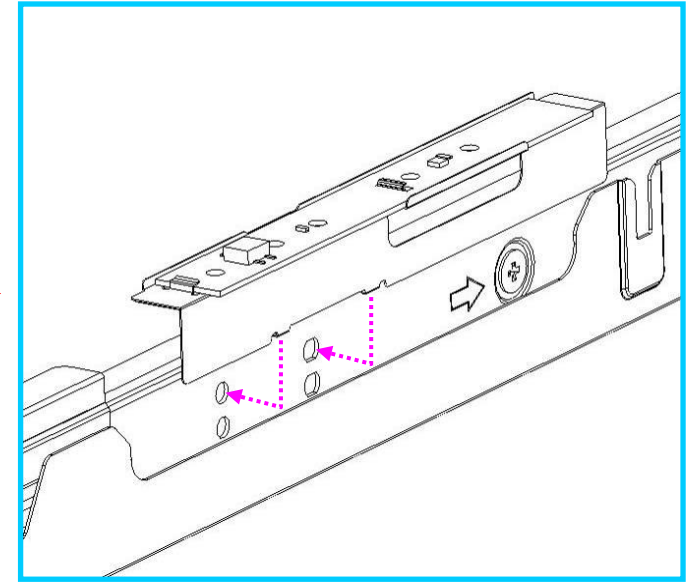

ATTENTION
Insert the positioning of
BRACKET PWB IR in the
hole of a picture.

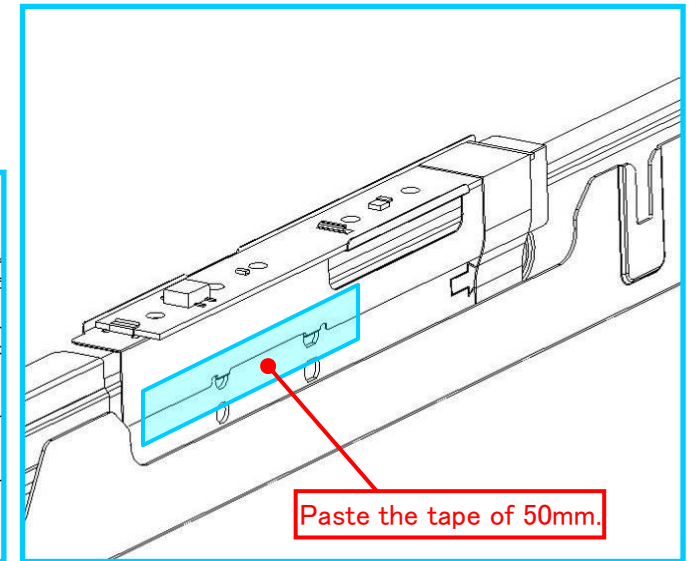
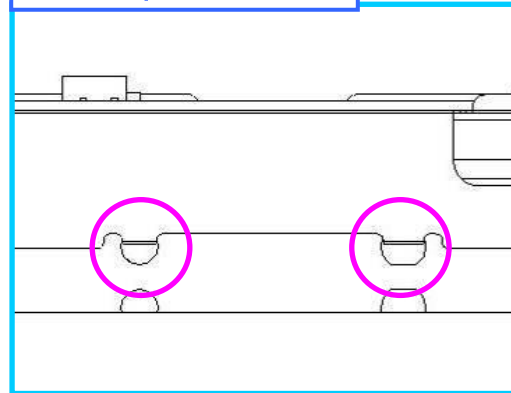

6. Rotate and install HOLE CAP.

Remove HOLE CAP

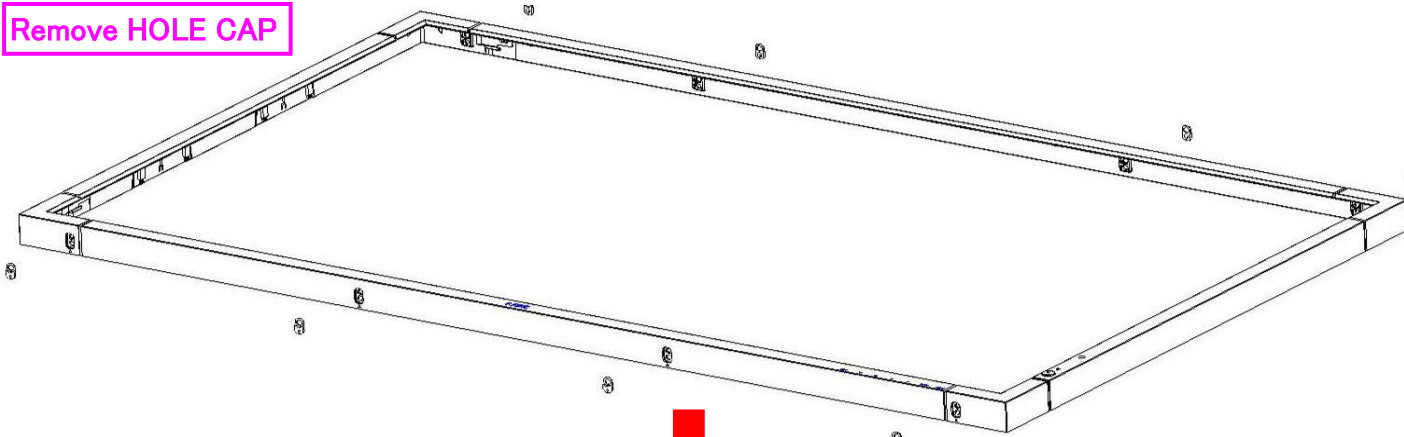

Rotate HOLE CAP

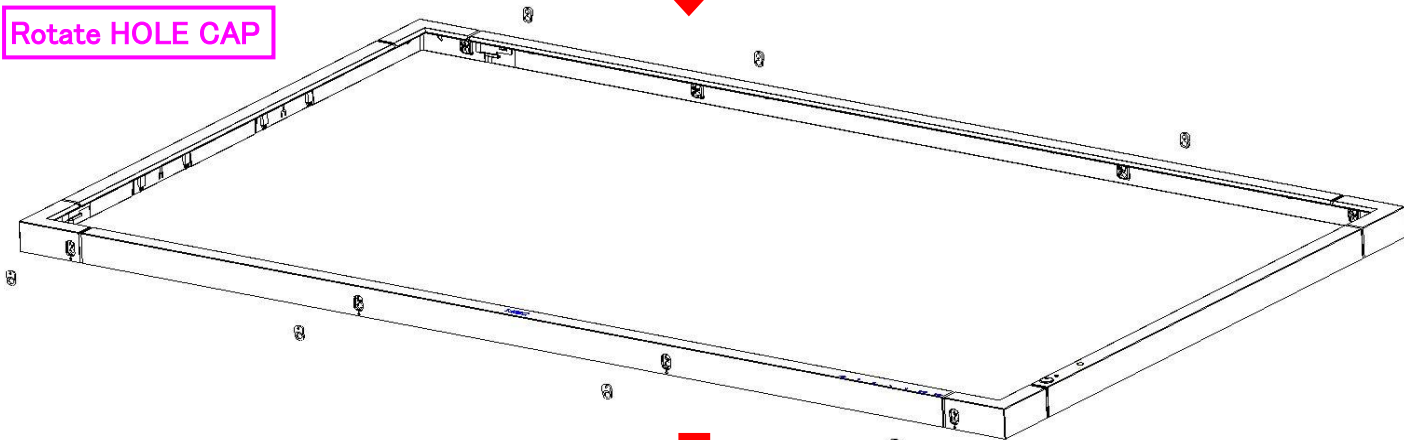

Install HOLE CAP

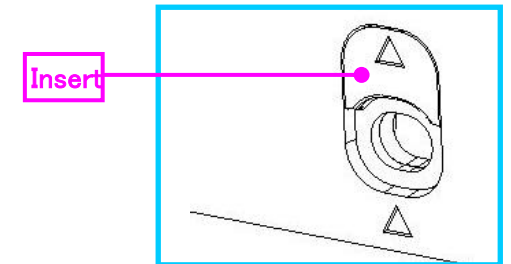
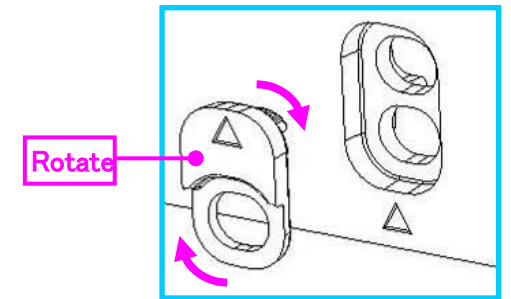
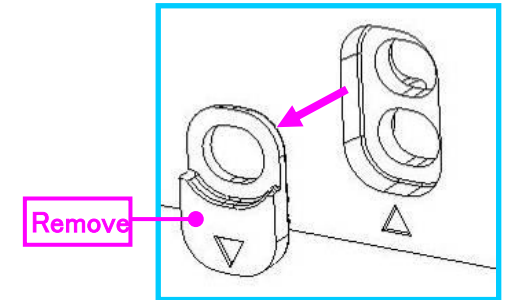
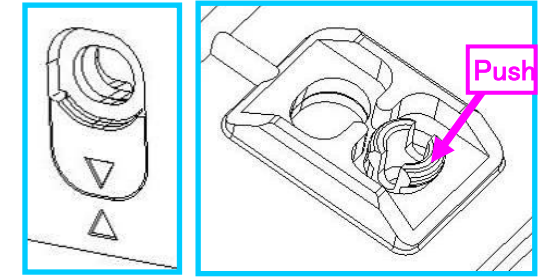
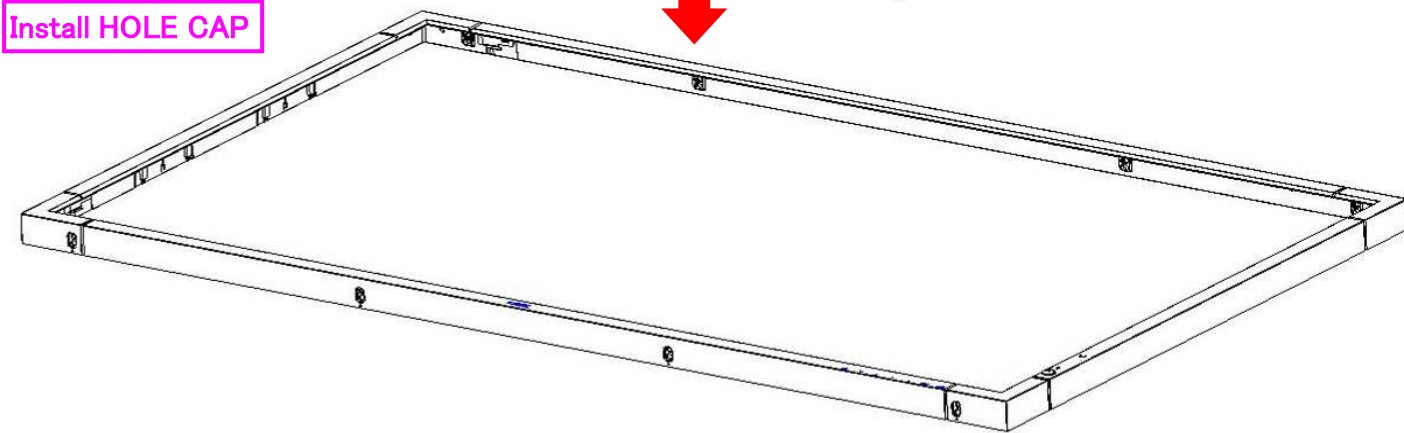

7. Assemble BEZEL again.

Assemble BEZEL again.

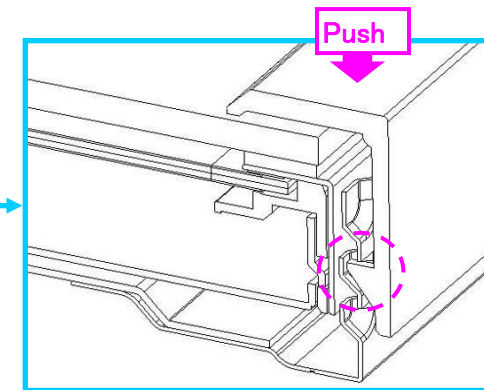
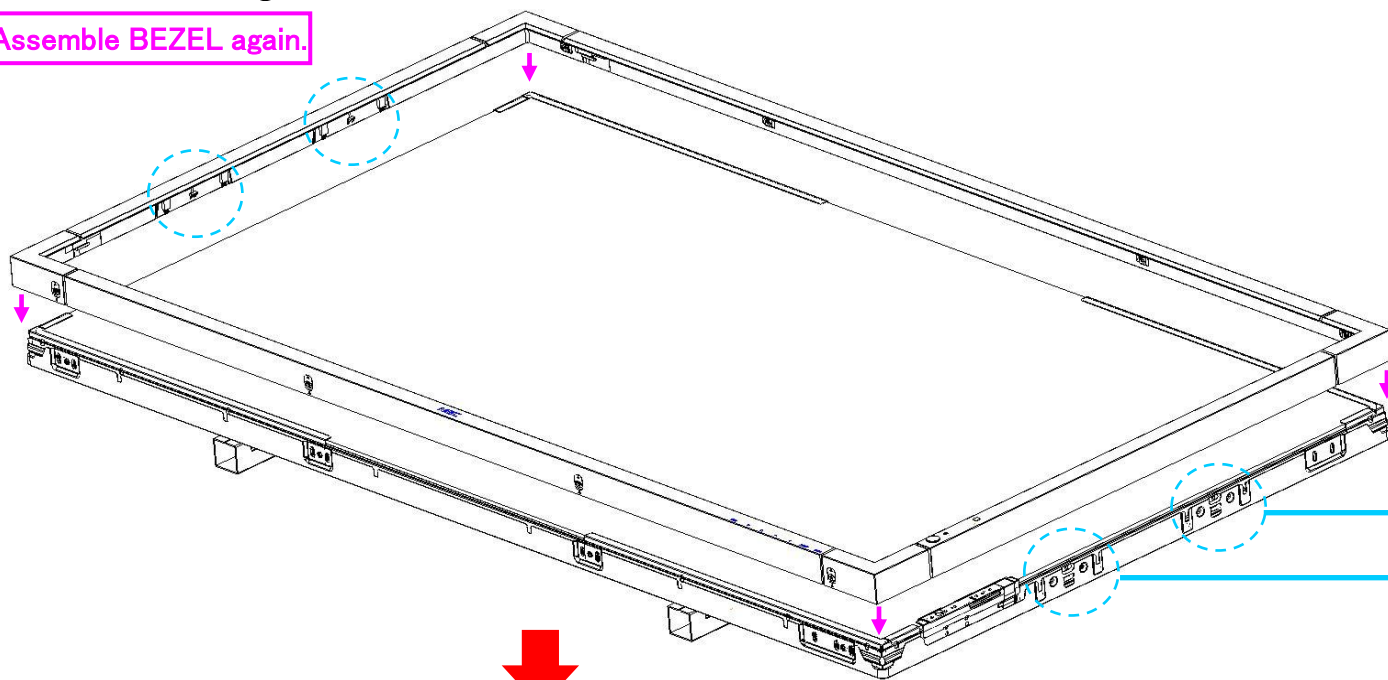

ATTENTION
Check that the hook is catching firmly. (4 places)

Install 8 SCREWS.

FIXING SEQUENCE : 1 → 2

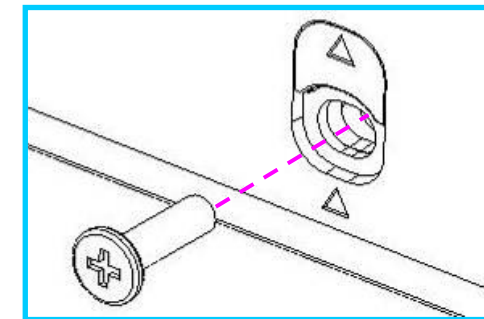
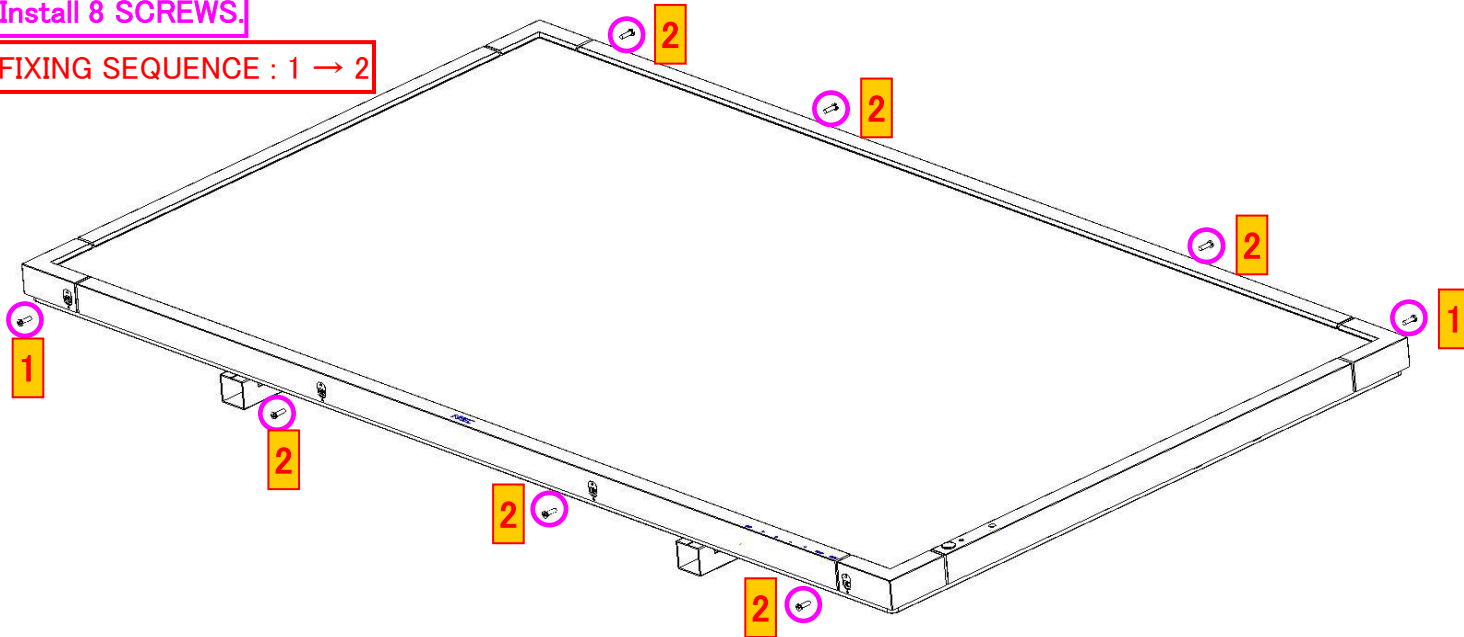

ATTENTION
Fix screw in a specified hole.

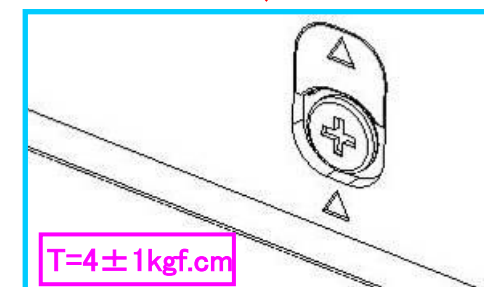

ATTENTION
Fix screw by the specified torque.