



LG

Life's Good

ENGLISH

OWNER'S MANUAL

MONITOR SIGNAGE

Please read this manual carefully before operating the your set and retain it for future reference.

MONITOR SIGNAGE MODELS

47TS50MF

CONTENTS

3 INSTALLATION PREPARATION

- 3 Accessories
- 4 Mounting Holes
- 5 Portrait Layout
- 6 Storage Method for Panel Protection
- 6 - Correct Method
- 6 - Incorrect Method

7 PRODUCT INSTALLATION

- 7 Installing an LVDS Cable
- 8 Lighting Installation
- 9 Installation in Enclosure
- 10 Precaution
- 10 - Correct Method
- 10 - Incorrect Method

11 TROUBLESHOOTING

12 SPECIFICATIONS

14 LVDS PIN MAP GUIDE



NOTE

- The warranty will not cover any damages caused by using the product in an excessively dusty environment.

INSTALLATION PREPARATION

Accessories

Check your product box for the following items. If there are any missing accessories, contact the local dealer where you purchased your product. The illustrations in this manual may differ from the actual product and accessories.



**CD (Owner's Manual)/
Easy Setup Guide**

NOTE

- The accessories supplied with your product may vary depending on the model.
- Product specifications or contents in this manual may be changed without prior notice due to upgrade of product functions.
- LVDS cable is optional and not provided with the product. Please refer to **LVDS Pin Map Guide** on pages 14 to 15 for the LVDS cable assembly.

CAUTION

- Do not use any unapproved or counterfeit parts or accessories to ensure the safety and product life span.
- Any damages or injuries by using unapproved items are not covered by the warranty.

Mounting Holes

Use M3 screws to mount the monitor. There are 20 positions for screws on the rear side of the product.

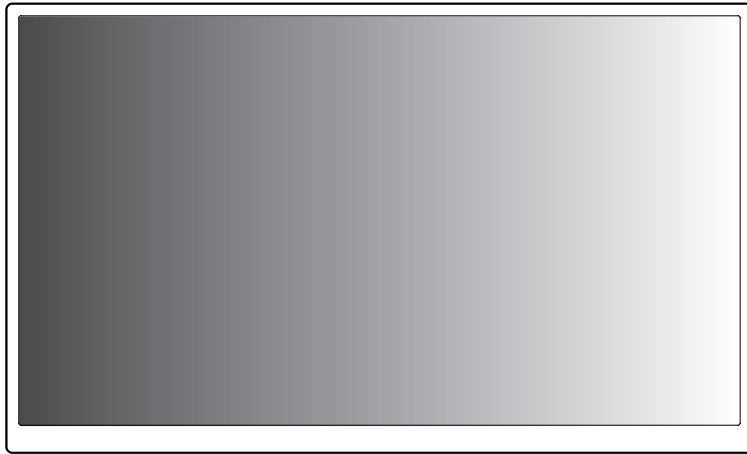

Front of the product

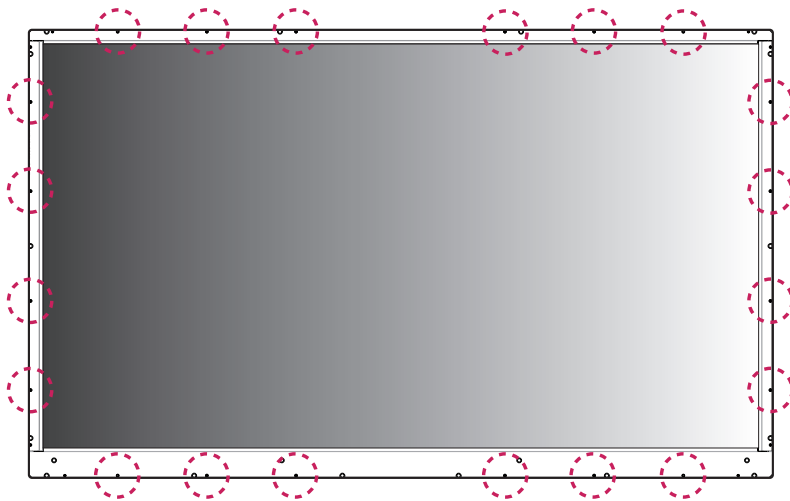

Rear of the product



CAUTION

- This product has the front and back sides. Make sure the product is installed with the front side facing forward.
- Image is displayed reversely on the back side.

Portrait Layout

To install in portrait mode, rotate the set clockwise 90 degrees when looking at from the front. The portrait mode is only available on the scaler board. (The scaler board should support portrait mode.)

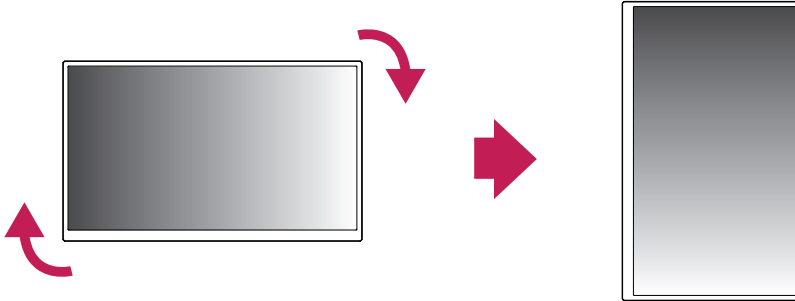

CAUTION

- The scaler board is optional and it is not part of the product.

Storage Method for Panel Protection

Correct Method

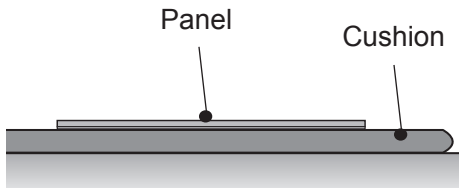

When laying the product on a flat floor, pit it face down on a cushion or blanket to prevent scratching and damage.

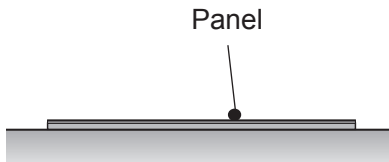

If there is no a cushion or a soft cloth available, ensure the floor is clean. Then lay the product down carefully with the panel facing either upward or downward. At this time, make sure that no object falls on the panel.

Incorrect Method

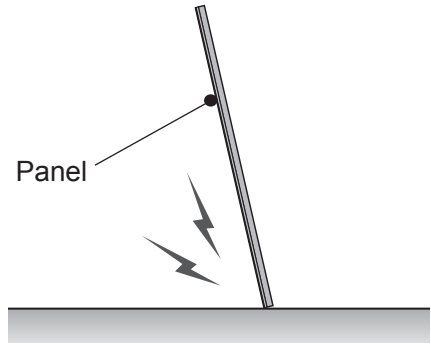

If the product is tilted onto the bezel, the bottom of the panel may be damaged.

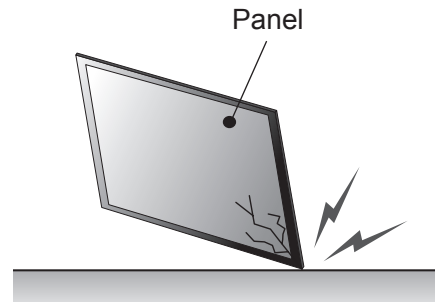

If the product is tilted onto the edge of the panel, the panel may be damaged.

PRODUCT INSTALLATION

Installing an LVDS Cable

The LVDS cable port is located as shown in the figure below.
When installing the product, make sure there is enough space to install the LVDS cable.

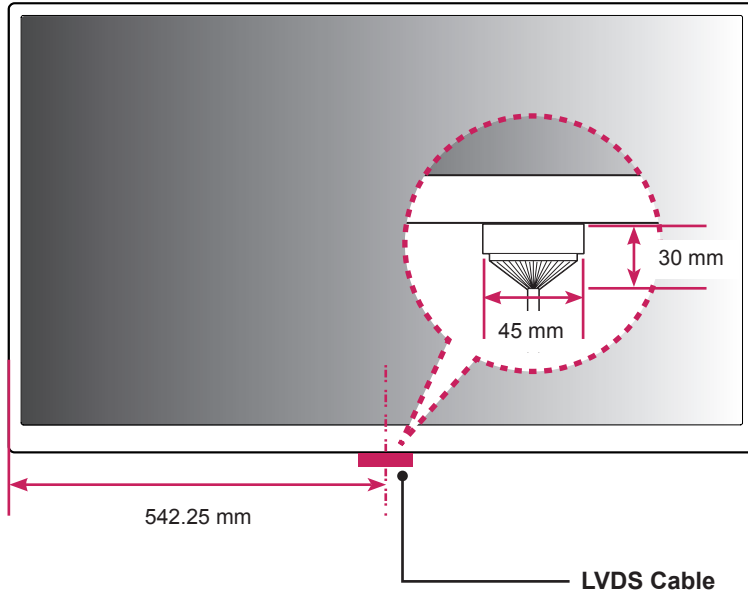

Lighting Installation

This product must be installed with backlighting.

Lighting must be installed behind the product so that the display can be seen clearly.

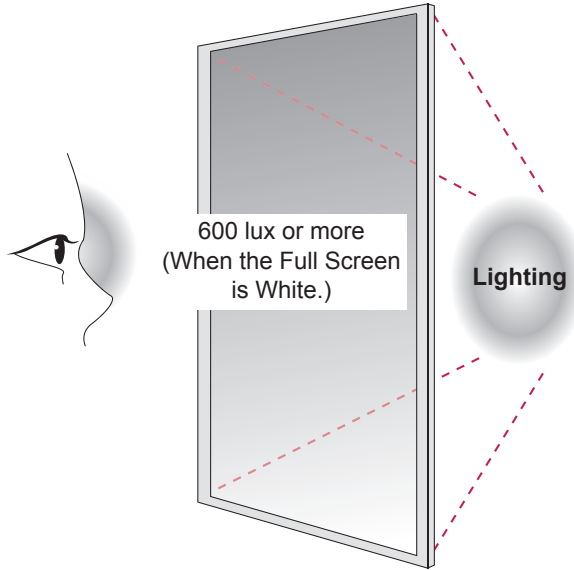

If something obstructs the backlighting, additional lighting may be required.

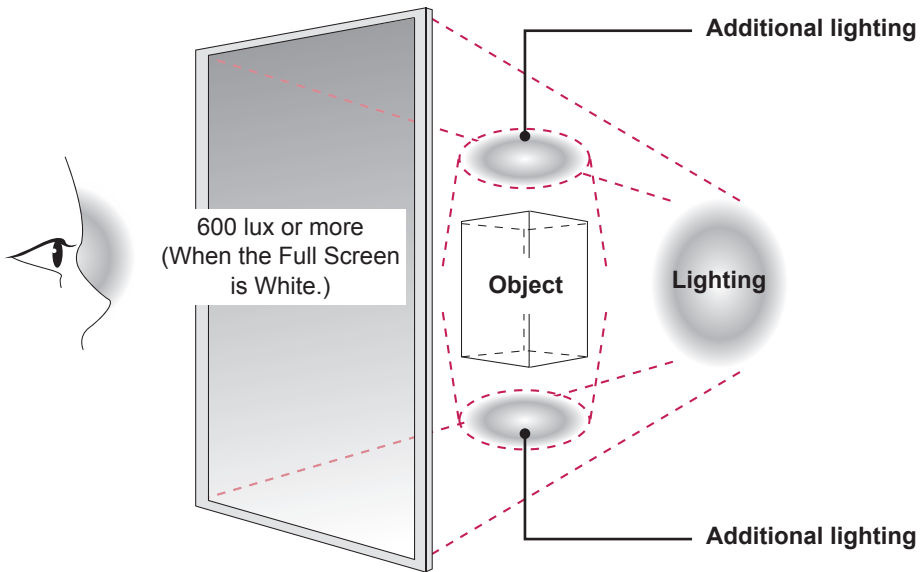

Installation in Enclosure

Install the product in the enclosure. Wear working gloves when installing the product. Do not use bare hands. Otherwise, it may cause personal injury.

- 1 Place the product in the enclosure.
- 2 Attach the product using the prepared screw holes and an additional enclosure guide frame.

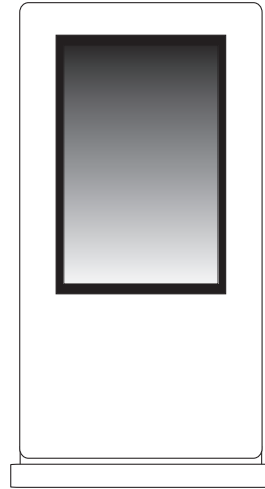
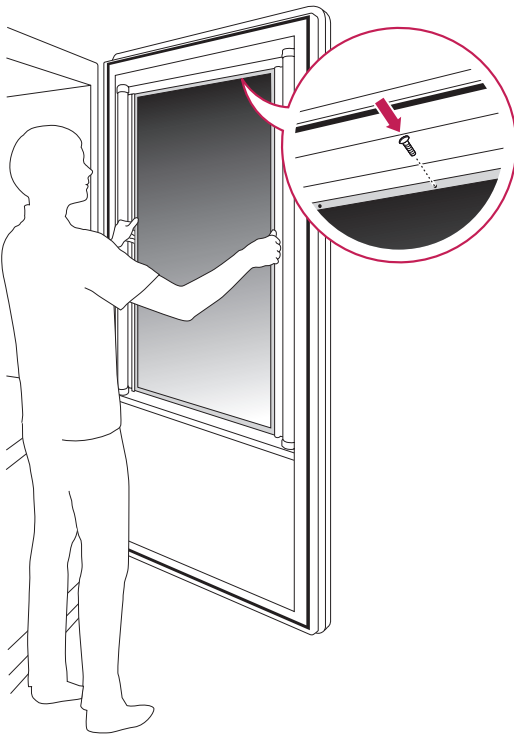

Example of the product in the enclosure

NOTE

- This product can be installed in various locations besides the enclosure.



CAUTION

- The panel of this product is so thin that it can be easily broken when it is exposed to the outside. Use a clear protective cover to keep the product from exposure to the elements.

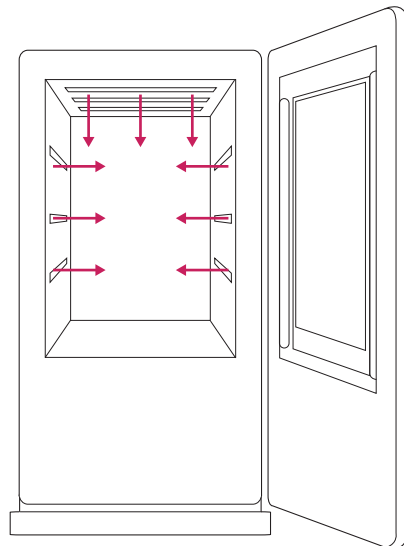

Example of the lighting installation
Lighting must be installed in the enclosure.

Precaution

Correct Method



Do not hold the screen area when holding the product.

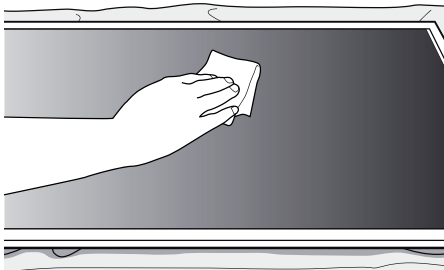

Use a soft cloth moistened with n-hexane to remove dust or stains on the screen.



CAUTION

- If a fixed image displays on the screen for a long period of time, it will be imprinted and become a permanent disfigurement on the screen. This is image burn or burn-in and not covered by the warranty.
- To prevent image sticking, do not play a still image for more than two hours.
- Recommended operation time for optimum performance and reliability is 12 hours or less per day.

Incorrect Method

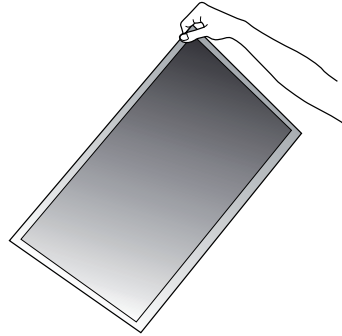

Do not lift up the product by holding a corner.



CAUTION

- Make sure the power is disconnected before moving or installing the product. Otherwise electric shock may occur.
- Wear working gloves when installing the product. Do not use bare hands. Otherwise, it may cause personal injury.
- If you install the product on a ceiling or slanted wall, it may fall and result in severe injury.
- Do not fasten the screws too tightly; this may cause damage to the product and void your warranty.
- Use M3 x 4 mm screws to mount the monitor. Any damages or injuries caused by misuse or use of improper accessories are not covered by the warranty.

TROUBLESHOOTING

After-image appears on the product.

Problem	Resolution
After-image appears when the product is turned off.	<ul style="list-style-type: none"> • If you use a fixed image for a long time, the pixels may be damaged quickly. Use the screen-saver function. • When a dark image is displayed on the screen after an image with high contrast (black and white or gray), this may cause image sticking. This is normal for LCD screen.

Screen color is abnormal.

Problem	Resolution
Screen color is unstable or mono-colored.	<ul style="list-style-type: none"> • Check the connection status of the LVDS cable. • Check whether the LVDS cable is connected correctly following the LVDS Pin Map Guide.
Do black spots appear on the screen?	<ul style="list-style-type: none"> • Several pixels (red, green, white or black color) may appear on the screen, which can be attributable to the unique characteristics of the LCD panel. It is not a malfunction of the LCD.

SPECIFICATIONS

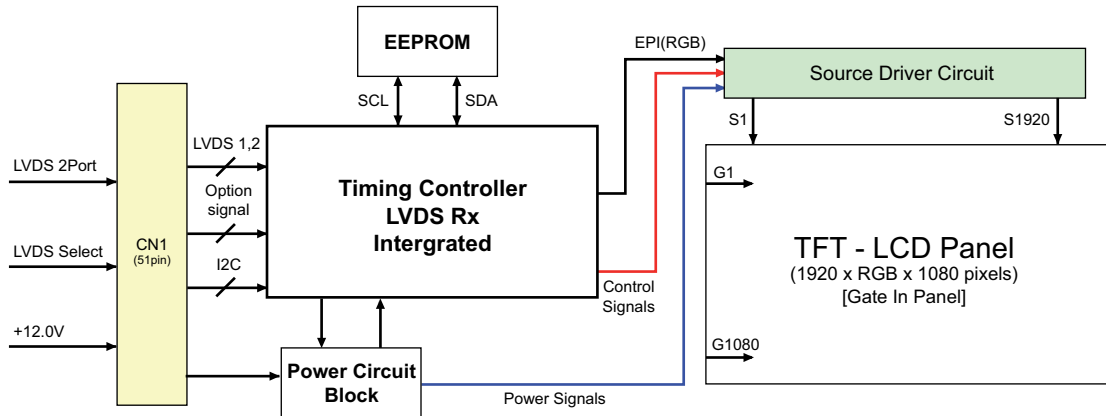

Screen Size	46.96 inch (1192.87mm) diagonal
Dimension (W x H x D)	1084.5 mm x 653 mm x 11.2 mm
Pixel Pitch	0.5415 mm x 0.5415 mm
Pixel Format	1920 horiz. by 1080 vert. Pixels, RGB stripe arrangement
Color Depth	8Bit (D), 16.7 Million colors
Transmittance (With POL)	6.4 % (Typ.)
Viewing Angle (CR>10)	Viewing angle free (R/L 178 (Min.), U/D 178 (Min.))
Power Consumption	Total 6.1 W (Typ.)(TBD)
Weight (head)	2.9 kg
Display Operating Mode	Transmissive mode, Normally black
Surface Treatment (Top)	Hard coating (3H), Anti-glare treatment (Reflectance < 2 %),
Possible Display Type	Landscape and Portrait Enabled

(Unit : mm)

ENGLISH

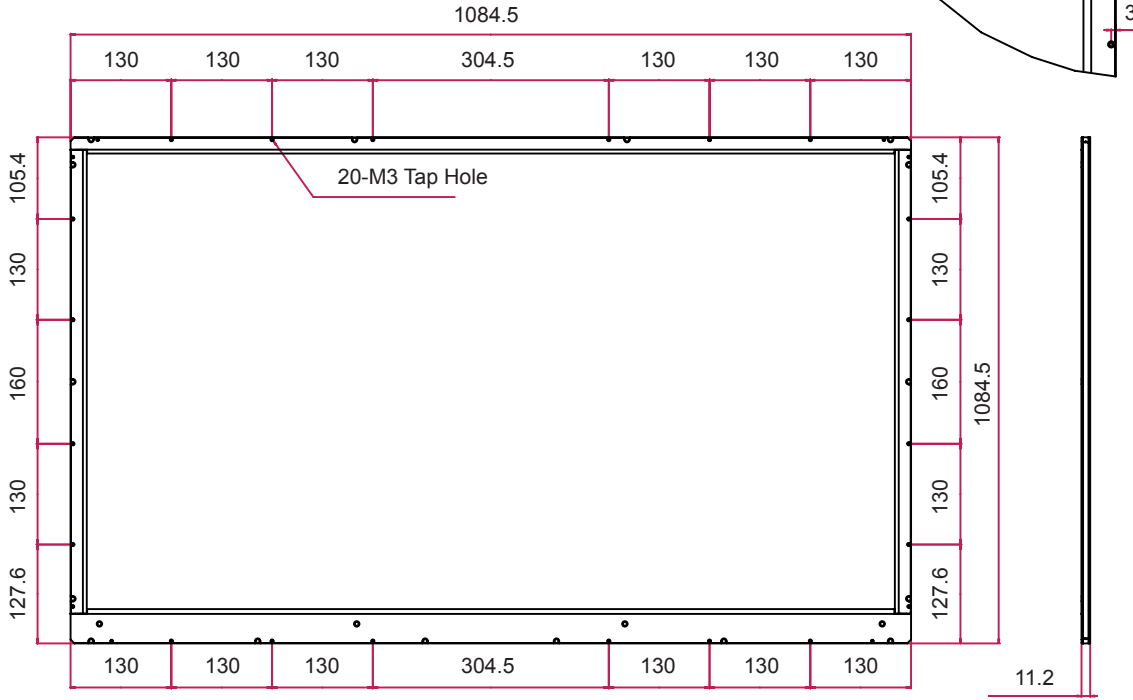

LVDS PIN MAP GUIDE

- LCD Connector(CN1) : FI-RE51S-HF or Equivalent, Refer to below table.
- Mating Connector : FI-RE51HL
- Cable length: 1 m of coaxial cable or less

Pin No.	Symbol	Description	Note
1	NC or GND	No Connection or Ground	
2	NC	No Connection	4
3	NC	No Connection	4
4	NC	No Connection	4
5	NC	No Connection	4
6	NC	No Connection	4
7	LVDS Select	'H' = JEIDA, 'L' = VESA	
8	NC	No Connection	
9	NC	No Connection	
10	NC	No Connection	
11	GND	Ground	1
12	R1AN	FIRST LVDS Receiver Signal(A-)	
13	R1AP	FIRST LVDS Receiver Signal(A+)	
14	R1BN	FIRST LVDS Receiver Signal(B-)	
15	R1BP	FIRST LVDS Receiver Signal(B+)	
16	R1CN	FIRST LVDS Receiver Signal(C-)	
17	R1CP	FIRST LVDS Receiver Signal(C+)	
18	GND	Ground	1
19	R1CLKN	FIRST LVDS Receiver Clock Signal(-)	
20	R1CLKP	FIRST LVDS Receiver Clock Signal(+)	
21	GND	Ground	1
22	R1DN	FIRST LVDS Receiver Signal(D-)	
23	R1DP	FIRST LVDS Receiver Signal(D+)	
24	NC	No Connection	4
25	NC	No Connection	4
26	NC or GND	No Connection or Ground	
27	NC	No Connection	4
28	R2AN	SECOND LVDS Receiver Signal(A-)	
29	R2AP	SECOND LVDS Receiver Signal(A+)	
30	R2BN	SECOND LVDS Receiver Signal(B-)	
31	R2BP	SECOND LVDS Receiver Signal(B+)	
32	R2CN	SECOND LVDS Receiver Signal(C-)	
33	R2CP	SECOND LVDS Receiver Signal(C+)	
34	GND	Ground	1
35	R2CLKN	SECOND LVDS Receiver Clock Signal(-)	
36	R2CLKP	SECOND LVDS Receiver Clock Signal(+)	
37	GND	Ground	1
38	R2DN	SECOND LVDS Receiver Signal(D-)	
39	R2DP	SECOND LVDS Receiver Signal(D+)	
40	NC	No Connection	4

Pin No.	Symbol	Description	Note
41	NC	No Connection	4
42	NC or GND	No Connection or Ground	
43	NC or GND	No Connection or Ground	
44	GND	Ground	5
45	GND	Ground	
46	GND	Ground	
47	NC	No Connection	
48	VLCD	Power Supply+12.0V	2
49	VLCD	Power Supply+12.0V	2
50	VLCD	Power Supply+12.0V	2
51	VLCD	Power Supply+12.0V	2

- Note :
- All GND (ground) pins should be connected together to the LCD module's metal frame.
 - All VLCD (power input) pins should be connected together.
 - All Input levels of LVDS signals are based on the EIA 644 Standard.
 - #1~#6 & #8~#10 NC (No Connection) These pins are used only for LGD (Do not connect)
 - Specific pin No. #44 is used for **No signal detection** of system signal interface.
It should be GND for NSB (No Signal Black) during the system interface signal is not.
If this pin is H, LCD Module displays AGP (Auto Generation Pattern).



Make sure to read the Safety Precautions before using the product.
Keep the Owner's Manual (CD) in an accessible place for future reference.
The model and serial number of the SET is located on the back and one side of the SET.
Record it below should you ever need service.

MODEL _____

SERIAL _____

Temporary noise is normal when powering ON or OFF this device.